

PH Prodont Holliger

LE FABRICANT FRANÇAIS D'INSTRUMENTS ET PRODUITS DENTAIRES

L'Excellence Française à Travers le Monde



www.prodont-holliger.com



Un Savoir-Faire Français...



Conception et usinage par commande numérique.

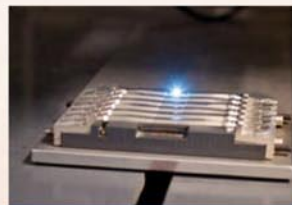

Contrôle Qualité du marquage laser.



Finition et affûtage par contrôle visuel.



Bureau d'études recherche et conception de chalumeaux et brûleurs.



Dernière acquisition en décembre 2013: nouveau tour à commande numérique.



Miroirs: maîtrise de la dépose sous vide du métal sur le verre.



ISO 13485

ISO 9001

Directive 93/42 2007/47 CE

CERTIFICATION ISO

APRAGAZ
Quality Assurance

CEOC

Certificat N°: 13/FR/3250-0-Rev 0

APRAGAZ certifie que le Système Qualité adopté par:

Prodont Holliger
pour les activités suivantes:

Etude, Fabrication, Achats/vente de produits médicaux destinés à l'art dentaire; (miroirs dentaires et laryngiens, disques abrasifs, instruments dentaires, brûleurs, cires dentaires et modèle de démonstration & d'études) Sous-traitances en décolletage

exercées sur le(s) site(s) suivant(s):

Chemin de la Sine, 1156 06140 Vence FRANCE

La Marnasse 63880 Olliergues FRANCE

a été évalué et jugé conforme aux exigences de la norme:

EN - ISO 13485 (2012)

A l'exclusion des § 7.5.1.2 1 a) b) 4 c), 7.5.1.2.2.4.3, 7.5.1.3, 7.5.3.2.2 et 8.2.4.2

Date de Certification originale: 31/10/2013

Sous réserve du fonctionnement continu et satisfaisant du système qualité de l'entreprise, ce certificat est valable pour une période de trois ans jusqu'au:

01/12/2016

Date d'émission: 02/12/2013

Le Directeur Général: *[Signature]*

Le représentant de l'entreprise: *[Signature]*

Ch. Lepiet, Sr. P10091-003

APRAGAZ
Quality Assurance

CEOC

Certificat N°: 13/FR/3249-0-Rev 0

APRAGAZ certifie que le Système Qualité adopté par:

Prodont Holliger
pour les activités suivantes:

Etude, Fabrication, Achats/vente de produits médicaux destinés à l'art dentaire; (miroirs dentaires et laryngiens, disques abrasifs, instruments dentaires, brûleurs, cires dentaires et modèle de démonstration & d'études) Sous-traitances en décolletage

exercées sur le(s) site(s) suivant(s):

Chemin de la Sine, 1156 06140 Vence FRANCE

La Marnasse 63880 Olliergues FRANCE

a été évalué et jugé conforme aux exigences de la norme:

EN - ISO 9001 (2008)

Date de Certification originale: 31/10/2013

Sous réserve du fonctionnement continu et satisfaisant du système qualité de l'entreprise, ce certificat est valable pour une période de trois ans jusqu'au:

01/12/2016

Date d'émission: 02/12/2013

Le Directeur Général: *[Signature]*

Le représentant de l'entreprise: *[Signature]*

Ch. Lepiet, Sr. P10091-002

APRAGAZ
Quality Assurance

CEOC

Certificat N°: 08/FR/1513-1-REV 0

Page 1/2

CERTIFICAT CE DE CONFORMITE
En accord avec l'Annexe V de la Directive 93/42/CE et son amendement 2007/47 relatifs aux Dispositifs Médicaux

Fabricant	Nom	PRODONT HOLLIGER
	Adresse	Chemin de la Sine, 1156 FR - 06140 VENCE FRANCE Lieu-dit La Marnasse 63880 OLLIERGUES FRANCE

Champ d'application:
Dispositifs médicaux avec fonction de mesure repris dans la liste établie par Prodont Holliger (FCH DMFM 01), voir page 2/3 et 3/3 du présent certificat.

Le présent document certifie que le système de management de la qualité du fabricant mentionné ci-dessus a été vérifié suivant les exigences de l'Annexe V de la Directive relative aux dispositifs médicaux 93/42/CE et est conforme aux exigences essentielles de sécurité pour les équipements indiqués ci-dessus.

L'approbation est conditionnée par le maintien du système en accord avec les exigences de la Directive susmentionnée. Celui-ci sera contrôlé par des audits intermédiaires, des inspections et surveillances.

Le fabricant est autorisé à apposer le marquage "CE" suivi de notre numéro d'identification d'organisme notifié 0029, sur les équipements approuvés suivant les conditions décrites dans la Directive.

L'approbation est valable jusqu'au 01/12/2016

Dev: 02/12/2013	Nom: Ch. Lepiet	Position: Directeur Général
N° d'identification Organisme Notifié: 0029	Signature: <i>[Signature]</i>	

Cachet Organisme Notifié: **APRAGAZ**
Belgium
Inspecting
Authority

Reference Organisme Notifié: P10091-001
Date de certification originale: 06/10/2008

RP220 rev 0

Un peu d'Histoire...

History in the making...

1927

Création de la société **HOLLIGER** à Audincourt (Doubs) par M. Holliger, prothésiste, et sa femme, chirurgien dentiste.

Creation of the HOLLIGER company in Audincourt (Doubs, France) by Mr. Holliger and his wife, a dentist.



1948

En Auvergne, M. Dubost crée sa gamme d'instruments. Spécialisé dans la fabrication de couteaux, il veut répondre à la demande des chirurgiens dentistes.

In Auvergne (center of France), Mr. Dubost creates a dental instrument range. Specialized in knife making, he wants to meet the dentists demands.

1960

Après le décès de M. Dubost, M. Maréchal, directeur technique, dirige la société et crée la marque d'instruments dentaires **SAFICO®**.

At Mr. Dubost death, Mr Marechal, former technical manager, takes charge of the company and creates the SAFICO® brand of dental instruments.

1975

Bernard Holliger développe sa marque de miroirs dentaires **ACTUAL®**.

Bernard Holliger develops his dental mirror brand ACTUAL®.

1975

En Normandie, création de la marque **MINIFLAM®** par un prothésiste (mini chalumeaux) et des modèles de démonstration.

In Normandie, creation of the MINIFLAM® brand (small burners) and demonstration models.

1980

Acquisition de la société **PRODONT®**, fabricant des disques abrasifs **SPEEDY®** et des cires dentaires **ESVE®**.

The PRODONT company, manufacturer of SPEEDY® abrasive discs and ESVE® waxes, is acquired.



1986

PRODONT-HOLLIGER devient partie intégrante du groupe industriel NEW GROUPE NADIA, situé à Cholet.

PRODONT-HOLLIGER becomes part of NEW NADIA GROUP industrial Group, in Cholet (France).



Cabinet



PURE REFLECT	page 4
Décolleur de ROOS / Elevator	page 8
Bistouri Bard-Parker / Scapel	page 66
Instruments Implantologie / Implantology instr.	page 79
HOLLINOX	page 92
Gamme Zirconie / Zirconia range	page 107
Cube Cristal / Crystal cubes	page 139

CABINET DENTAIRE *Dental practice*

MIROIRS et DIAGNOSTIC
Mirrors / Mundspiegel / Espejos
page 4

RESTAURATION
Restorative / Restauracion
page 18

PARODONTOLOGIE
Periodontal / Periodoncia
page 34

EXTRACTION
Extraktion / Extraccion
page 44

CHIRURGIE
Surgery / Cirugia
page 58

IMPLANTOLOGIE
Implantology / Implantologia
page 67

ORTHODONTIE
Orthodontia / Ortodoncia
page 82

ACCESSOIRES
Accessories / Verschiedenes Zubehör / Accesorios
page 91



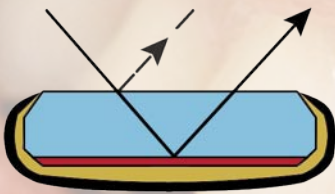
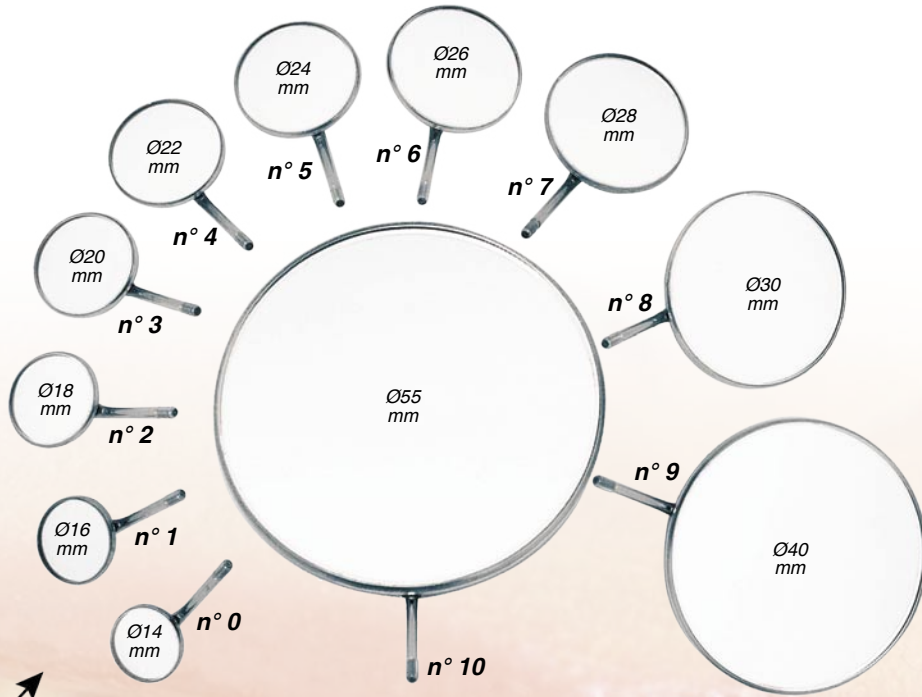

ALUMINIUM Back Surface

Métal déposé **SOUS** le verre dit «Back surface»
Reflecting surface **UNDER** the glass

Nos 3 catégories de miroirs Front Surface:
Our 3 types of Font Surface Mirrors

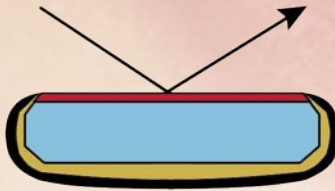

Métal déposé **SUR** le verre dit «Front surface»
Reflecting surface **ON** the glass

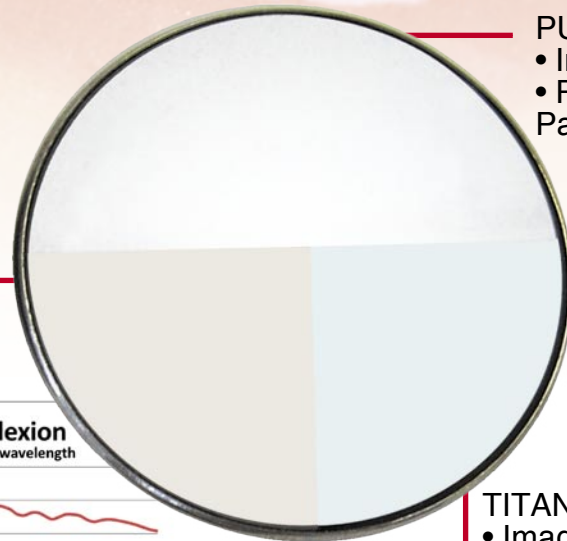

RHODIUM

- Résistant aux rayures
Chirurgie, implantologie
- *Scratch resistant*
Surgery, implantology

PURE REFLECT

- Image très claire
 - Résistant
- Parfait dans tous les domaines

NOUVEAUTÉ
NEW

- *Very bright image*
- *Resistant*
All purpose perfection

TITANIUM

- Image claire
Parodontologie
- *Bright image*
Periodontics

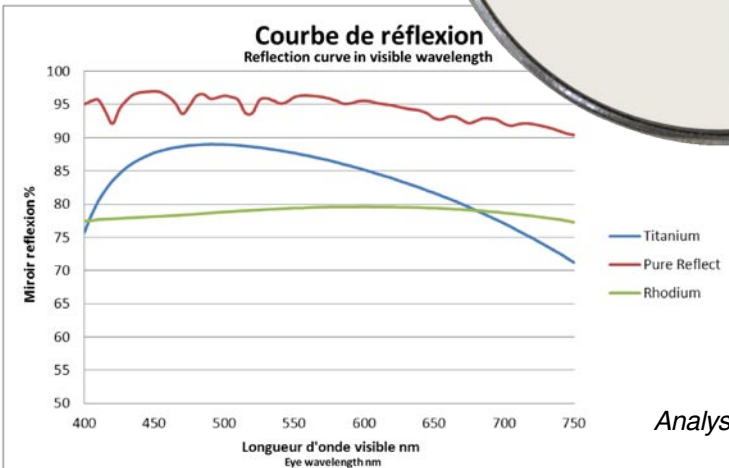

Analyse: Laboratoire Hubert Curien CNRS France 12/2013

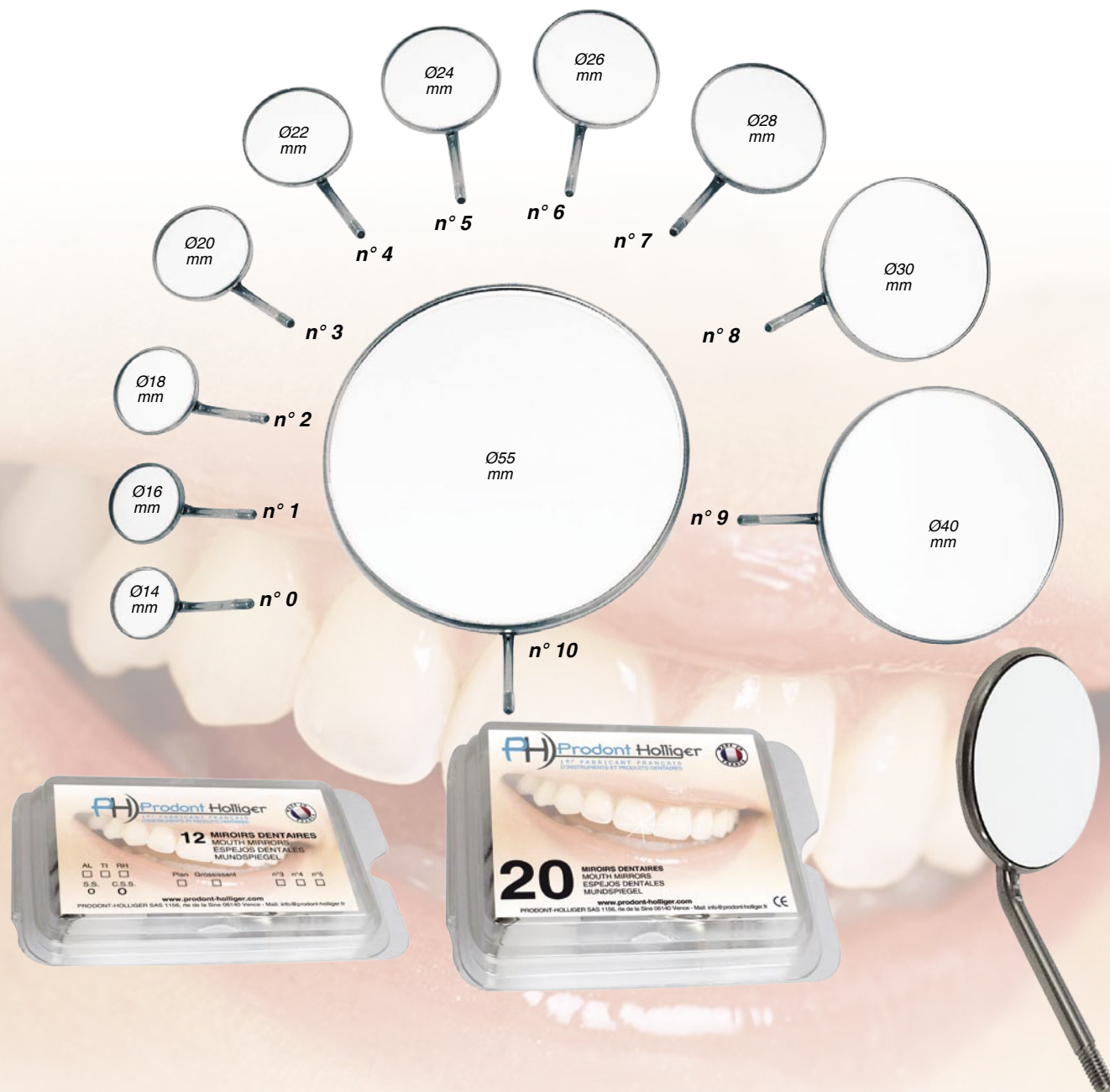

PURE REFLECT®

ALUMINIUM

RHODIUM

TITANIUM

	PURE REFLECT®				ALUMINIUM				RHODIUM				TITANIUM			
	N°	Ref.	Qtt	€HT	N°	Ref.	Qtt	€HT	N°	Ref.	Qtt	€HT	N°	Ref.	Qtt	€HT
Plan	4	3622	12	41,58	2	3118	12	27,05	2	3318	12	40,74	3	3520	12	36,39
	5	3624	12	41,58	3	3120	12	21,75	3	3320	12	40,74	4	3522	12	29,71
					4	3122	12	15,28	4	3322	12	33,21	5	3524	12	29,71
					5	3124	12	15,28	5	3324	12	33,21	6	3526	12	35,43
					6	3126	12	23,55	6	3326	12	39,78	7	3528	1	4,35
					7	3128	1	4,24	7	3328	1	4,67	8	3530	1	4,99
					8	3130	1	4,24	8	3330	1	5,30	9	3540	1	7,96
					9	3140	1	5,30	9	3340	1	8,59	10	3555	1	13,79
					10	3155	1	7,53	10	3355	1	14,96				
	Grossissant x3,5					2	3218	12	32,25	4	3422	12	53,89			
					3	3220	12	32,25	5	3424	12	53,89				
					4	3222	12	19,94								
					5	3224	12	20,69								
					6	3226	12	37,56								
					7	3228	1	5,30								
					8	3230	1	6,90								
					9	3240	1	8,06								
					10	3255	1	11,78								

Plan par boîte de 20

N°	Ref.	Qtt	€HT	N°	Ref.	Qtt	€HT
4	MPV3122	20	23,07	4	MPV3322	20	49,85
5	MPV3124	20	23,07	5	MPV3324	20	49,85

MIROIRS GRADUÉS

Millimetric mirrors - Graduierte Spiegel - Espejos graduados

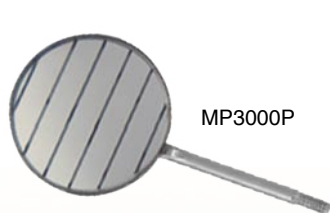

MP3000P



Miroir du Dr Bensadoun
Double face 5x3cm, grad. 8mm



MP5000P

Ref. €HT
MP3000P 11,35

Ref. €HT
MP5000P 32,25

DIAGNOSTIC

Miroirs de bouche
Mouth mirrors - Mundspiegel - Espejos de boca

MONTURE PLASTIQUE

Fibre glass mirrors - Mundspiegel aus Fiberglas - Espejos de plástico



ALUMINIUM

mm	N°	Ref.	Qtt	€HT
22	4	9122	12	19,94

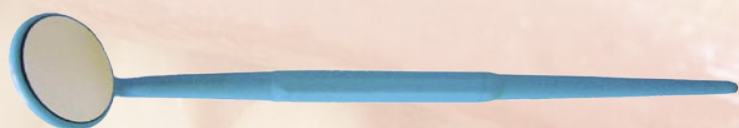

RHODIUM

mm	N°	Ref.	Qtt	€HT
22	4	9322	12	31,08

CANULES D'ASPIRATION + MIROIRS

Suction cannulas - Absaugkanüle - Cánulas de aspiracion



161.MIX

2 Canules d'aspiration avec miroir

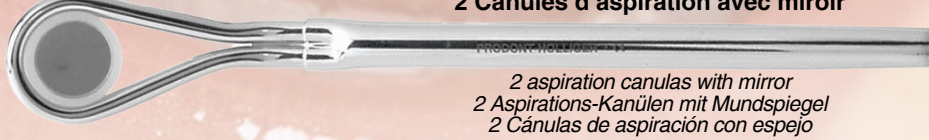

2 aspiration canulas with mirror
2 Aspirations-Kanülen mit Mundspiegel
2 Cánulas de aspiración con espejo

Jusqu'à épuisement des stocks
Until the end of stocks / So langer der Vorrat reicht / Hasta el final del existencia

160.PMI

5 pastilles miroir pour canule



5 plastic discs with mirror for canula
5 Plastscheiben für Aspirationskanüle
5 pastillas de plastico con espejo

Ref.	€HT
161.MIX	74,25
160.PMI	26,65

SOLUTION ANTI GOUTTES

Anti-Mist protection for mirrors - Anti Dunst für Spiegel - Solucion Antivaho para espejos

Une efficacité incomparable



1. Pulvérisiez
2. Essuyez
3. Prêt à l'emploi

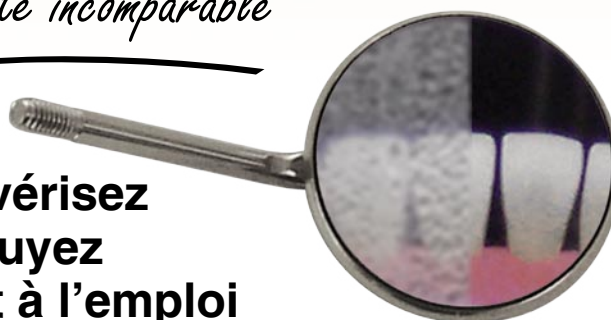

Ref. €HT
AB 17,00

*Pulverise
Wipe
Ready to use*

*Pulverisieren
Wischen
Anwendungsbereit*

*Pulverice
Seque
Preparado al empleo*

MIROIRS DOUBLE FACE
Double sided - Doppelseitig - Doble cara

Grâce aux 2 faces réfléchissantes opposées, plus besoin de tourner le miroir pour passer de droite à gauche en bouche.
Monture adaptée à la cavité buccale

Double sided mirror, Ergonomic mounting: no need to turn the mirror



DIAGNOSTIC
Miroirs de bouche
Mouth mirrors - Mundspiegel - Espejos de boca

RHODIUM

mm	N°	Ref.	Qtt	€HT
22	4	7322	12	96,75
24	5	7324	12	96,75
22	4	7422	6	51,45
24	5	7424	6	51,45

TITANIUM

mm	N°	Ref.	Qtt	€HT
22	4	7522	12	85,51
24	5	7524	12	85,51
22	4	7622	6	45,51
24	5	7624	6	45,51

GAMME DELUXE

Top range - Hohe Qualität - Gran calidad



Emballage individuel = Transport sécurisé

*individually packed and protected
 Individuelle Packung
 Cajitas individuales*



**Boîte Plexiglass
 Protections individuelles**

*Plexiglas box with individual slots
 Plexiglas Pckg
 Caja de plexiglas*



Traitement Anti-buée

Anti Mist - Hauchfrei - Antivahos



**ALUMINIUM
 HOLY**

	mm	N°	Ref.	Qtt	€HT
Plan	22	4	105122	12	57,61
	24	5	105124	12	57,61

**ALUMINIUM
 HOLY CLAR**

	N°	Ref	Qtt	€HT
Plan	4	105222	12	66,73
	5	105224	12	66,73

**ALUMINIUM
 DMS**

	N°	Ref	Qtt	€HT
Plan	4	103122	12	41,91
	5	103124	12	41,91

**RHODIUM
 DMS**

	N°	Ref.	Qtt	€HT
Plan	4	103322	12	60,79
	5	103324	12	60,79

**Grossissant
 x3,5**

	N°	Ref.	Qtt	€HT
Grossissant x3,5	4	105322	12	60,26
	5	105324	12	60,26

	N°	Ref	Qtt	€HT
Grossissant x3,5	4	105422	12	67,26
	5	105424	12	67,26

	N°	Ref	Qtt	€HT
Grossissant x3,5	4	103222	12	60,79
	5	103224	12	60,79

	N°	Ref.	Qtt	€HT
Grossissant x3,5	4	103422	12	67,79
	5	103424	12	67,79

NOUVEAUTÉ
NEW

DECOLLEUR DU Dr ROOS

Dr ROOS RETRACTOR

DIAGNOSTIC

3 en 1

Tous les avantages d'un décolleur,
d'un écarteur et de la vision d'un
excellent miroir!

UTILISATION

- Décoller les tissus mous.
- Rétracter et écarter avec appui osseux.
- Grâce au miroir intégré, contrôle visuel de l'acte chirurgical **pendant sa réalisation.**



manche
XL Style
handle



Mise en place d'implant avec contrôle de l'axe, forage et vissage.

Setting of implant with control of the axis while drilling and screwing.

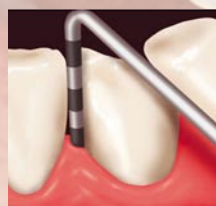

Contrôle de l'élimination du tartre et des défauts osseux dans le miroir.

Control of the elimination of the tartar and the osseous defects in the mirror.



Contrôle de la résection apicale (opération d'un abcès sur l'extrémité de la racine de la dent) lors de chaque phase:

décollement de la gencive, forage de l'os, section de la pointe de la racine, curetage de la cuvette osseuse, préparation et obturation du canal.

Control of the apical resection (removal of an abscess on the tip of the root) during every phase: Retraction of the gum, drilling of the bone, the section of the tip of the root, curettage of the osseous basin, the preparation and the closing of the canal.

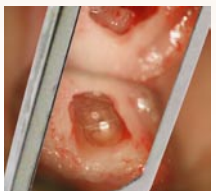

Photographie sous microscope ou à vue indirecte

Permet d'augmenter la profondeur de champ.

*Photography under microscope or at indirect sight
Increases depth of field.*



Ref. €HT
407.05XL 138,54

MICRO MIROIRS

Micro mirrors

DIAGNOSTIC

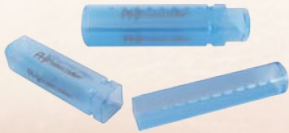

NOUVEAU PACKAGING



Pas de vis standard sur manche au choix / To screw on standard handle

Opérations avec loupe ou microscope : Nos Micro-miroirs répondent à vos exigences !

PURE REFLECT®: réflexion haute définition.

Designed for surgery under microscope and magnifying glass.

PURE REFLECT®: High definition reflection

Ref.	€HT
3303	58,24
3305	58,24
3306R	69,91
3310R	69,91



Ref.	€HT
1303	58,24
1305	58,24
1306R	69,91
1310R	69,91

MIROIRS LARYNGIENS

Laryngeal mirrors - Kehlkopfspiegel - Espejos laríngeos



ALUMINIUM				RHODIUM			
mm	N°	Ref.	€HT	mm	N°	Ref.	€HT
10	000	2110	4,88	10	000	2310	6,58
12	00	2112	4,88	12	00	2312	6,58
14	0	2114	4,88	14	0	2314	6,58
16	1	2116	4,88	16	1	2316	6,58
18	2	2118	4,88	18	2	2318	6,58
20	3	2120	4,88	20	3	2320	6,58
22	4	2122	4,88	22	4	2322	6,58
24	5	2124	4,88	24	5	2324	6,58
26	6	2126	4,88	26	6	2326	6,58
28	7	2128	4,88	28	7	2328	6,58
30	8	2130	4,88	30	8	2330	6,58
Tige Fileté				Tige Lisse			
10	000	1110	4,67	10	000	1310	6,37
12	00	1112	4,67	12	00	1312	6,37
14	0	1114	4,67	14	0	1314	6,37
16	1	1116	4,67	16	1	1316	6,37
18	2	1118	4,67	18	2	1318	6,37
20	3	1120	4,67	20	3	1320	6,37
22	4	1122	4,67	22	4	1322	6,37
24	5	1124	4,67	24	5	1324	6,37
26	6	1126	4,67	26	6	1326	6,37
28	7	1128	4,67	28	7	1328	6,37
30	8	1130	4,67	30	8	1330	6,37

Longueur de la tige: 140mm

Manche orientable pour miroirs photographiques

Photographic mirrors holder - Halter für Fotospiegel - Mango para Espejos fotográficos

DIAGNOSTIC



L. 148 mm, diam. 15mm à 20mm, 107g, Rot. 70°

Aluminium anodisé, forme légèrement conique. L'extrémité mobile permet de photographier sous différentes inclinaisons sans toucher le miroir.

Les 2 faces du miroir double sont utilisables. Notre manche peut recevoir tous nos miroirs photographiques, interchangeables en un clin d'oeil.



Ecarteurs

Cheek retractors - Wangenhalter - Separadores

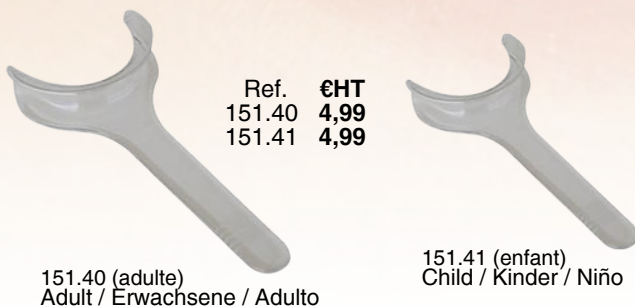

Ref.	€HT
151.40	4,99
151.41	4,99

151.40 (adulte)
Adult / Erwachsene / Adulto

151.41 (enfant)
Child / Kinder / Niño



Le manche MZP214 58,99€ HT



Anodized aluminium, slightly cone shaped. The articulated upper part permits taking photos in different positions without touching the mirror. Both sides of our double sided photographic mirrors can be used for an extra long life time. Our new handle can hold all types and shapes of our photographic mirrors in an instant.



Konische Form, anodisiertes Aluminium. Einstellbares Kopfteil, das die Foto-Aufnahme in verschiedenen Einstellungen erlaubt, ohne den Spiegel zu berühren. Beide Seiten unserer doppelseitigen Fotospiegel können benutzt werden. Alle unserer Fotospiegel können in unseren Griff eingefügt werden.



De aluminio anodizado y de forma ligeramente cónica. La parte superior orientable permite sacar fotografías en diferentes inclinaciones sin tocar el espejo. Con los espejos de doble cara ambas son utilizables. Nuestro mango sirve para todos nuestros espejos fotográficos.

Miroirs photographiques

Photographic mirrors - Fotospiegel - Espejos fotográficos

DIAGNOSTIC



Face occlusale Adulte
Occlusal surfaces Adult

Titanium Ref. MZP511
Chrome Ref. MZP512



Face occlusale Enfant
Occlusal surfaces Child

Titanium Ref. MZP521
Chrome Ref. MZP522



Faces Vestibulaires
Buccal surfaces

Titanium Ref. MZP531
Chrome Ref. MZP532

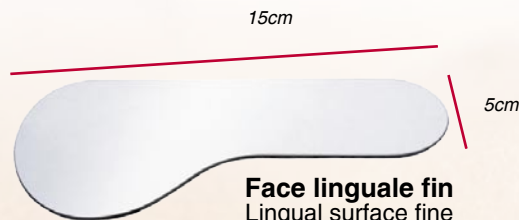

Face linguale fin
Lingual surface fine

Titanium Ref. MZP541
Chrome Ref. MZP542



Face linguale large
Lingual surface wide

Titanium Ref. MZP551
Chrome Ref. MZP552



Forme latérale
lateral shape

Titanium Ref. MZP561
Chrome Ref. MZP562

Titanium 63,45 €HT
Chrome 45,01 €HT

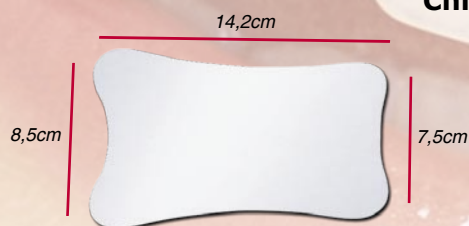

Titanium Ref. MZP581
Chrome Ref. MZP582



Titanium Ref. MZP571
Chrome Ref. MZP572

Courbe de réflexion dans le spectre visible

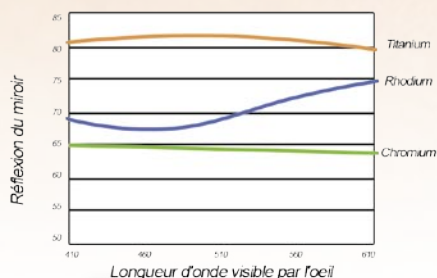

Les miroirs PRODONT-HOLLIGER sont utilisés pour la photographie intra-buccale. Leur revêtement haute-technologie se décline en deux versions: titanium et chrome.

Le **titanium** assure une netteté incomparable de l'image, une plus grande clarté ainsi qu'une meilleure résistance à l'abrasion. Le **chrome** représente une alternative économique au titanium tout en restant fidèle aux critères de qualité de PRODONT-HOLLIGER.

Les miroirs bi-faces sont réversibles et résistants aux stérilisations répétées par vapeur et autoclave.



Photographic mirrors are used for intra-oral photography.

PRODONT-HOLLIGER photographic mirrors are available in two versions: High-Tech Front Surface coating with either Chromium or Titanium.

Titanium offers a definition of the reflected image incomparable in brightness, sharpness and clarity.

The Chromium version presents an economical alternative in the usual PRODONT-HOLLIGER quality.

Our photographic mirrors are resistant to repeated sterilizations in an autoclave.



PRODONT-HOLLIGER Spiegel werden von Zahnärzten und Orthopäden weltweit benutzt. Unsere Spiegel eignen sich für Aufnahmen innerhalb des Mundraumes, um ein klares und scharfes Abbild mit Digitalkameras zu gewährleisten. Unsere Fotospiegel sind mit Titanium oder Chrom beschichtet.

Titanium ist ein dauerhaftes und langlebiges Metall, welches gegenüber den verchromten Alternativen ein besseres Abbild in unvergleichlicher Schärfe und Klarheit widerspiegelt. Alle Spiegel sind beidseitig beschichtet und widerstandsfähig bei wiederholter Dampfsterilisation und Autoklav.



La alta tecnología de su recubrimiento se ofrece en dos versiones: titanio y cromo.

El **titanio** garantiza una nitidez incomparable de la imagen, una mayor transparencia y una mejor resistencia a la sobre exposición.

El **cromo** representa una alternativa económica al titanio, al mismo tiempo que satisface los criterios de calidad de Prodont-Holliger. Los espejos de doble cara son reversibles y resistentes a las esterilizaciones repetidas, por vapor y autoclave.

LE SYNDROME DU CANAL CARPIEN

THE CARPAL TUNNEL SYNDROM

LES SYMPTOMES

Picotements dans le pouce, l'index, le majeur et l'annulaire
Douleurs nocturnes pouvant s'étendre au bras et à l'épaule
Engourdissement, perte de dextérité et de force
Peau de la main sèche

*Tingling in thumb, forefinger, middle finger and ring finger
Night-time ache that can reach arm and shoulder
Numbness, loss of strength and agility
Dry hands*

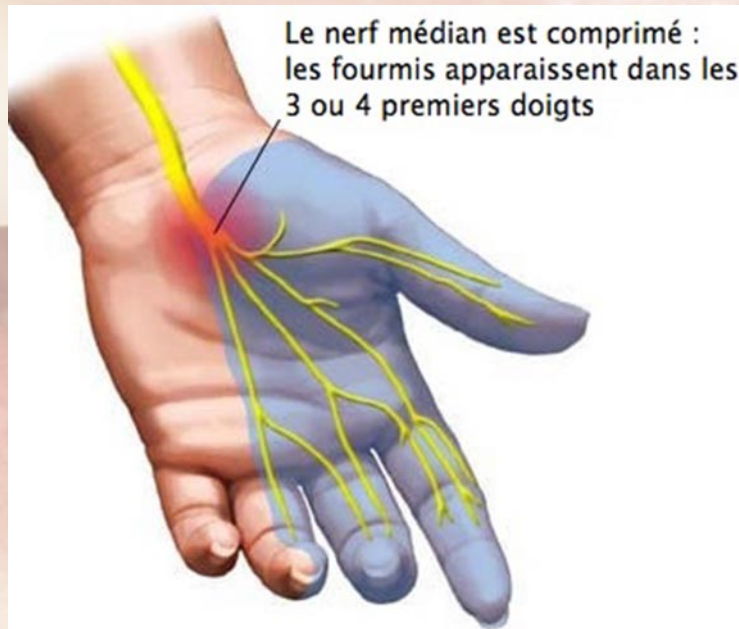

PREVENTION AU QUOTIDIEN

Augmentation du diamètre des instruments utilisés
afin de réduire la pression des doigts.

*Increase of instruments' diameter
in order to reduce the pressure exerted by the fingers.*

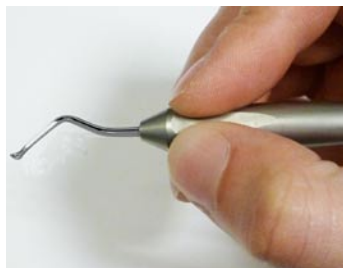

La première gamme professionnelle depuis 2009

The first Professional Instrument Range since 2009

XL Style

DIAGNOSTIC

Augmentation du diamètre des instruments:

précision du geste chirurgical
prévention du syndrome du canal carpien

*Increase of instruments' diameter:
precise gesture
prevention of carpal tunnel syndrome*



Manche creux en Inox Médical:

faible poids
résistance à la corrosion.

*Hollow handle made of medical grade Stainless Steel:
light weight
corrosion resistant*

Zone de repos « appui-doigt »:
confort d'utilisation au long cours.

*Rest-zone for fingers:
long-term ease of use*



Manche parfaitement lisse:
pas de rétention de sang ou autre
hygiène parfaite
nettoyage simplifié

*Smooth surface:
no blood retention
perfect cleanliness*



Manche satiné:
repos visuel: pas de réflexion
de la lumière du scialytique
effet grip léger: ne glisse pas

*Satin-like aspect:
Eye-friendly: no reflection of
scyalitic light on the handle
Better grip*



Manche Satiné / satin-like



Manche Brillant / bright

MANCHES MIROIRS
 Mouth mirrors handles - Mundspiegel-Griffe - Mangos para espejos

DIAGNOSTIC

Manches pour miroirs
 Mouth mirrors handles - Mundspiegel-Griffe - Mangos para espejos



210.00XL *manche XL Style handle*



210.00D *manche Design handle*

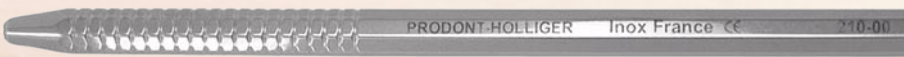

210.00

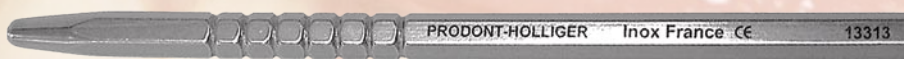

13313 Hexagonal



210.01 Gradu  / millimetric / graduierete / graduado



■ 218.00 **Jusqu'   puisement des stocks**
Until the end of stocks / So langer der Vorrat reicht / Hasta el final del existencia

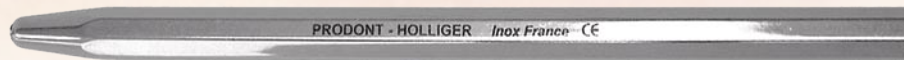

219.00 Octogonal 7mm



43815 Fibre de verre /Fiberglas /Fiberglas /fibra de vidrio

Ref.	� HT
13313	3,50
15231	3,18
210.00	3,90
210.01	19,95
212.00	6,37
216.00	8,91
218.00	7,85
219.00	4,46
43815	3,71
210.00D	5,30
212.00D	5,30
210.00XL	9,76
212.00XL	12,52

MANCHES pour MIROIRS LARYNGIENS
 Laryngeal mirror handle - Griff f r Kehlkopfspiegel - Mango, Espejos lar ngeos



15231



216.00



KITS EXAMEN & SOIN

Examination & Care Sets - Diagnostik & Pflege Sets - Equipos cuidado y examen

Kit Examen 3 instruments

Examination Set - Prüfungs-Set
Set de Examen



manche
XL Style
handle

500.00XL **40,63€ HT**

Kit Examen

- 1 manche (210.00XL / D) avec miroir à bouche P4 (3122)
- 1 sonde simple design (262.20XL / D)
- 1 précelle Collège (220.02)

Kit Soins 4 instruments

Care Set - Pflege Set
Set de Cuidado



manche
XL Style
handle

501.00XL **58,14€ HT**

Kit Soins

- 1 manche (210.00XL / D) avec miroir à bouche P4 (3122)
- 1 spatule Heidemann H.E.I. n°1 pour obturation et modelage (193.01XL / D)
- 1 sonde n°9 (262.09XL / D)
- 1 précelle Collège (220.02)



manche
Design
handle

500.00D **31,30€ HT**



manche
Design
handle

501.00D **41,27€ HT**

DIAGNOSTIC

Kits Examen & Soins
Examination & Care Sets - Diagnostik- & Pflege Sets - Equipos cuidado y examen

SONDES

Probes - Zahnsonden - sondas exploradores

DIAGNOSTIC

Sondes
Probes - Zahnsonden - Sondas exploradores



Sondes spéciales special probes

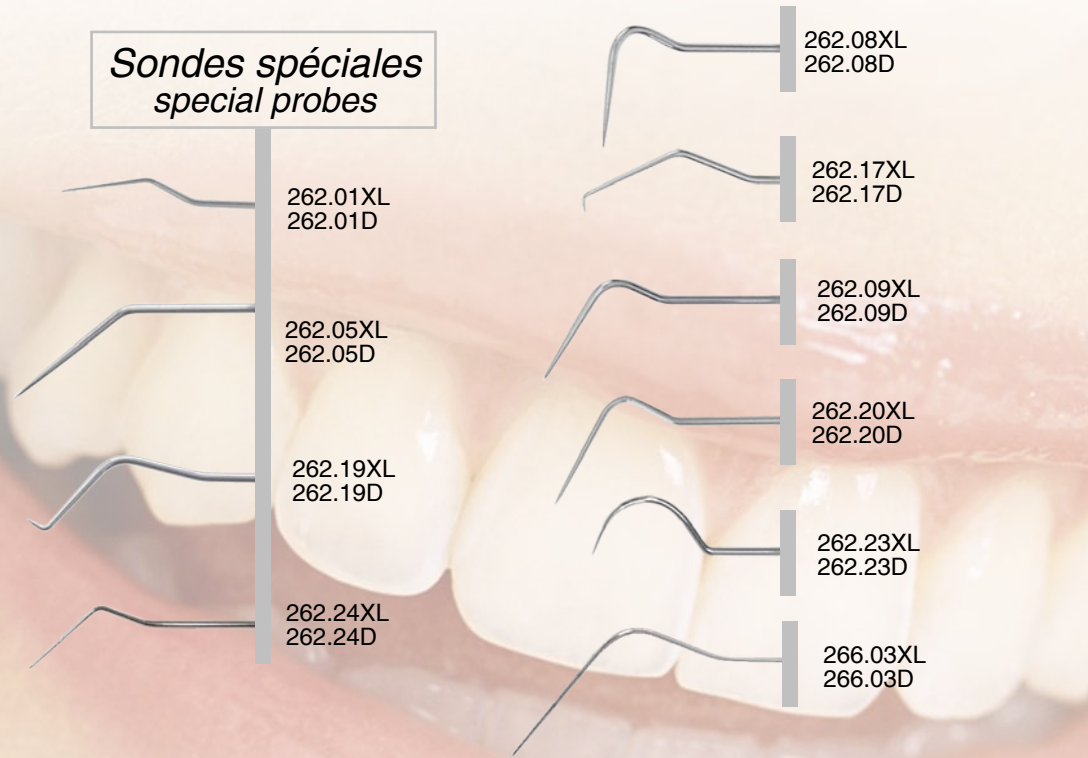

- 262.01XL
262.01D
- 262.05XL
262.05D
- 262.19XL
262.19D
- 262.24XL
262.24D

- 262.08XL
262.08D
- 262.17XL
262.17D
- 262.09XL
262.09D
- 262.20XL
262.20D
- 262.23XL
262.23D
- 266.03XL
266.03D

XL Style

Ref.	€ HT
262.01XL	17,10
262.05XL	17,10
262.06XL	13,58
262.07XL	13,58
262.08XL	13,58
262.09XL	13,58
262.17XL	13,58
262.19XL	17,10
262.20XL	13,58
262.23XL	13,58
262.24XL	17,10
263.05XL	27,27
263.06XL	27,27
263.07XL	27,27
266.03XL	14,75
268.02XL	27,27
269.02XL	27,27



Design

- 263.07XL
263.07D
- BRIAULT B11
- 268.02XL
268.02D
- WESTON W12
- 269.02XL
269.02D

Ref.	€ HT
262.01D	9,97
262.05D	9,97
262.06D	8,59
262.07D	8,59
262.08D	8,59
262.09D	8,59
262.17D	8,59
262.19D	9,97
262.20D	8,59
262.23D	8,59
262.24D	9,97
263.05D	17,40
263.06D	17,40
263.07D	17,40
266.03D	10,08
268.02D	17,40
269.02D	17,40

PRECELLES
Tweezers - Zahnpinzetten - Pinzas



Ref.	€ HT
219.01	14,75
219.02	14,75
220.01	13,58
220.02	13,58
220.02S	14,75
221.05	13,58
222.01	13,90
222.02	13,90
222.03	13,90
223.00	9,97
227.00	9,23
227.02	31,19
227.04	32,36



Précélles auto-fermantes

Self locking tweezers
Pinzetten mit Schloß
Pinzas de cierre automatico

Précélles
DIAGNOSTIC

Tweezers - Zahnpinzetten - Pinzas

WHITE (W.H.E.)



manche XL Style handle

204.01XL



manche Design handle

204.02D



Largeur 2,65mm

204.03XL
204.03D

Ø 1,1mm

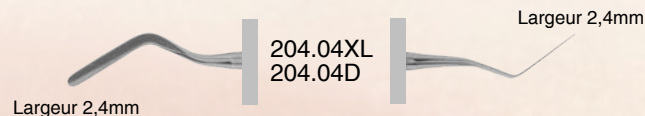

Largeur 2,4mm

204.04XL
204.04D

Largeur 2,4mm

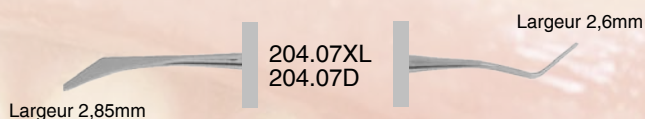

Largeur 2,85mm

204.07XL
204.07D

Largeur 2,6mm

XL Style

Ref.	€ HT
199.00XL	38,19
199.01XL	38,19
202.03XL	29,49
204.01XL	31,61
204.02XL	31,61
204.03XL	31,61
204.04XL	20,69
204.07XL	31,61
205.01XL	29,49
205.02XL	29,49
205.04XL	29,49
208.01XL	22,92
208.02XL	22,92
208.03XL	22,92
208.05XL	22,92
208.06XL	20,69

WILLIAM DIRIGO (W.D.)

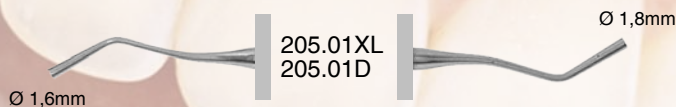

Ø 1,6mm

205.01XL
205.01D

Ø 1,8mm

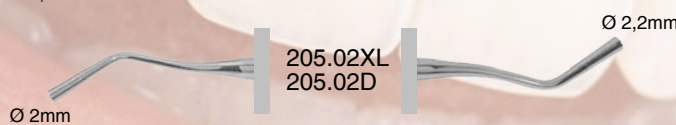

Ø 2mm

205.02XL
205.02D

Ø 2,2mm

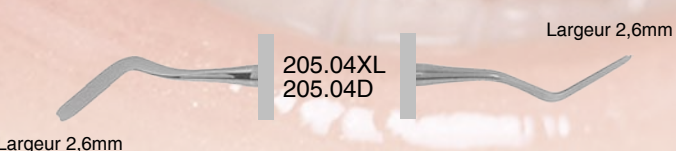

Largeur 2,6mm

205.04XL
205.04D

Largeur 2,6mm

Design

SPECIAL (L.S.P.)

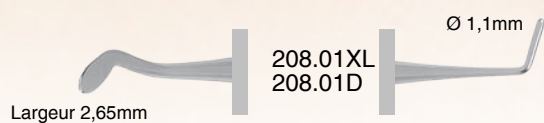

Largeur 2,65mm

208.01XL
208.01D

Ø 1,1mm



Largeur 2,65mm

208.02XL
208.02D

Ø 1,4mm

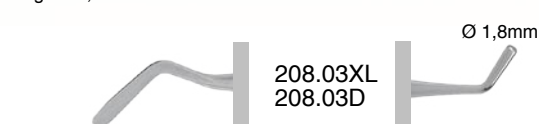

Largeur 2,5mm

208.03XL
208.03D

Ø 1,8mm



Largeur 2mm

208.05XL
208.05D

Ø 1,9mm

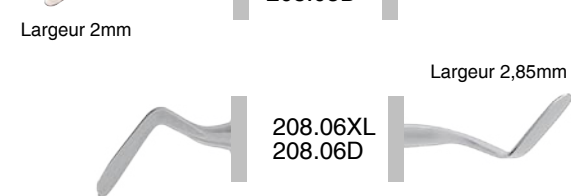

Largeur 2,5mm

208.06XL
208.06D

Largeur 2,85mm

COMPOSITE FACE PROXIMALE

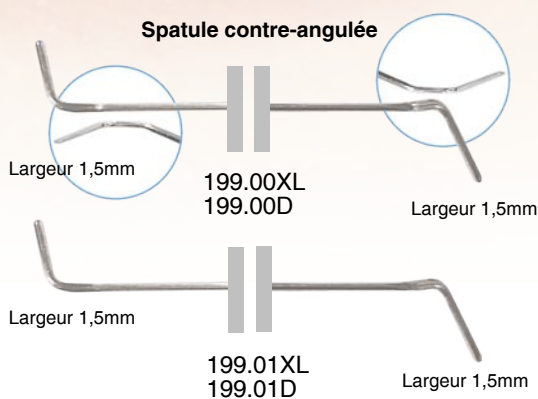

Spatule contre-angulée

Largeur 1,5mm

199.00XL
199.00D

Largeur 1,5mm

Largeur 1,5mm

199.01XL
199.01D

Largeur 1,5mm

P.F.I.D.



Largeur 2,65mm

202.03XL
202.03D

Ø 1,1mm

Ref.	€ HT
199.00D	35,25
199.01D	35,25
202.03D	20,79
204.01D	20,69
204.02D	20,69
204.03D	20,69
204.04D	13,26
204.07D	20,69
205.01D	13,58
205.02D	13,58
205.04D	13,58
208.01D	11,88
208.02D	11,88
208.03D	11,88
208.05D	11,88
208.06D	13,26

Jusqu'à épuisement des stocks
 Until the end of stocks / So langer der Vorrat reicht / Hasta el final del existencia

HEIDEMANN (H.E.I.)

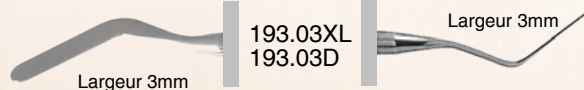
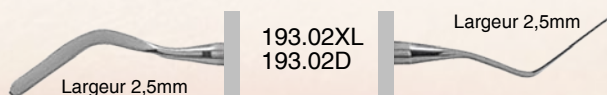

(N.P.H.)

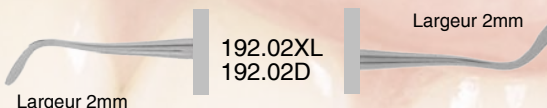
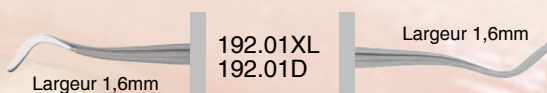

Nouveau revêtement en **Nitride de Zirconium (ZrN)**
REDUIT L'ADHERENCE DES AMALGAMES sur les instruments.

MATERIAU BIOCOMPATIBLE:

Non toxique, Non irritant, Non sensibilisant

HEIDEMANN (H.E.I.)

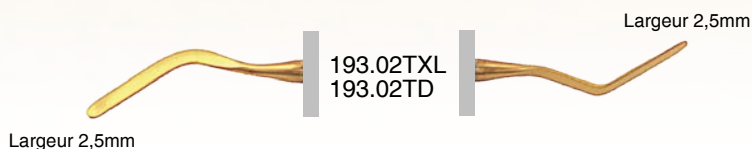
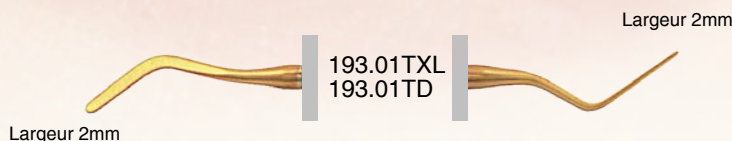
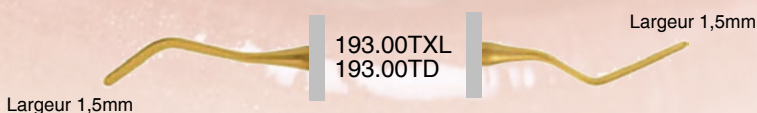

(N.P.H.)

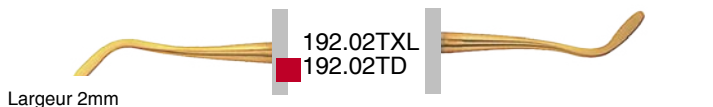

SPECIAL (L.S.P.)

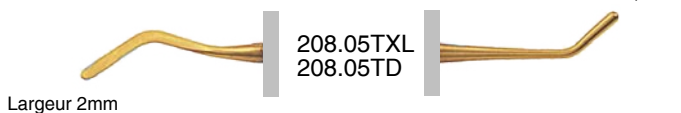

XL Style

Ref.	€ HT
192.01XL	27,27
192.02XL	27,27
193.00XL	20,69
193.01XL	20,69
193.02XL	20,69
193.03XL	20,69
199.00XL	38,19
199.01XL	38,19

Design

Ref.	€ HT
192.01D	20,69
192.02D	20,69
193.00D	13,26
193.01D	13,26
193.02D	13,26
193.03D	13,26
199.00D	35,25
199.01D	35,25

XL Style

Ref.	€ HT
192.02TXL	38,19
193.00TXL	38,19
193.01TXL	38,19
193.02TXL	38,19
208.05TXL	38,19

Design

Ref.	€ HT
192.02TD	27,27
193.00TD	22,28
193.01TD	22,28
193.02TD	22,28
208.05TD	22,28



*manche **XL Style** handle*

206.01XL



*manche **Design** handle*

206.02D

BOYD WALLIS (B.W.)

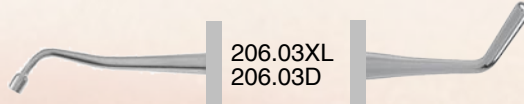

206.03XL
206.03D

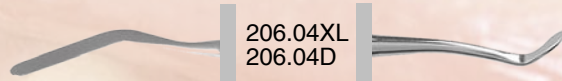

206.04XL
206.04D



206.05XL
206.05D

WOODSON

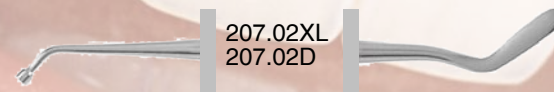

207.02XL
207.02D

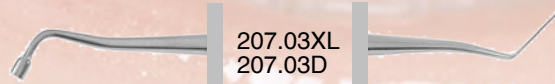

207.03XL
207.03D

WESTCOTT

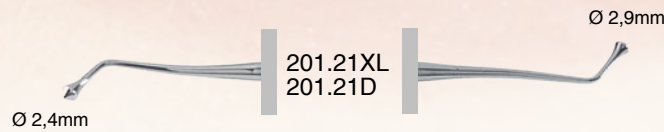

Ø 2,4mm

201.21XL
201.21D

Ø 2,9mm

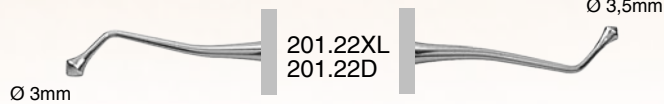

Ø 3mm

201.22XL
201.22D

Ø 3,5mm

LADMORE (L.A.D.)



209.02XL
209.02D

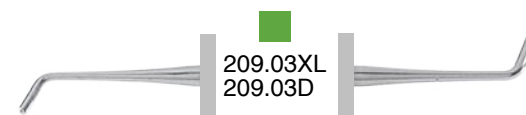

209.03XL
209.03D

JLM 6 ED

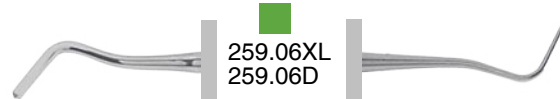

259.06XL
259.06D

XL Style

Ref.	€ HT
201.21XL	25,04
201.22XL	25,04
206.01XL	29,49
206.02XL	29,49
206.03XL	29,49
206.04XL	29,49
206.05XL	27,16
207.02XL	27,80
207.03XL	27,80
209.02XL	29,49
209.03XL	29,49
259.06XL	32,57

Design

Ref.	€ HT
201.21D	14,96
201.22D	14,96
206.01D	20,69
206.02D	20,69
206.03D	20,69
206.04D	20,69
206.05D	17,29
207.02D	18,46
207.03D	18,46
209.02D	21,22
209.03D	21,22
259.06D	25,67

Fabrication sur demande
Manufactured upon request / Auf Anfrage / A petición

FOULOIRS F.O.C



XLStyle

Ref.	€ HT
169.01XL	22,92
169.02XL	22,92
169.03XL	22,92
173.00XL	22,92
173.01XL	22,92
173.02XL	22,92
173.03XL	22,92
173.04XL	22,92
173.05XL	22,92
174.08XL	22,92
174.09XL	22,92
202.02XL	29,49

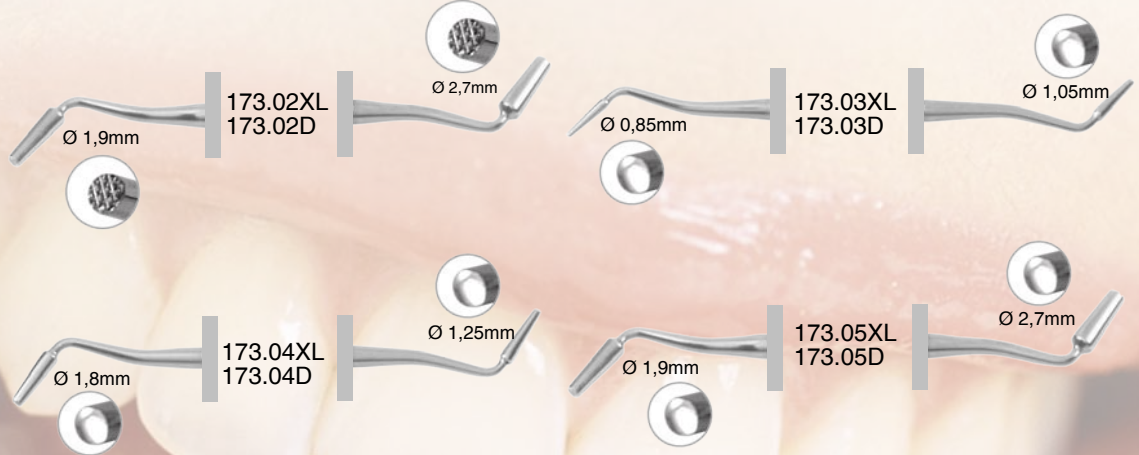

FOULOIRS

Design

Ref.	€ HT
169.01D	18,57
169.02D	18,57
169.03D	18,57
173.00D	14,00
173.01D	14,00
173.02D	14,00
173.03D	14,00
173.04D	14,00
173.05D	14,00
174.08D	14,00
174.09D	14,00
202.02D	20,79

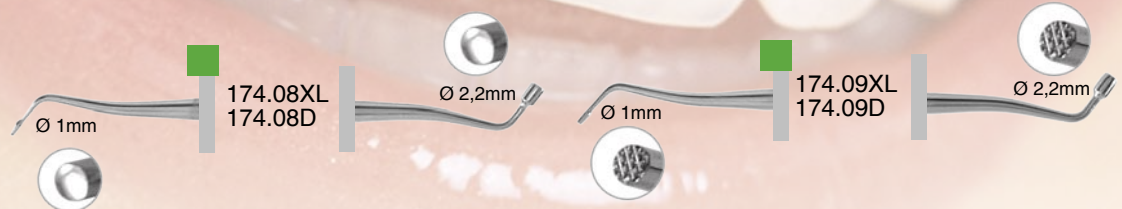

MORTONSON

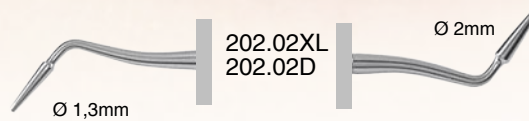

FOULOIRS SIMPLES



 Fabrication sur demande
Manufactured upon request / Auf Anfrage / A petition

FOULOIRS DOUBLES

Amalgam instruments - Amalgam-Instrumenten - Instrumentos para amalgama

Fouloirs Doubles RESTAURATION
Amalgam instruments - Amalgam-Instrumenten - Instrumentos para amalgama

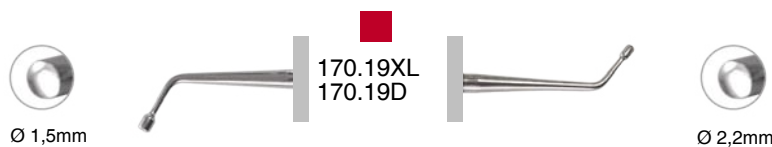
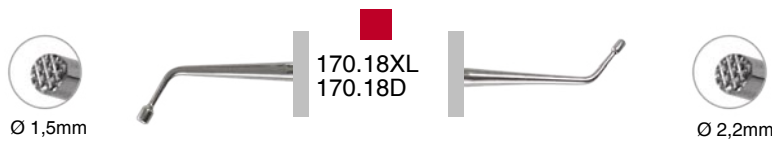
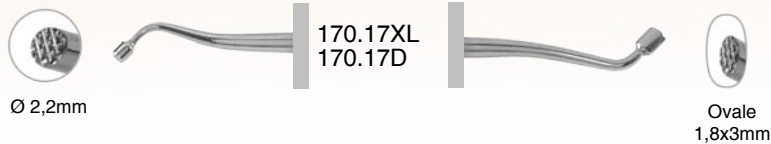
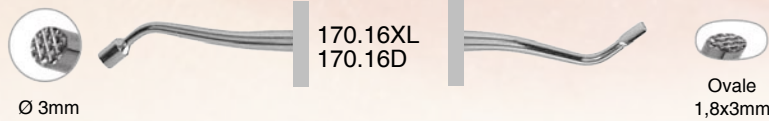
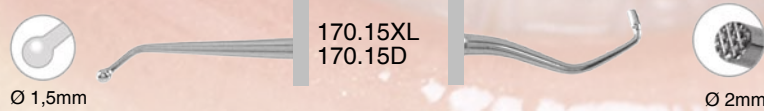
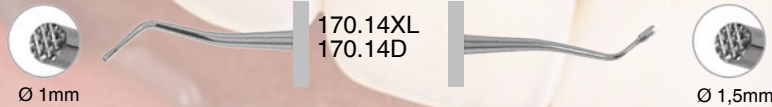
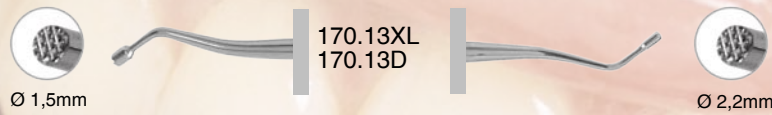

XL Style

Ref.	€ HT
170.10XL	28,30
170.11XL	28,30
170.12XL	28,30
170.13XL	25,04
170.14XL	25,04
170.15XL	34,90
170.16XL	34,90
170.17XL	34,90
170.18XL	34,90
170.19XL	34,90

Design

Ref.	€ HT
170.10D	21,15
170.11D	21,15
170.12D	21,15
170.13D	16,34
170.14D	16,34
170.15D	27,27
170.16D	27,27
170.17D	27,27
170.18D	27,27
170.19D	27,27

Jusqu'à épuisement des stocks
Until the end of stocks / So langer der Vorrat reicht / Hasta el final del existencia

CLEOID

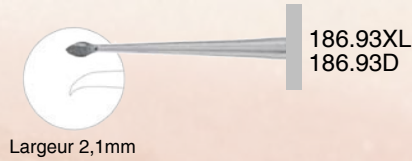

ROMEROWSKI

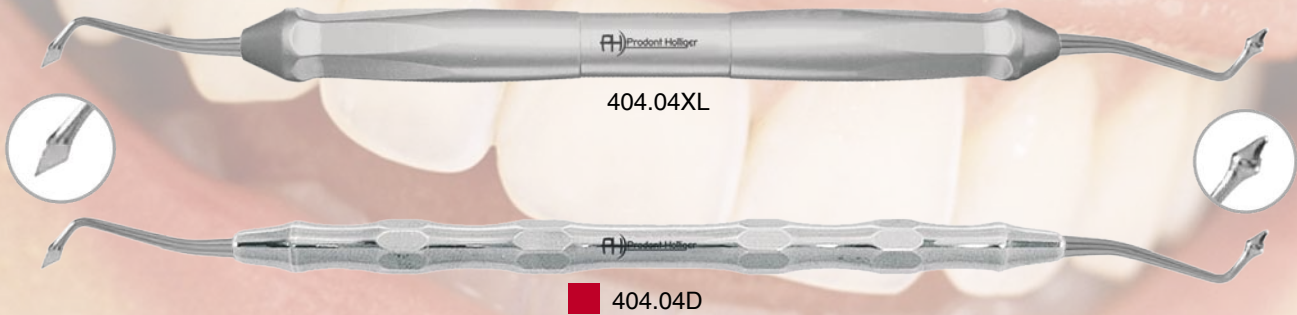

XL Style

Ref.	€ HT
186.05XL	38,19
186.89XL	38,19
186.92XL	38,19
186.93XL	38,19
191.03XL	37,13
191.04XL	31,61
404.04XL	31,61

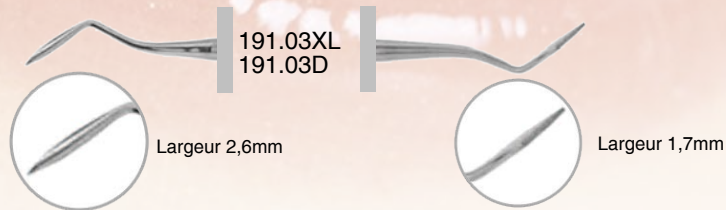

HOLLEBACK

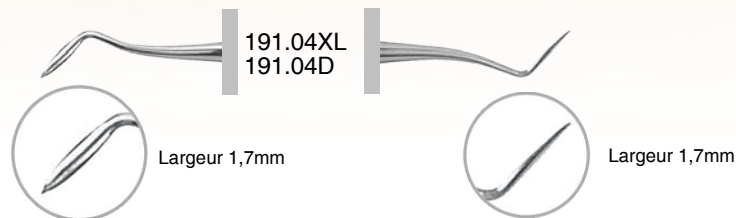

Design

Ref.	€ HT
186.05D	29,95
186.89D	27,27
186.92D	27,27
186.93D	27,27
191.03D	21,64
191.04D	21,64
404.04D	22,92

UWD / DISCOÏD CLEOÏD

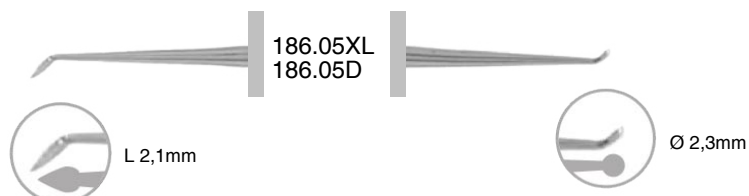

Instruments pour Fils de Rétraction Gingivale
 Gingival retraction thread instruments - Zurückziehen des Zahnfleisches - Retraccion de la encia

Instruments pour Fils de Rétraction Gingivale
 RESTAURATION
 Instruments for Gingival Retraction Thread - Zurückziehen des Zahnfleisches - Retraccion de la encia



manche **XLStyle** handle

154.02XL

Cranté /saw edge /mit Zahnung /con dientes

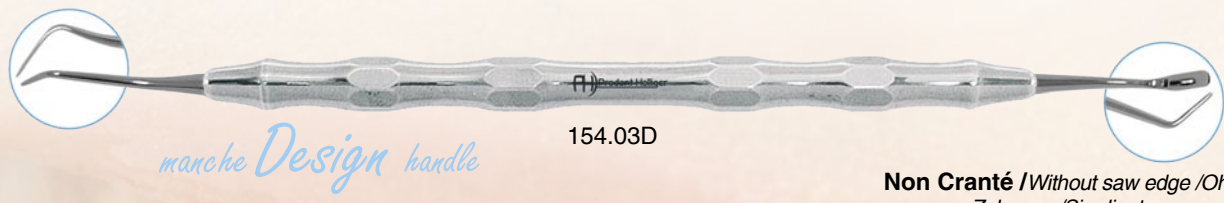

manche **Design** handle

154.03D

Non Cranté /Without saw edge /Ohne Zahnung /Sin dientes

Pour pansements provisoires, couronnes et bridges

Temporary bandages, crowns and bridges
 Provisorischer Zahnverband, Kronen, Brücken
 Vendajes temporales, coronas, puentes



170.00XL
 170.00D

Pour fond de cavité

Cavity bottom / Kavitätsböden
 Fondo de cavidad

XLStyle

Ref.	€ HT
154.02XL	25,67
154.03XL	25,67
170.00XL	35,96
170.01XL	40,42
170.02XL	40,42

Design

Ref.	€ HT
154.02D	17,29
154.03D	17,29
170.00D	19,90
170.01D	20,69
170.02D	20,69

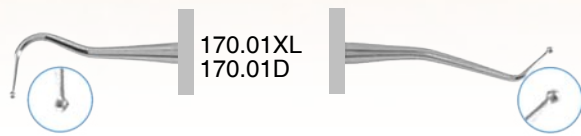

170.01XL
 170.01D

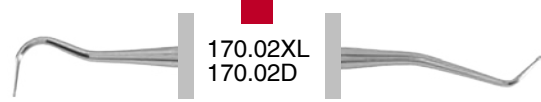

170.02XL
 170.02D

BRUNISSOIRS

Burnishers - Brünierer - Bruñidores



108.15XL

manche **XLStyle** handle



108.15D

manche **Design** handle

XLStyle

Ref.	€ HT
106.28XL	32,78
106.29XL	32,78
107.32XL	39,25
107.33XL	39,25
107.34XL	39,25
108.15XL	30,55
108.16XL	30,55
108.17XL	30,55
109.48XL	69,91
111.00XL	50,18
170.48XL	86,25
201.20TXL	33,84
201.20XL	25,04

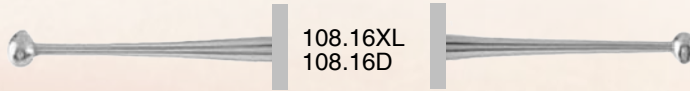

108.16XL
108.16D

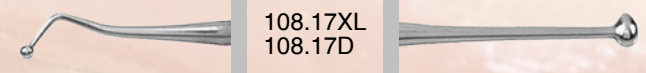

108.17XL
108.17D

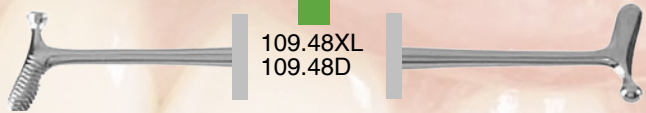

109.48XL
109.48D

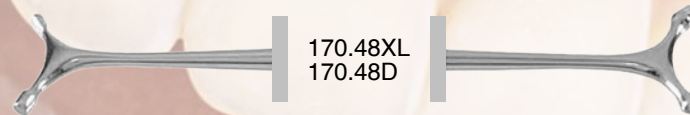

170.48XL
170.48D

BENETT

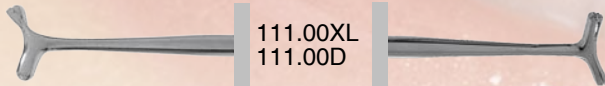

111.00XL
111.00D

WESTCOTT

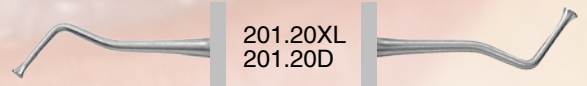

201.20XL
201.20D



201.20TXL
201.20TD

Design

Ref.	€ HT
106.28D	21,34
106.29D	21,34
107.32D	29,49
107.33D	29,49
107.34D	29,49
108.15D	23,98
108.16D	23,98
108.17D	23,98
109.48D	45,83
111.00D	38,72
170.48D	53,47
201.20D	14,96
201.20TD	18,57



106.28XL



106.29D



107.32XL
107.32D



107.33XL
107.33D



107.34XL
107.34D

■ Fabrication sur demande
Manufactured upon request / Auf Anfrage / A petición

■ Jusqu'à épuisement des stocks
Until the end of stocks / So langer der Vorrat reicht / Hasta el final del existencia

EXCAVATEURS

Excavators - Exkavatoren - Excavadores

Excavateurs RESTAURATION
Excavators - Exkavatoren - Excavadores

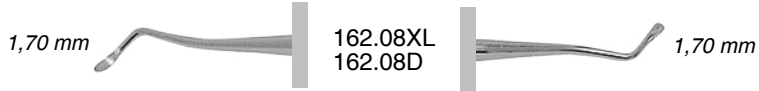
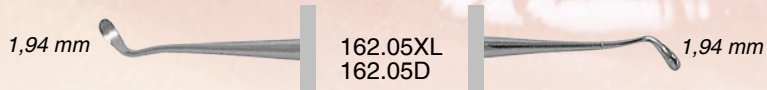
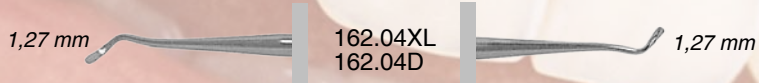
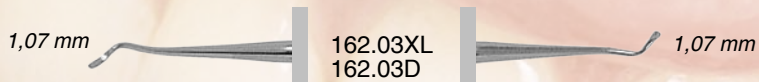
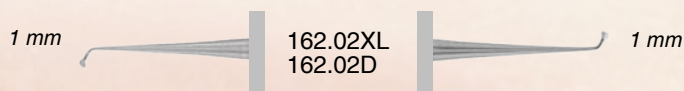
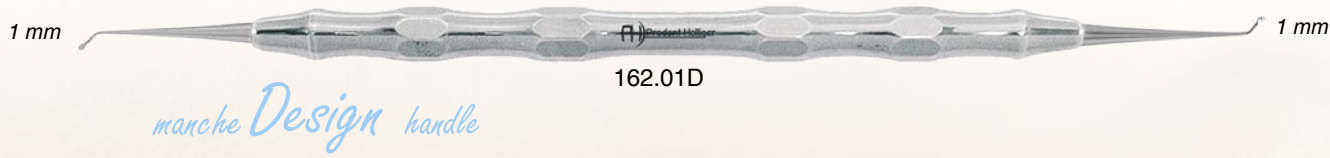

XL Style

Ref.	€ HT
162.00XL	30,02
162.01XL	30,02
162.02XL	30,02
162.03XL	30,02
162.04XL	30,02
162.05XL	30,02
162.06XL	30,02
162.07XL	30,02
162.08XL	30,02

Design

Ref.	€ HT
162.00D	20,69
162.01D	20,69
162.02D	20,69
162.03D	20,69
162.04D	20,69
162.05D	20,69
162.06D	20,69
162.07D	20,69
162.08D	20,69

EXCAVATEURS

Excavators - Exkavatoren - Excavadores



163.05XL

manche **XL Style** handle



163.14D

manche **Design** handle

XL Style

Ref.	€ HT
163.05XL	30,02
163.14XL	30,02
163.17XL	30,02
163.18XL	30,02
163.19XL	30,02
163.20XL	30,02
164.16XL	40,42
164.17XL	40,42
164.18XL	40,42
164.19XL	40,42
164.20XL	40,42
164.21XL	40,42
164.22XL	40,42
164.23XL	40,42



163.17XL

163.17D

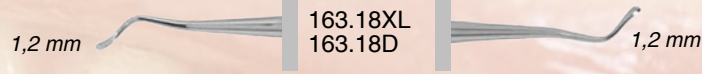

163.18XL

163.18D

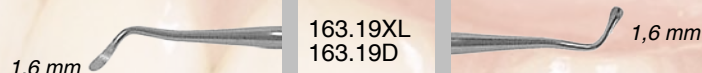

163.19XL

163.19D

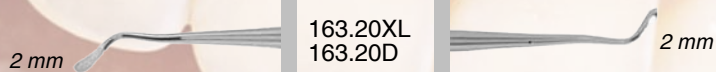

163.20XL

163.20D

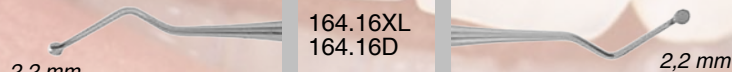

164.16XL

164.16D

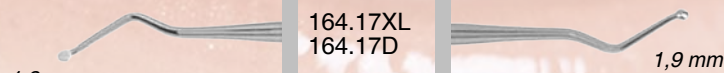

164.17XL

164.17D

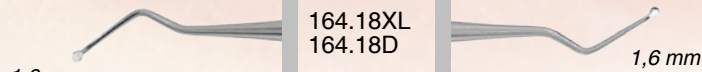

164.18XL

164.18D

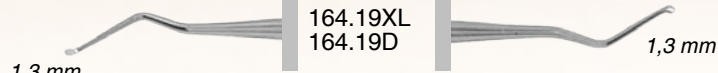

164.19XL

164.19D

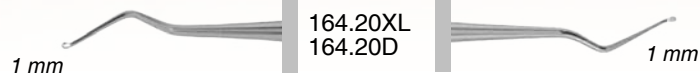

164.20XL

164.20D

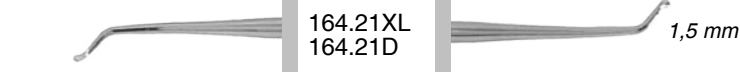

164.21XL

164.21D

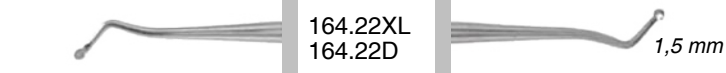

164.22XL

164.22D

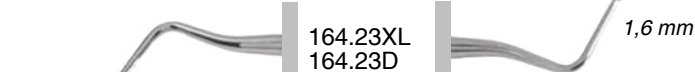

164.23XL

164.23D

Design

Ref.	€ HT
163.05D	20,69
163.14D	20,69
163.17D	20,69
163.18D	20,69
163.19D	20,69
163.20D	20,69
164.16D	31,61
164.17D	31,61
164.18D	31,61
164.19D	31,61
164.20D	31,61
164.21D	31,61
164.22D	31,61
164.23D	31,61

SPATULES à CIMENT SIMPLES

SimpleCement spatulas - Zementspatel - Espatulas para cementar

RESTAURATION

Spatules à ciment
Cement spatulas - Zementspatel - Espatulas para cementar



246.10XL

246.11D

manche
XLStyle
handle

manche
Design
handle

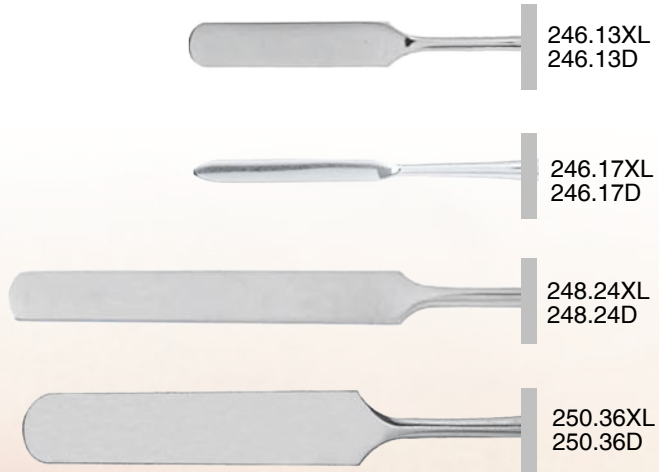

246.13XL
246.13D

246.17XL
246.17D

248.24XL
248.24D

250.36XL
250.36D

Ultra Flexibles

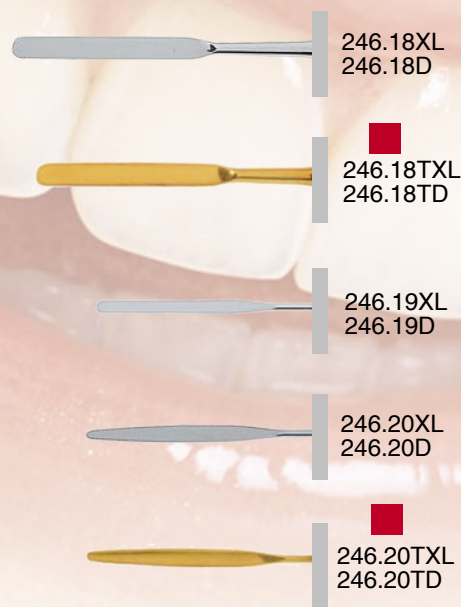

246.18XL
246.18D

246.18TXL
246.18TD

246.19XL
246.19D

246.20XL
246.20D

246.20TXL
246.20TD

XLStyle

Ref.	€ HT
246.10XL	28,33
246.11XL	28,33
246.13XL	28,33
246.17XL	28,33
246.18TXL	40,42
246.18XL	27,27
246.19XL	27,27
246.20TXL	40,42
246.20XL	27,27
248.24XL	28,86
250.36XL	28,86

Design

Ref.	€ HT
246.10D	21,64
246.11D	21,64
246.13D	21,64
246.17D	21,64
246.18D	22,75
246.18TD	27,27
246.19D	22,75
246.20D	22,75
246.20TD	27,27
248.24D	25,10
250.36D	25,10

ACCESSOIRES

Accessories - Verschiedenes zubehör - Accesorios

Godets Dappen en Verre

Glass dishes - Dappenglas - Pocillos



10ml / 2ml

1592.00

1592.01

1592.02

1592.03



Godets Dappen Recyclables

disposable dishes - Becher - Pocillos



1593.04

1593.00

1593.01

1593.03

1593.02

x100

Ref.	€ HT
1592.00	1,59
1592.01	1,59
1592.02	1,59
1592.03	1,59
1593.00	10,50
1593.01	10,50
1593.02	10,50
1593.03	10,50
1593.04	10,50

Jusqu'à épuisement des stocks
Until the end of stocks / So langer der Vorrat reicht / Hasta el final del existencia

SPATULES à CIMENT DOUBLES
 Double Cement spatulas - Zementspatel - Espatulas para cementar

RESTAURATION

Spatules à ciment
 Cement spatulas - Zementspatel - Espatulas para cementar



252.01XL

*manche **XLStyle** handle*

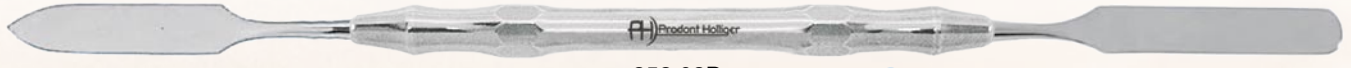

252.02D

*manche **Design** handle*

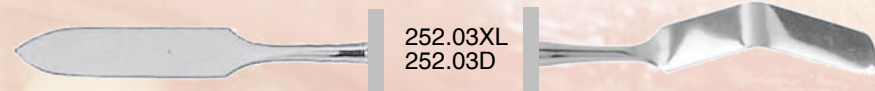
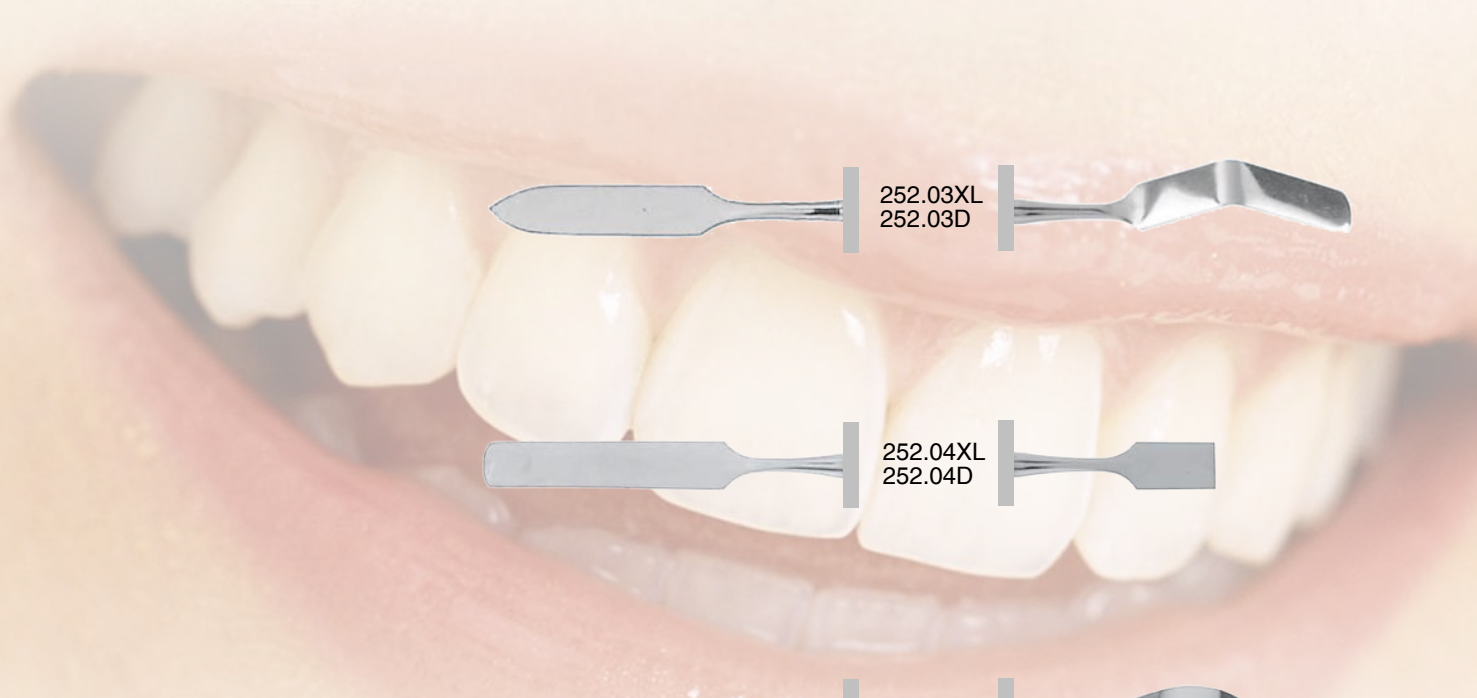

252.03XL
252.03D



252.04XL
252.04D

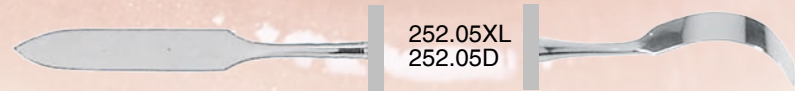

252.05XL
252.05D

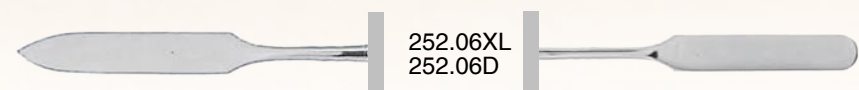

252.06XL
252.06D

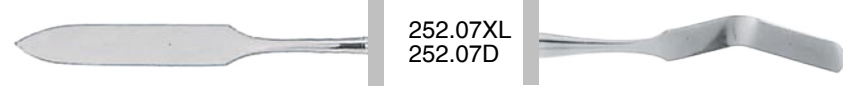

252.07XL
252.07D

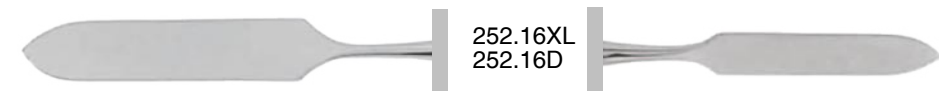

252.16XL
252.16D

XLStyle

Ref.	€ HT
252.01XL	24,51
252.02XL	24,51
252.03XL	32,15
252.04XL	32,15
252.05XL	32,15
252.06XL	24,51
252.07XL	32,15
252.16XL	32,15

Design

Ref.	€ HT
252.01D	19,10
252.02D	19,10
252.03D	25,10
252.04D	25,10
252.05D	25,10
252.06D	19,10
252.07D	25,10
252.16D	25,10

Couteau à événements pour empreintes en 2 temps

Knife used to eliminate silicone excess
 Messer zur Entfernung von Silikon-Abdrucküberschuß
 Cuchillo para eliminar el exceso de silicona



453.00D

manche Design handle



Anneau tranchant
 Sharp ring
 Scharfe ende
 Cortantes



Lame 3 tranchants
 3 sharp sides blade
 3 Scharfe ende
 Cortantes

RESTAURATION

Empreintes, Pose et Dépose Couronnes

Enfonce-couronne

Crown setter
 Kronensetzer
 Para colocar coronas

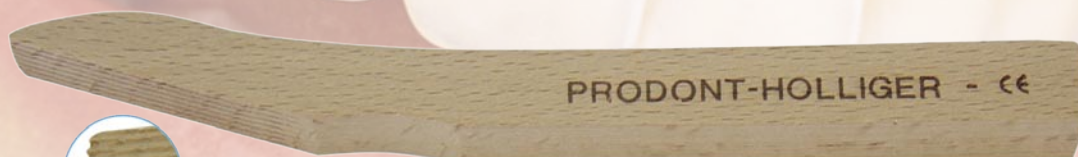

3087.00



Dépose couronne

Crown remover
 Kronenabnehmer
 Para quitar coronas



105.00

Ref.	€ HT
105.00	77,55
3087.00	4,88
453.00D	51,35



Précelle MILLER pour papier à articuler

*Tweezer for articulating paper
Artikulationspapier Pinzette
Pinza para papel de articular*



Pinces à tenons

*Nerve instruments
Wurzelkanalinstrumente
Pinzas para nervios*



Ref.	€ HT
433.00	20,69
750.00	60,05
751.00	60,05

N°1 Bords Minces Droits
Thin straight edges



3040.U6 Haut /Upper part /OK /Superior

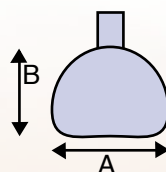

Supérieur /Upper part /OK /Superior

Tailles /sizes AxB (mm)	Ref.
61x47	3040.U1
64x51	3040.U2
66x53	3040.U3
69x57	3040.U4
71x60	3040.U5
73x62	3040.U6

7,53 € HT



3040.L6 Bas /Lower part /UK /Inferior

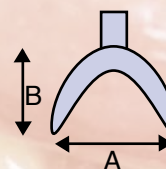

Inférieur /Lower part /UK /Inferior

Tailles /sizes AxB (mm)	Ref.
55x47	3040.L1
60x49	3040.L2
72x54	3040.L3
75x57	3040.L4
76x59	3040.L5
78x61	3040.L6

7,53 € HT

Personnalisez vos porte-empreintes grâce à la gravure laser. A partir de 20 pièces , 0,50€ / pièce. GRATUIT dès 100p.
Customize your impression trays with laser etching. Starting from 20 pcs., 0,50€ per unit. **FREE for 100 pcs. and more.**
Personalisieren Sie Ihre Abdrucklöffel durch Lasergravierung. Preis: 0,50€ pro Stück ab 20 Abdrucklöffel bestellt.
Personalice sus porta moldes gracias al grabado láser. A partir de 20 unidades, 0,50€ por unidad.

3040.L4D
Demi porte-empreintes droit
Half impression tray, right
für partielle Abdrücke, rechts
Mitad porta moldes, derecha



3040.L4S
Demi porte-empreintes gauche
Half impression tray, left
für partielle Abdrücke, links
Mitad porta moldes, izquierda

Demi porte-empreinte
Half impression tray
für partielle Abdrücke
Mitad porta moldes

Inférieur /Lower part /UK /Inferior

Tailles /sizes mm	Ref.
----------------------	------

Gauche / left

30x49	3040.L2S
37x57	3040.L4S
39x61	3040.L6S

7,53 € HT

Droite / right

30x49	3040.L2D
37x57	3040.L4D
39x61	3040.L6D

7,53 € HT

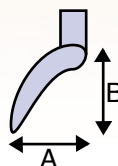



MÉLANGEUR À ALGINATE
Alginate mixer

Page/Seite 83

N°2 Bords rétentifs

Retentive edges
Retentionsrand
Perfil especial

IDEAL POUR ALGINATE

Alginate friendly

9,12 € HT

Supérieur /Upper part /OK /Superior

Tailles /sizes mm	Ref.
61x47	3041.U1
64x51	3041.U2
66x53	3041.U3
69x57	3041.U4
71x60	3041.U5
73x62	3041.U6

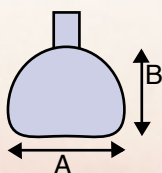

3041.U6 Haut /Upper part /OK /Superior

9,12 € HT

Inférieur /Lower part /UK /Inferior

Tailles /sizes mm	Ref.
55x47	3041.L1
60x49	3041.L2
72x54	3041.L3
75x57	3041.L4
76x59	3041.L5
78x61	3041.L6

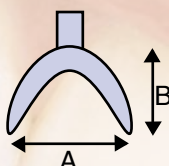

3041.L6 Bas /Lower part /UK /Inferior

Personnalisez vos porte-empreintes grâce à la gravure laser. A partir de 20 pièces, 0,50€ par pièce.

Customize your impression trays with laser etching. Starting from 20 pcs., 0,50€ per unit.

Personalisieren Sie Ihre Abdrucklöffel durch Lasergravierung. Preis: 0,50€ pro Stück ab 20 Abdrucklöffel bestellt.

Personalice sus porta moldes gracias al grabado láser. A partir de 20 unidades, 0,50€ por unidad.

N°3 Plein, Bords rétentifs

Full, Retentive edges
Retentionsrand
Perfil especial

9,12 € HT

Supérieur /Upper part /OK /Superior

Tailles /sizes mm	Ref.
61x47	3050.U1
64x51	3050.U2
66x53	3050.U3
69x57	3050.U4
71x60	3050.U5
73x62	3050.U6

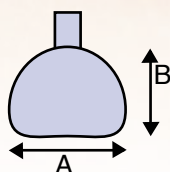

3050.U6 Haut /Upper part /OK /Superior

9,12 € HT

Inférieur /Lower part /UK /Inferior

Tailles /sizes mm	Ref.
55x47	3050.L1
60x49	3050.L2
72x54	3050.L3
75x57	3050.L4
76x59	3050.L5
78x61	3050.L6

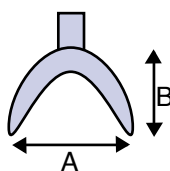

3050.L6 Bas /Lower part /UK /Inferior

ZERFING



TOWNER



I.N.H.



DEVIN



THORPE



DAVENPORT



JAQUETTE



Design

Ref.	€ HT
184.01D	29,95
184.02D	29,95
184.03D	29,95
185.03D	29,95
185.04D	29,95
185.22D	29,95
270.01D	23,98
408.01D	27,27
409.00D	27,27
409.02D	27,27
409.03D	27,27
410.15D	27,27
410.16D	27,27
414.13D	38,19
414.14D	38,19

 **Jusqu'à épuisement des stocks**
Until the end of stocks / So langer der Vorrat reicht / Hasta el final del existencia

 **Fabrication sur demande**
Manufactured upon request

I.N.A.



183.01D

marque Design handle

**UNIQUEMENT
ONLY**



183.02D



183.03D



183.04D



183.06D



183.07D



183.32D



183.33D



183.34D

DARBY PERRY



184.04D



184.05D



184.06D



184.11D

Design

Ref.	€ HT
183.01D	29,95
183.02D	29,95
183.03D	29,95
183.04D	29,95
183.06D	29,95
183.07D	29,95
183.32D	29,95
183.33D	29,95
183.34D	29,95
184.04D	29,95
184.05D	29,95
184.06D	29,95
184.11D	29,95

 Fabrication sur demande
Manufactured upon request / Auf Anfrage / A petición

ORBAN



BUCK

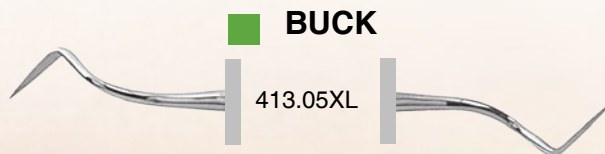

WEDELSTAEDT (W.E.D.)



XL Style

Ref.	€ HT
115.02XL	38,19
115.03XL	38,19
115.09XL	38,19
115.10XL	38,19
115.41XL	38,19
115.42XL	38,19
115.43XL	38,19
115.44XL	38,19
115.48XL	38,19
412.01XL	55,70
413.05XL	55,70

Fabrication sur demande
Manufactured upon request / Auf Anfrage / A petition



XL Style

Ref.	€ HT
271.00XL	35,96
418.00XL	29,49
418.01XL	29,49
419.00XL	38,19

Design

Ref.	€ HT
271.00D	27,27
418.00D	21,64
418.01D	21,64
419.00D	29,71

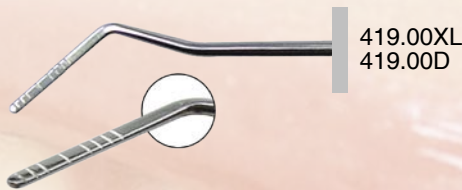

Curettes doubles
 Curettes - Küretten - Curetas

GOLDMAN-FOX

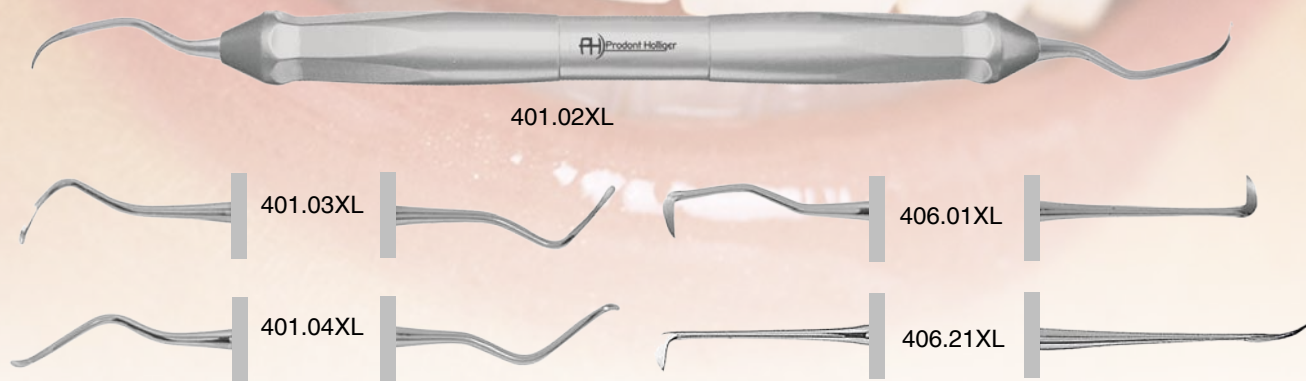

XL Style

Ref.	€ HT
401.02XL	42,54
401.03XL	42,54
401.04XL	42,54
406.01XL	42,54
406.21XL	42,54
403.13XL	38,19
403.17XL	38,19
418.00XL	29,49
418.01XL	29,49
419.00XL	38,19
420.07XL	43,07

MAC CALL

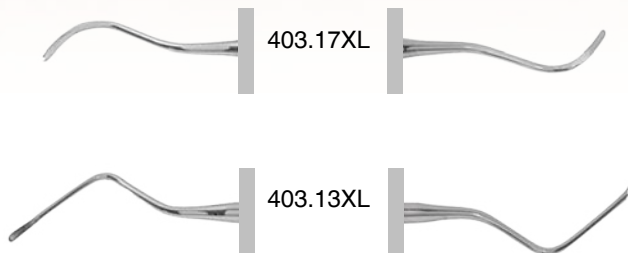

YOUNGER GOOD

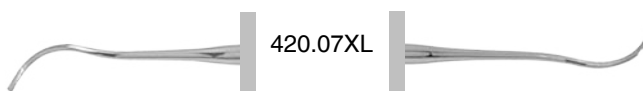

Nouveau revêtement en **Nitru de Zirconium (ZrN)**
Conserve le tranchant des instruments au long cours
MATERIAU BIOCOMPATIBLE:
Non toxique, Non irritant, Non sensibilisant
Adapté au détartrage autour des implants titane.

GRACEY



*manche **XLStyle** handle*

402.01TXL

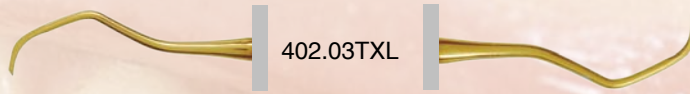

402.03TXL

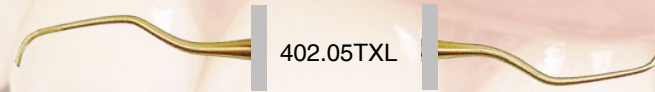

402.05TXL

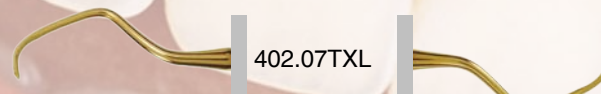

402.07TXL

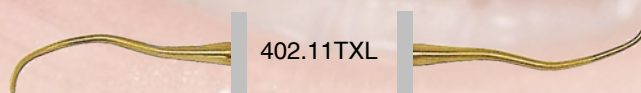

402.11TXL

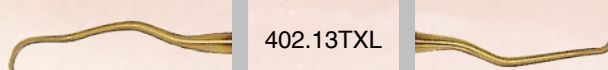

402.13TXL

CRANE KAPLAN

MICRO CK6 COURBE

/ curved / gebogen / curvado



404.05TXL

MICRO CK6 DROIT

straight / gerade / rectas

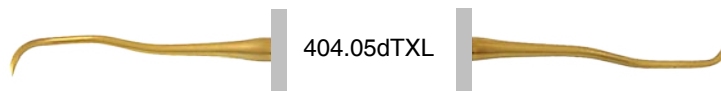

404.05dTXL

XLStyle

Ref.	€ HT
402.01TXL	45,83
402.03TXL	45,83
402.05TXL	45,83
402.07TXL	45,83
402.11TXL	45,83
402.13TXL	45,83
404.05dTXL	44,77
404.05TXL	44,77
404.05TXL	44,77

GRACEY



402.01XL

*manche **XLStyle** handle*

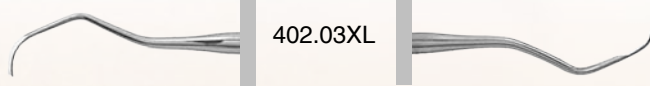

402.03XL

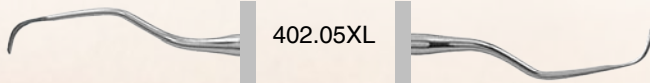

402.05XL

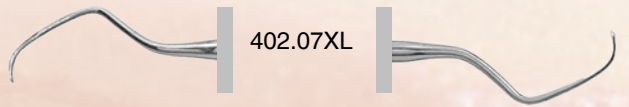

402.07XL

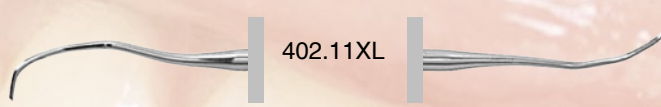

402.11XL

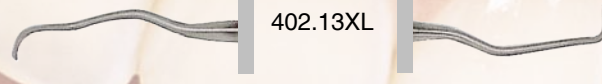

402.13XL

CRANE KAPLAN



CK6 404.06XL

MINI CK6

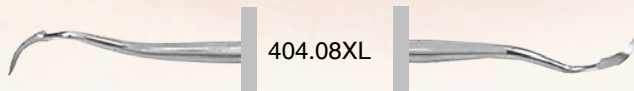

404.08XL

XLStyle

Ref.	€ HT
402.01XL	38,19
402.03XL	38,19
402.05XL	38,19
402.07XL	38,19
402.11XL	38,19
402.13XL	38,19
404.05dXL	38,19
404.05XL	38,19
404.06XL	48,06
404.08XL	42,54

MICRO CK6 droit / *straight / gerade / recto*

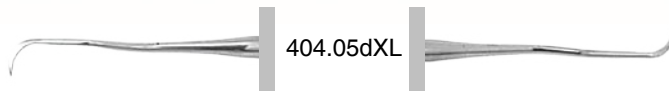

404.05dXL

MICRO CK6 courbe / *curved / gebogen / curvado*

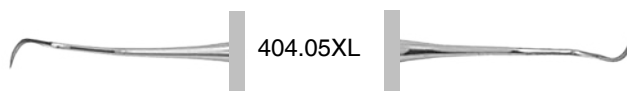

404.05XL

BARD PARKER: La Lame de Bistouri Sans Risque!
Risk-Free Scalpel system



600.03



615.10

Manche de bistouri pour lame jetable stérile avec gaine de protection.
Scalpel handle for disposable sterile blade with plastic shield safety lock



La protection plastique **évite tout risque de coupure** pour placer et retirer la lame.
The plastic shield covers the blade when placing and removing it.



615.10

Ref.	€ HT
600.03	95,90
615.10	4,90

Lame stérile vendue à l'unité (séparément)
1x Sterile blade (sold separately)



1. Placez la lame gainée sur le manche, en toute sécurité.

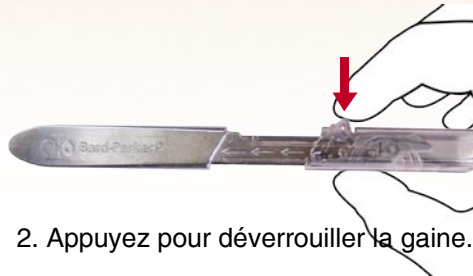

2. Appuyez pour déverrouiller la gaine...

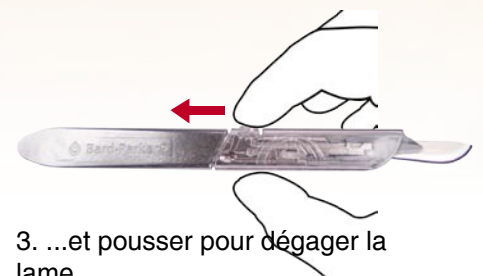

3. ...et pousser pour dégager la lame.

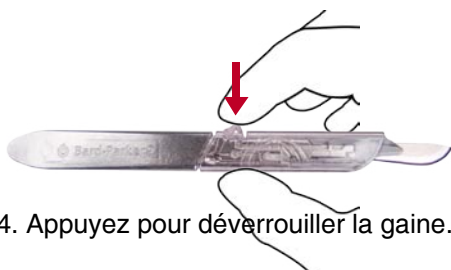

4. Appuyez pour déverrouiller la gaine...

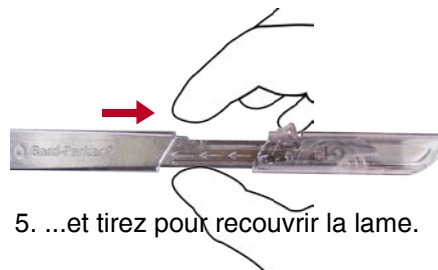

5. ...et tirez pour recouvrir la lame.

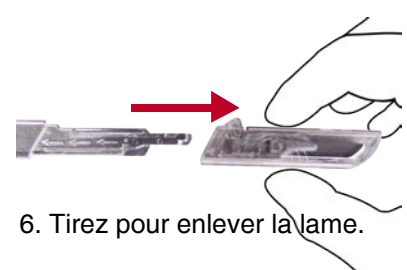

6. Tirez pour enlever la lame.

Bistouris
Scalpels - Skalpelle - Bisturís



manche **XL** Style handle

610.00XL

Meilleure préhension, facile à tourner.
Easy Grip and Roll.



601.03 n°3
12,5cm



**Lames vendues
séparément**
Blades sold separately



615.11
Lames stériles
Sterile blades
n°11
x100



615.15
Lames stériles
Sterile blades n°15
x100

KIRKLAND



414.15XL



414.16XL



411.15XL

Ref.	€ HT
615.11	39,25
615.15	39,25
411.15XL	55,70
414.15XL	51,35
414.16XL	51,35
601.03	15,28
610.00XL	38,30

**NOUVEAUTÉ
NEW**

Décolleur du Dr ROOS
Periosteal elevators - Raspatorien - Periostomo

PARODONTOLOGIE



manche **XLStyle handle** 407.05XL

Ref. €HT
407.05XL 138,54

3 en 1

Tous les avantages d'un décolleur, d'un écarteur et de la vision d'un excellent miroir!

3 in 1

CURE & SEE

Décolleurs
Periosteal elevators - Raspatorien - Periostomo

Décolleurs de MOLT
Periosteal elevators - Raspatorien - Periostomo



Largeur 4,5mm

407.07XL

Largeur 3,5mm



Largeur 5,5mm

407.08D

Largeur 4mm

manche **Design handle**

XLStyle

Ref.	€ HT
407.07XL	42,54
407.08XL	42,54
407.09XL	53,47

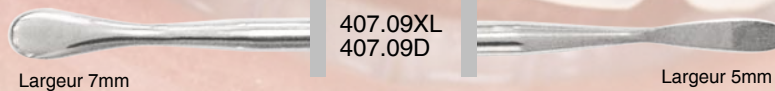

Largeur 7mm

407.09XL
407.09D

Largeur 5mm

Design

Ref.	€ HT
407.07D	35,96
407.08D	35,96
407.09D	44,77

Précettes à Marquer GOLDMAN-FOX
Pocket Markers / Taschenmarkierung / para marcar



417.01

Marquage à droite 15 cm

Pocket Markers, right / Taschenmarkierung, rechts / para marcar, derecho



Ref.	€ HT
417.01	19,52
417.02	19,52

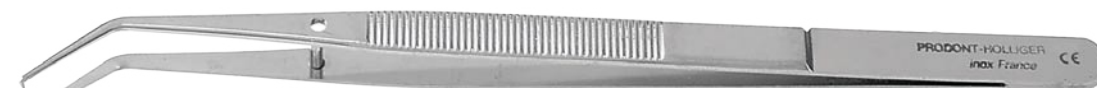

417.02

Marquage à gauche 15 cm

Pocket Markers, left / Taschenmarkierung, links / para marcar, izquierdo



Précelles, Porte-aiguille
Suture forceps - Nahtpinzetten - Pinzas



428.00
Sutures, à oeillets 15 cm



429.00
Sutures, oeillets ouverts 15 cm



432.00
CORN suture 15 cm

MATHIEU

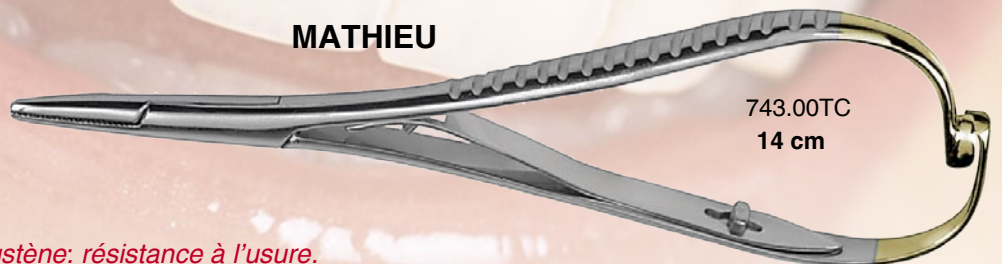

743.00TC
14 cm

*TC: Mors Carbone de Tungstène: résistance à l'usure.
 Tungsten carbide / Tungsten Carbid / Carburo de tungsteno*



744.00TC
17 cm

CASTROVIEJO



Mors droits
Straight / Gerade / Recto

747.01TC



Mors courbes
Curved / Gebogen / Curvado

747.02TC

Ref.	€ HT
428.00	20,79
429.00	20,79
432.00	30,34
743.00	42,54
743.00TC	92,83
744.00	42,54
744.00TC	92,83
747.01TC	213,03
747.02TC	213,03

Syndesmotomes du Dr BERNARD

Syndesmotome - syndesmotomos

Lames Interchangeables

Removable blades
Auswechselbare einsätze
Puntas intercambiables



Ref. €HT
236.00 36,60

236.00

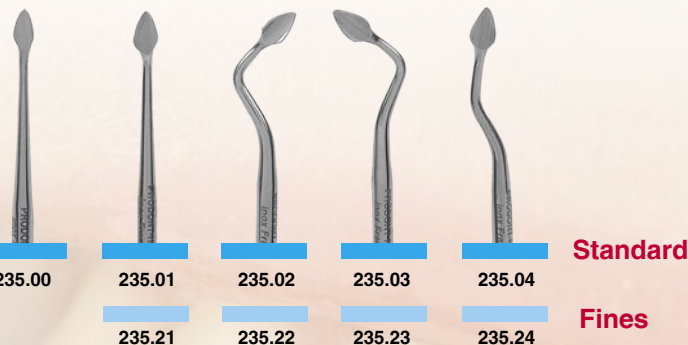

Lames standard
Largeur 4mm
Longueur 7mm
Epaisseur 1,5mm

Ref.	€HT
235.00	14,00
235.01	14,00
235.02	14,00
235.03	14,00
235.04	14,00
235.05	14,00
235.06	14,00
235.07	14,00
235.08	14,00
235.09	14,00
235.11	14,00

Standard

Fines



Lames fines
Largeur 3,3mm
Longueur 6,7mm
Epaisseur 1,5mm

Ref.	€HT
235.21	16,87
235.22	16,87
235.23	16,87
235.24	16,87
235.25	16,87
235.26	16,87
235.27	16,87
235.28	16,87
235.29	16,87

Standard

Fines

Kits Syndesmotomes du Dr BERNARD

Syndesmotome Zätze- syndesmotomos Kits



7,5 cm x 17,5 cm x 3 cm

241.00 **2 manches 236.00, 11 lames standard, boîte aluminium.**

2 handles, 11 standard blades, aluminium box
2 Griffe, 11 Standard-Einsätze, Aluminium Schale
2 mangos, 11 puntas estándar, caja de aluminio

241.01 **2 manches 236.00, 9 lames fines, boîte aluminium.**

2 handles, 9 fine blades, aluminium box
2 Griffe, 9 feine Einsätze, Aluminium Schale
2 mangos, 9 puntas finas, caja de aluminio

241.02 **2 manches 236.00, 9 lames fines, 11 lames standard, boîte aluminium.**

2 handles, 9 fine blades, 11 standard blades, aluminium box
2 Griffe, 9 feine Einsätze, 11 Standard-Einsätze, Aluminium Schale
2 mangos, 9 puntas finas, 11 puntas estándar, caja de aluminio

242.00 **Boîte Aluminium vide**

Empty Box / Schale / Caja

Ref. € HT

241.00	217,38
241.01	221,73
241.02	345,15
242.00	27,27

Syndesmotes du Dr BERNARD à lames fixes
Syndesmote non removable blades - Festsitzende Spitze - syndesmotomos, punta fija

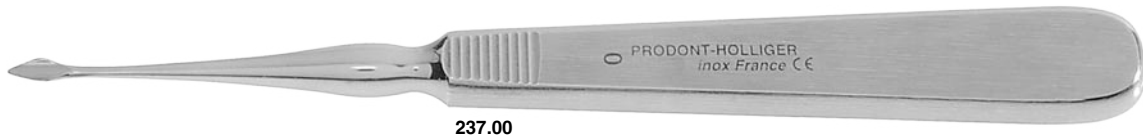

237.00



Standard	237.00	237.01	237.02	237.03	237.04	237.05	237.06	237.07	237.08	237.09	237.11
Fines		237.21	237.22	237.23	237.24	237.25	237.26	237.27	237.28	237.29	

Le Syndesmotome à lame fixe €HT
46,36

Syndesmotes de CHOMPRET
Syndesmote - syndesmotomos

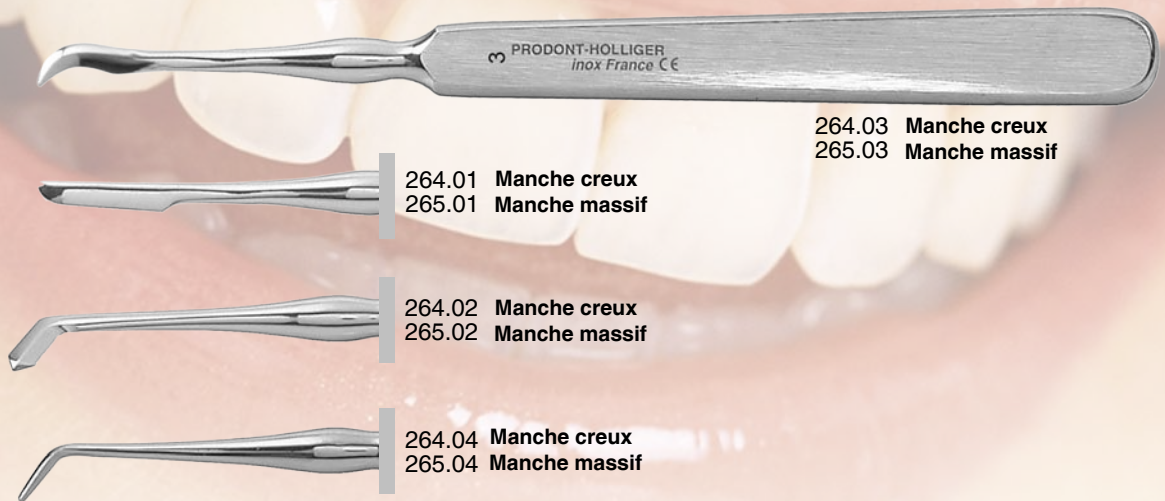

264.03 Manche creux
 265.03 Manche massif

264.01 Manche creux
 265.01 Manche massif

264.02 Manche creux
 265.02 Manche massif

264.04 Manche creux
 265.04 Manche massif

Syndesmotes Périotomes
Syndesmote - syndesmotomos

Ref.	€ HT
158.01	60,47
158.02	60,47
158.03	60,47
264.01	40,31
264.02	40,31
264.03	40,31
264.04	40,31
264.10	43,28
264.11	43,28
264.12	43,28
265.01	56,12
265.02	56,12
265.03	56,12
265.04	56,12

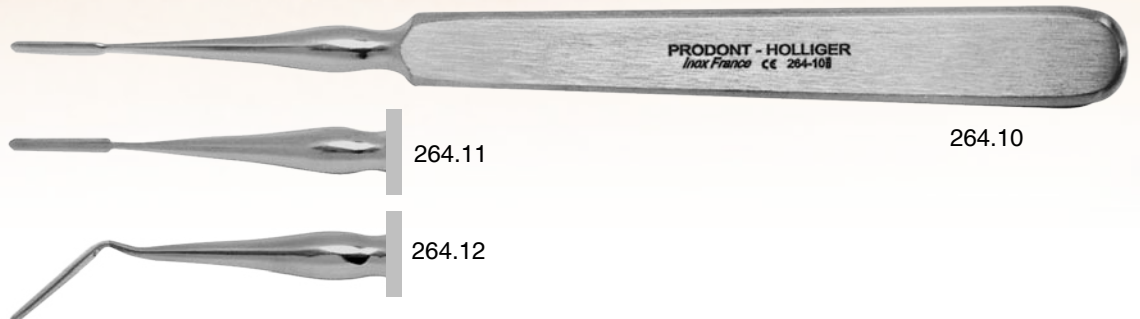

264.11

264.10

264.12

Syndesmotes de WARWICK-JAMES
Syndesmote - syndesmotomos

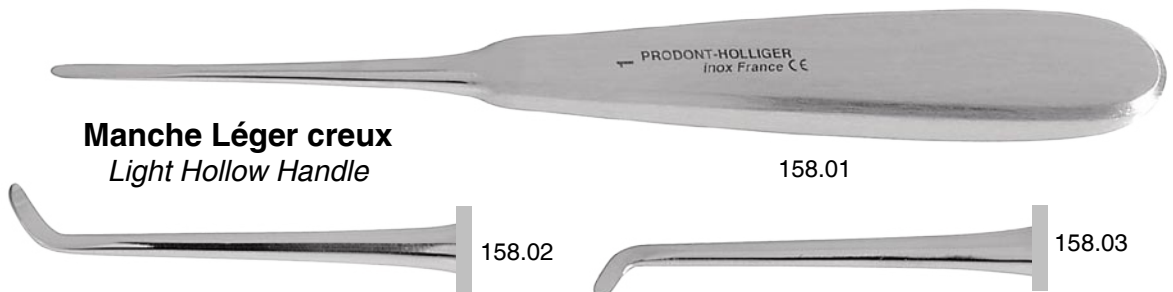

Manche Léger creux
Light Hollow Handle

158.01

158.02

158.03

Syndesmotes
 Syndesmote - Syndesmotomos

Elévateur à lames interchangeables



Manche
Handle/Griff /Mango
159.M

Système de blocage du syndesmotome BERNARD
BERNARD's syndesmotome blocking system
Blockiersystem BERNARD Syndesmotome
BERNARD syndesmotomos sistema de bloqueo

Kit 1 manche + 5 Lames
1 handle + 5 blades kit
1 Griff + 5 Einsätze, Set
1 mango + 5 puntas
159.K



Lames interchangeables
Interchangeable blades
Auswechselbare Einsätze
Puntas intercambiables

Ref.	€ HT
157.01	84,66
157.02	84,66
157.03	84,66
157.04	84,66
157.05	84,66
157.06	84,66
159.52F	23,18
159.54F	23,18
159.55F	23,18
159.56F	23,18
159.60F	23,18
159.K	142,05
159.M	58,99

BARRY

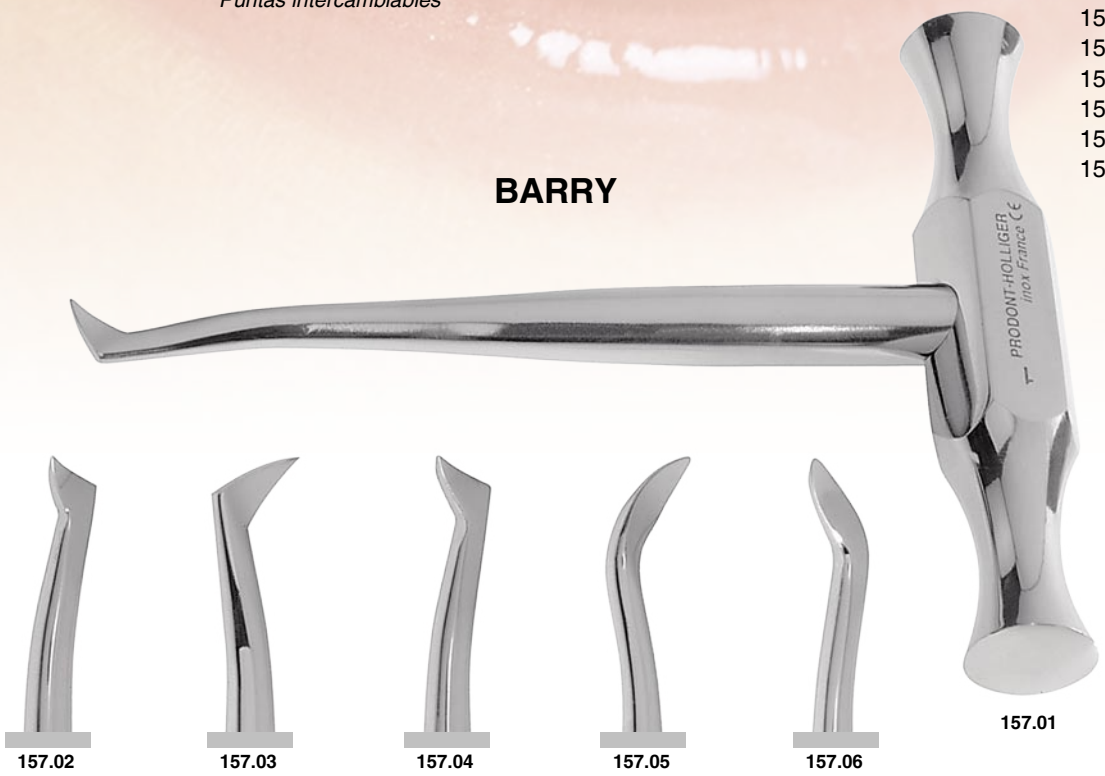

Les élévateurs de KOPP présentent un tranchant hélicoïdal qui épouse la forme de la racine et coupe le périodonte. La coupe se produit naturellement avec un mouvement apical.

EXTRACTION



Sens Gauche / Left / Links / Izquierdo



156.40

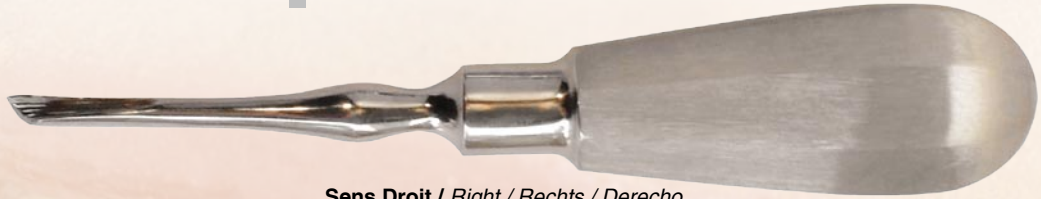

Sens Droit / Right / Rechts / Derecho



156.41

Idéal en rotation autour d'une racine
Perfect for rotating around the root

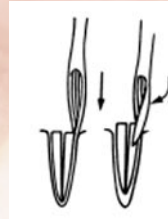

The KOPP elevators have a sharp edged helical groove that follows the root tip down and around cutting the ligament. There is a natural cutting action as the elevator moves apically.

Die Wurzelheber «Kopp» haben ein scharfes spiralförmiges Arbeitsende, dass sich der Form der Wurzel anpasst und periodontale Bänder schneidet. Der Schnitt vollzieht sich auf natürliche Weise mit einer apikalen Bewegung.

Los elevadores de KOPP presentan una lama helicoidal que se adapta a la raíz y corta el periodonto. El corte se lleva a cabo naturalmente con un movimiento apical.

Ref.	€ HT
156.40	55,70
156.41	55,70

Elévateurs Luxateurs
Elevators luxators- Wurzelheber - Elevadores

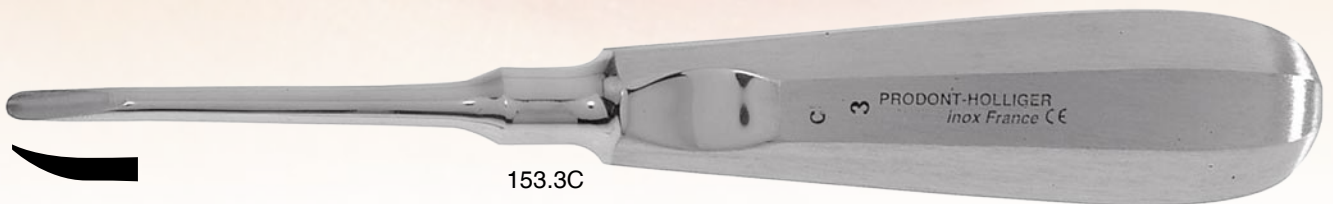

153.3C

Ref.	€ HT
159.3C	64,40
159.5C	60,05
159.3D	64,40
159.5D	60,05



159.3D



159.5C



159.5D

BEIN

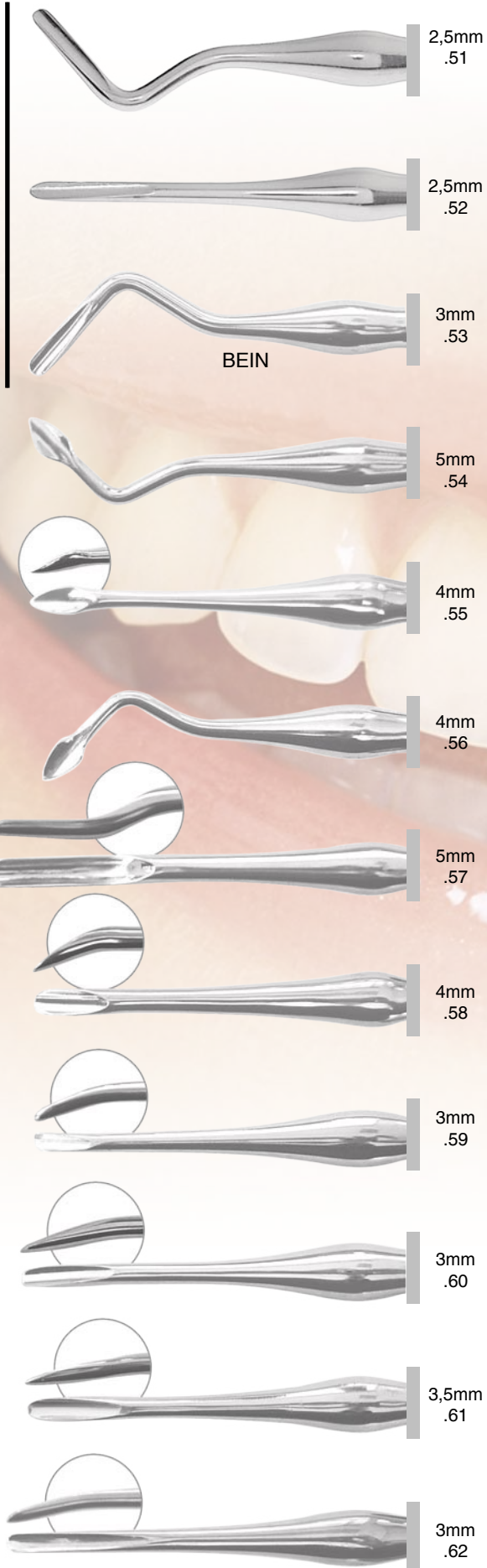

Choisissez votre manche!
Choose your handle!

WHITE APICAL

3mm



156.50

Manche léger standard

Standard light handle
Leichter Standard Griff
Mango ligero estándar



159.50

Manche léger avec appuie-doigts

Ergonomic light handle
Leichter ergonomischer Griff
Mango ligero con reposadores

Ref.	€HT	Ref.	€HT
156.50	55,70	159.50	68,75
156.51			
156.52			
156.53			
156.54			
156.55			
156.56			
156.57			
156.58			
156.59			
156.60			
156.61			
156.62			

Choisissez votre manche!
Choose your handle!



Manche léger standard
Standard light handle
Leichter Standard Griff
Mango ligero estándar

Ref.	€HT
156.63	60,05
156.64	60,05
156.65	55,70
156.66	55,70
156.67	55,70
156.68	55,70
156.69	60,05
156.70	55,70
156.71	55,70
156.72	55,70
156.73	55,70
156.74	55,70
156.75	55,70
156.76	60,05
156.77	60,05
156.78	60,05

Manche léger avec appui-doigts
Ergonomic light handle
Leichter ergonomischer Griff
Mango ligero con reposadores

Ref.	€HT
159.63	64,80
159.64	64,80
159.65	64,80
159.66	64,80
159.67	64,80
159.68	64,80
159.69	64,80
159.70	64,80
159.71	64,80
159.72	64,80
159.73	64,80
159.74	64,80
159.75	64,80
159.76	64,80
159.77	64,80
159.78	64,80

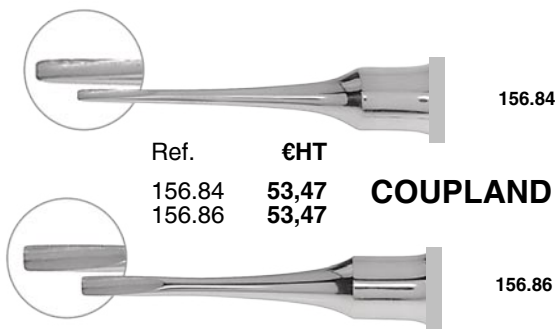

Ref.	€HT
156.84	53,47
156.86	53,47

COUPLAND

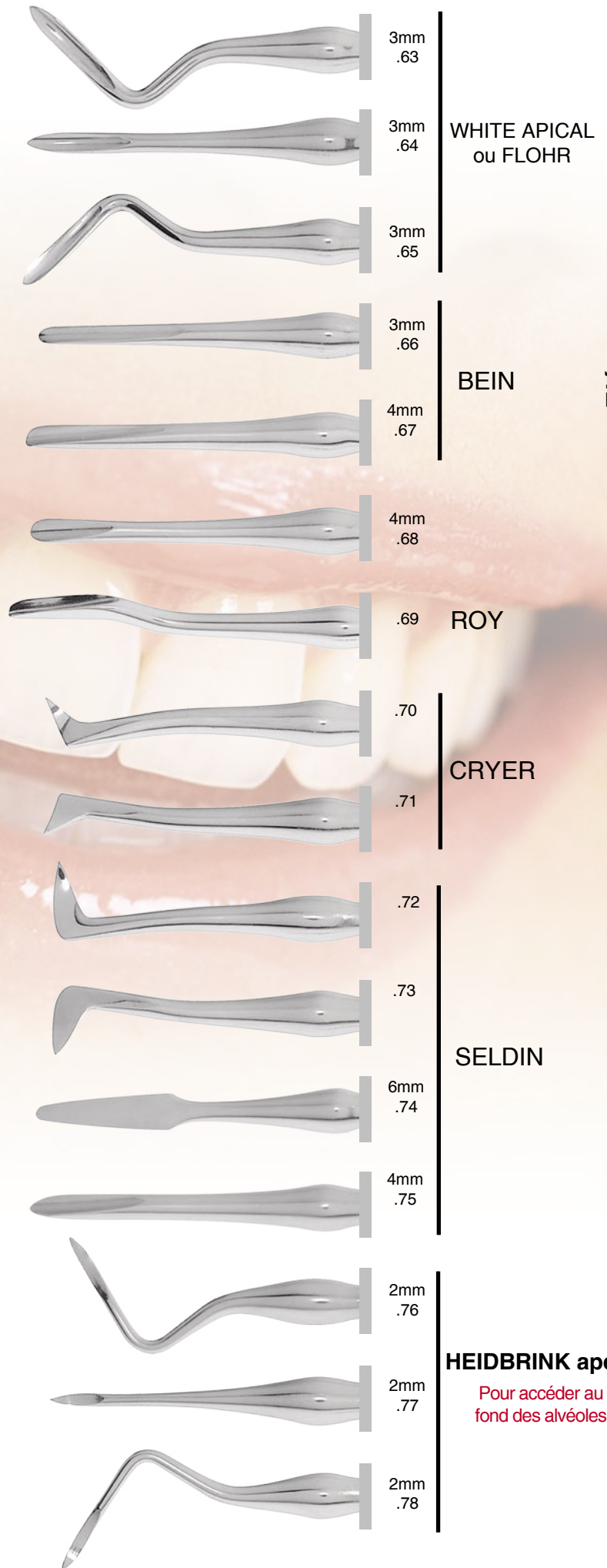

3mm
.63

3mm
.64

3mm
.65

3mm
.66

4mm
.67

4mm
.68

.69

.70

.71

.72

.73

6mm
.74

4mm
.75

2mm
.76

2mm
.77

2mm
.78

WHITE APICAL
ou FLOHR

BEIN

ROY

CRYER

SELDIN

HEIDBRINK apex

Pour accéder au
fond des alvéoles

EXTRACTION

Elévateurs
Elevators - Wurzelheber - Elevadores



VIGNAL lancette



VIGNAL lancette
€HT
L'élevateur 75,32



149.01
Manche Standard

VIGNAL

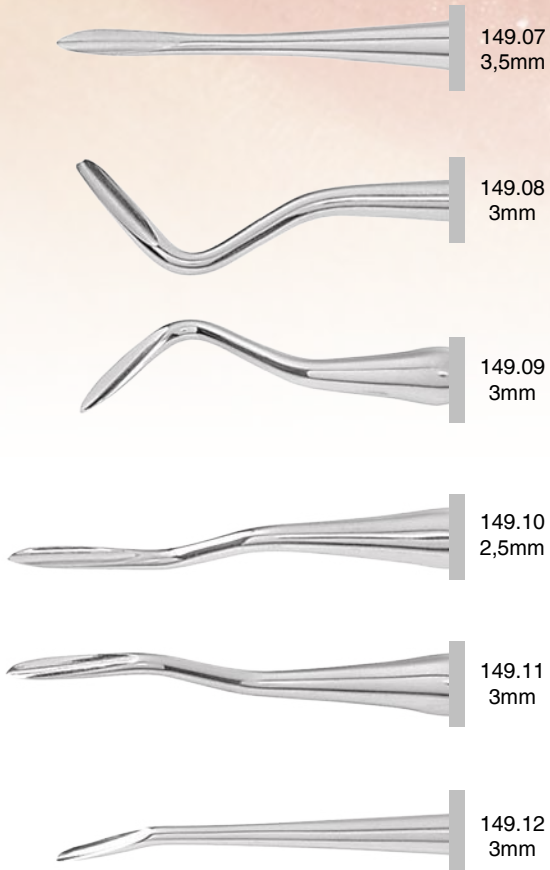

VIGNAL
€HT
L'élevateur 64,40

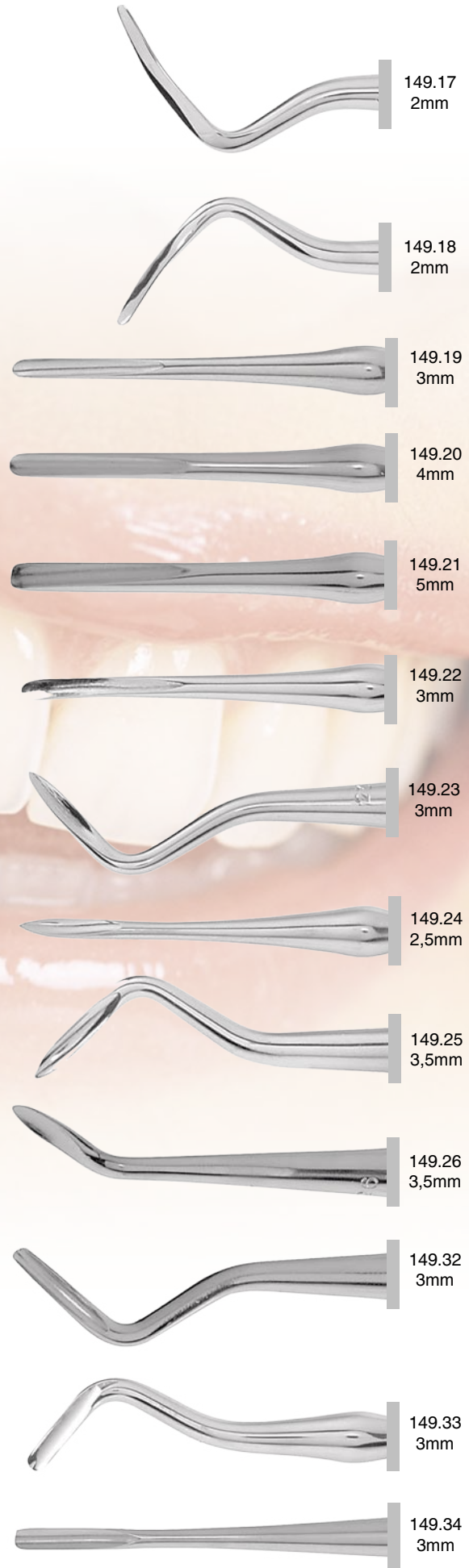
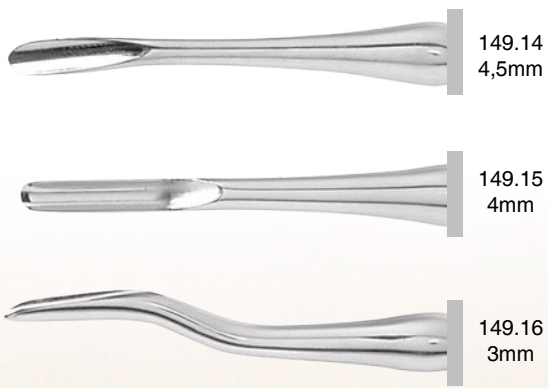

149.13
3mm

VIGNAL
L'élevateur €HT **64,40**

EXTRACTION

Elévateurs VIGNAL
Elevators - Wurzelheber - Elevadores

DAVIERS rétentifs (adulte)

Forceps super-grip beak - Haftprofil-Zahnzangen - Avulsión dental, adultos

EXTRACTION

Daviers rétentifs (adulte)
Forceps super-grip beak - Haftprofil-Zahnzangen - Avulsión dental, adultos



290.01

Incisives centrales et canines supérieures
Upper centrals and canines
Obere, mittlere Schneide- und Eckzähne
Incisivos centrales y caninos superiores



290.02

Incisives et canines supérieures
Upper incisors and canines
Obere Schneide- und Eckzähne
Incisivos y caninos superiores



290.04

Incisives et canines inférieures
Lower incisors and canines
Untere Schneide- und Eckzähne
Incisivos y caninos inferiores



290.07

Prémolaires supérieures
Upper bicuspid
Obere Bicuspidaten
Premolares superiores



290.08

Prémolaires inférieures
Lower bicuspid
Untere Prämolaren
Premolares inferiores



290.13

Canines et prémolaires inférieures
Lower canines and bicuspid
Untere Eckzähne und Prämolaren
Caninos y premolares inferiores



290.17

Molaires supérieures droites
Upper right molars
Obere Molaren, rechts
Molares superiores, lado derecho

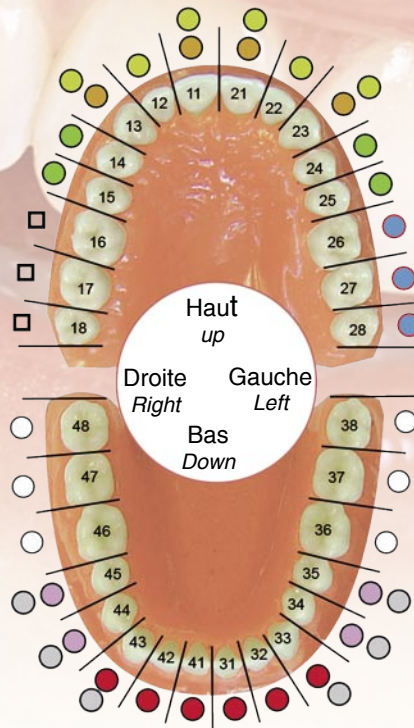

290.18

Molaires supérieures gauches
Upper left molars
Obere Molaren, links
Molares superiores, lado izquierdo



290.21

Molaires inférieures
Lower molars
Untere Molaren
Molares inferiores

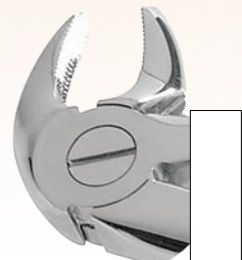

290.22
Molaires inférieures
Lower molars - Untere Molaren
Molares inferiores



290.73
Molaires inférieures
Lower molars
Untere Molaren
Molares inferiores

Satinés
Satin-like finish
Satiniert
Acabo satinado

Standards

Ref.	€HT
290.01	87,95
290.02	
290.04	
290.07	
290.08	
290.13	
290.17	
290.18	
290.21	
290.22	
290.73	
290.75	



Ref.	€HT
1290.01	92,30
1290.02	
1290.04	
1290.07	
1290.08	
1290.13	
1290.17	
1290.18	
1290.21	
1290.22	
1290.73	
1290.75	

€HT 92,30



290.75
Canines et prémolaires inférieures
Lower canines and bicuspid
Untere Eckzähne und Prämolaren
Caninos y premolares inferiores

DAVIERS rétentifs (adulte)

Forceps super-grip beak - Haftprofil-Zahnzangen - Avulsión dental, adultos



290.23

Davier forme syndesmotome du bas
 Syndesmotome lower roots
 Zahnzange, Syndesmotom-Maulteile, untere Wurzeln
 Forceps, picos Syndesmotomos, raices inferiores



Profil lanosolé



290.24 Davier forme syndesmotome du haut

Syndesmotome upper model / Syndesmotom-Maulteile, obere Wurzeln
 Forceps, picos Syndesmotomos, raices superiores



290.25

Davier forme syndesmotome du bas
 Syndesmotome lower model forceps
 Syndesmotom-Maulteile, untere Wurzeln
 Forceps, picos Syndesmotomos, raices inferiores



290.33

Racines inférieures
 Lower roots
 Untere Wurzeln
 Raices inferiores



290.51

Racines supérieures
 Upper roots
 Obere Wurzeln
 Raices superiores



290.79

Dents de sagesse inférieures
 Lower wisdoms
 Untere Weisheitszähne
 Cordales inferiores

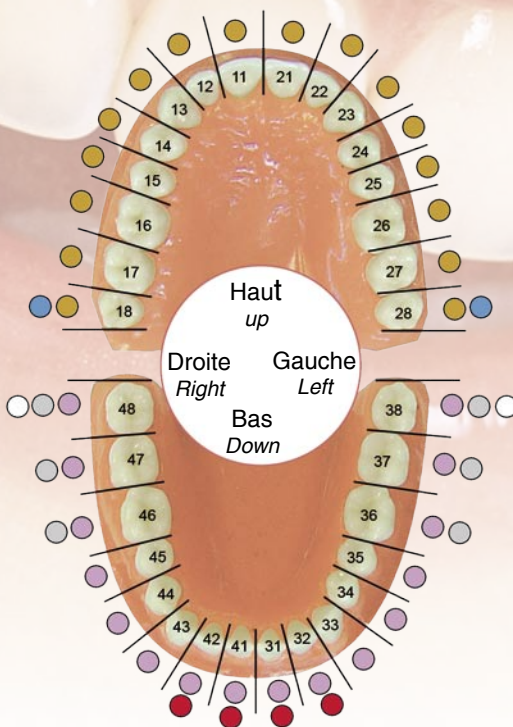

291.60

Racines supérieures, mors extra fins
 Upper roots, extra slim jaws
 Obere Wurzeln, extra Schlankes Maul
 Raices superiores, medio, bocado extra fino



291.51

Racines supérieures
 Upper roots
 Obere Wurzeln
 Raices superiores



291.61

Racines supérieures, court, mors extra fins
 Upper roots, short, extra slim jaws
 Obere Wurzeln, kurzes, extra schlankes Maul
 Raices superiores, corto, bocado extra fino



291.62

Racines supérieures, mors extra fins
 Upper roots, extra slim jaws
 Obere Wurzeln, langes, extra schlankes Maul
 Raices superiores, largo, bocado extra fino



291.67

Dents de sagesse supérieures, 2 côtés
 Upper wisdoms, either sides
 Obere Weisheitszähne
 Cordales superiores



291.74

Racines et incisives inférieures
 Lower roots and incisors
 Untere Wurzeln und Schneidezähne
 Raices e incisivos inferiores

Standards

Ref	€HT	Ref	€HT
290.33	87,95	1290.33	92,30
290.51	87,95	1290.51	92,30
290.79	87,95	1290.79	92,30
291.51	87,95	1291.51	92,30
291.60	87,95	1291.60	92,30
291.61	87,95	1291.61	92,30
291.62	87,95	1291.62	92,30
291.67	87,95	1291.67	92,30
291.74	87,95	1291.74	92,30
291.86	87,95	1291.86	92,30
290.23	98,88		
290.24	98,88		
290.25	98,88		

Satinés

Satin-like finish
 Satiniert
 Acabo satinado



291.86

Molaires inférieures cariées, découronnées
 Lower molars decayed or with broken down crown
 Untere Molaren, kariöse, abgebrochene Kronen
 Molares inferiores, cariados, coronas dañadas

EXTRACTION

Daviers rétentifs (adulte)

Forceps super-grip beak - Haftprofil-Zahnzangen - Avulsión dental, adultos

DAVIERS KLEIN rétentifs (enfant)

Child Forceps super-grip beak - Kinder Haftprofil-Zahnzangen - Avulsión dental, niños

EXTRACTION

Daviers KLEIN rétentifs (enfant)
Child Forceps super-grip beak - Kinder Haftprofil-Zahnzangen - Avulsión dental, niños



295.01

Incisives supérieures, ressort
Upper incisors, with spring
Obere Schneidezähne, Feder
Incisivos superiores con resorte

Avec ressort
With spring
Mit Feder
Con resorte



296.01

Incisives supérieures, sans ressort
Upper incisors, without spring
Obere Schneidezähne, Ohne Feder
Incisivos superiores, sin resorte

Sans ressort
Without spring
Ohne Feder
Sin resorte



295.02 / 296.02

Prémolaires supérieures
Upper premolars
Obere Prämolaren
Premolares superiores



295.03 / 296.03

Racines supérieures
Upper roots
Obere Wurzeln
Raíces superiores



295.04 / 296.04

Molaires supérieures
Upper molars
Obere Molaren
Molares superiores



295.05 / 296.05

Incisives inférieures
Lower incisors
Untere Schneidezähne
Incisivos inferiores



295.06 / 296.06

Molaires inférieures
Lower molars
Untere Molaren
Molares inferiores



295.07 / 296.07

Racines inférieures
Lower roots
Untere Wurzeln
Raíces inferiores

€HT

L'élevateur 114,68

DAVIERS standards (enfant)
Child Forceps - Kinder Zahnzangen - forceps para niños

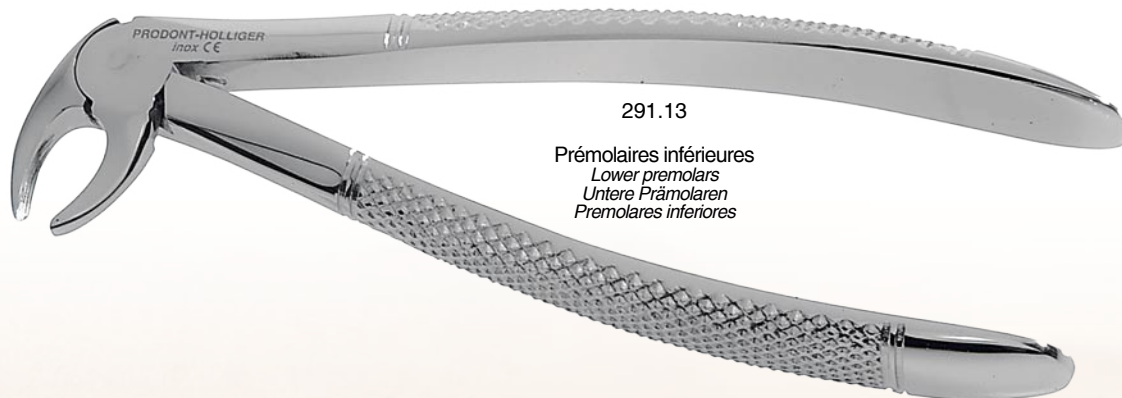

291.13

Prémolaires inférieures
Lower premolars
Untere Prämolaren
Premolares inferiores



291.22

Molaires inférieures
Lower molars
Untere Molaren
Molares inferiores

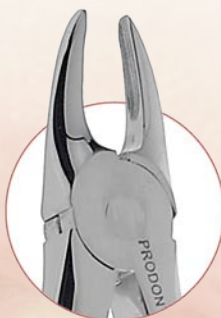

291.29

Racines supérieures
Upper roots
Obere Wurzeln
Raíces superiores



291.33

Racines inférieures
Lower roots
Untere Wurzeln
Raíces inferiores

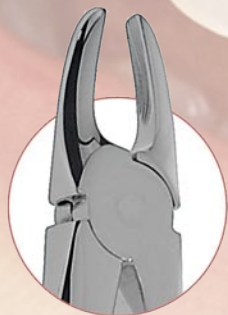

291.37

Incisives supérieures
Upper incisors
Obere Schneidezähne
Incisivos superiores



291.38

Incisives et canines inférieures
Lower incisors and canines
Untere Schneide- und Eckzähne
Incisivos y caninos inferiores

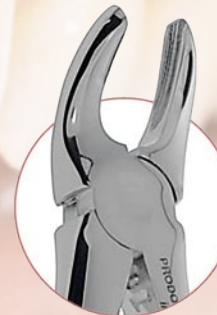

291.39

Molaires supérieures
Upper molars
Obere Molaren
Molares superiores

€HT

Le davier 111,39

SETS de DAVIERS
Sets - Estuche

10 Daviers Standards
10 Standard forceps
10 standard Zahnzangen
10 Forceps estándar

Ref.	€HT
290.00	874,18
Contenu	
290.02	
290.07	
290.17	
290.18	
291.67	
291.51	
290.13	
290.22	
290.33	
290.79	

10 daviers Satinés
10 Satin-like finish forceps
10 satinierte Zahnzangen
10 Forceps, acabado satinado

Ref.	€HT
1290.00	917,89
Contenu	
1290.02	
1290.07	
1290.17	
1290.18	
1291.67	
1291.51	
1290.13	
1290.22	
1290.33	
1290.79	

EXTRACTION

Daviers standards (enfant)
Child Forceps - Kinder Zahnzangen - forceps para niños

CHOMPRET

Après extraction, le curetage de l'alvéole permet de retirer les tissus infectés et fait revenir le sang pour coagulation et ostéogénèse.



manche **XL Style** handle 134.01XL



manche **Design** handle 134.01D

After extraction, the sharp spoon withdraws infected tissues for coagulation and osteogenesis.



134.02XL
134.02D

Nach der Extraktion, die Kürettage der Alveole erlaubt infiziertes Gewebe zu entfernen, die Rückkehr des Blutes für Koagulation und Osteogenesis.



134.03XL
134.03D

Después del extracción, el curetaje alveolar permite de retirar los tejidos infectados y favorece la coagulación y osteogénesis.



134.04XL
134.04D



134.05XL
134.05D

XL Style

Ref.	€ HT
131.01XL	35,96
131.02XL	35,96
131.03XL	35,96
134.01XL	42,54
134.02XL	42,54
134.03XL	42,54
134.04XL	42,54
134.05XL	42,54

Granulation



131.01XL
131.01D



131.02XL
131.02D



131.03XL
131.03D

Design

Ref.	€ HT
131.01D	29,90
131.02D	29,90
131.03D	29,90
134.01D	31,61
134.02D	31,61
134.03D	31,61
134.04D	31,61
134.05D	31,61

CURETTES TRANCHANTES et Pince LUER FRIEDMANN
 Sharp spoons - Scharfe Löffel - Curetas cortantes

HEMINGWAY



manche XL Style handle



manche Design handle

XL Style

Ref.	€ HT
135.00XL	55,70
135.01XL	55,70
135.02XL	55,70
135.03XL	55,70
135.85XL	46,89
135.86XL	46,89

Design

Ref.	€ HT
135.00D	46,89
135.01D	46,89
135.02D	46,89
135.03D	46,89
135.85D	33,85
135.86D	33,85

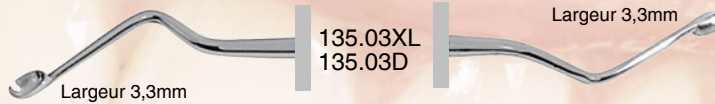
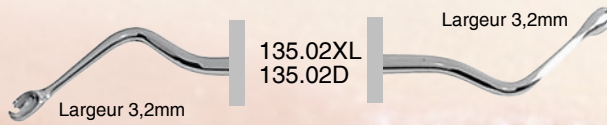

LUCAS

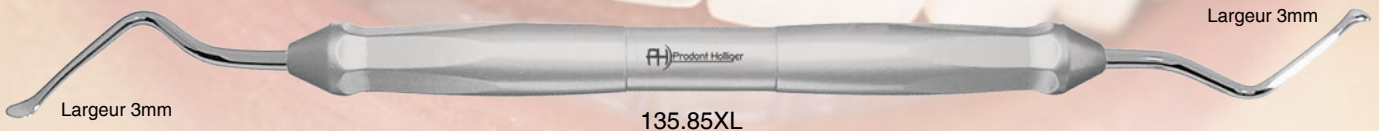

Pince gouge LUER FRIEDMANN
Mors Fins
Fine

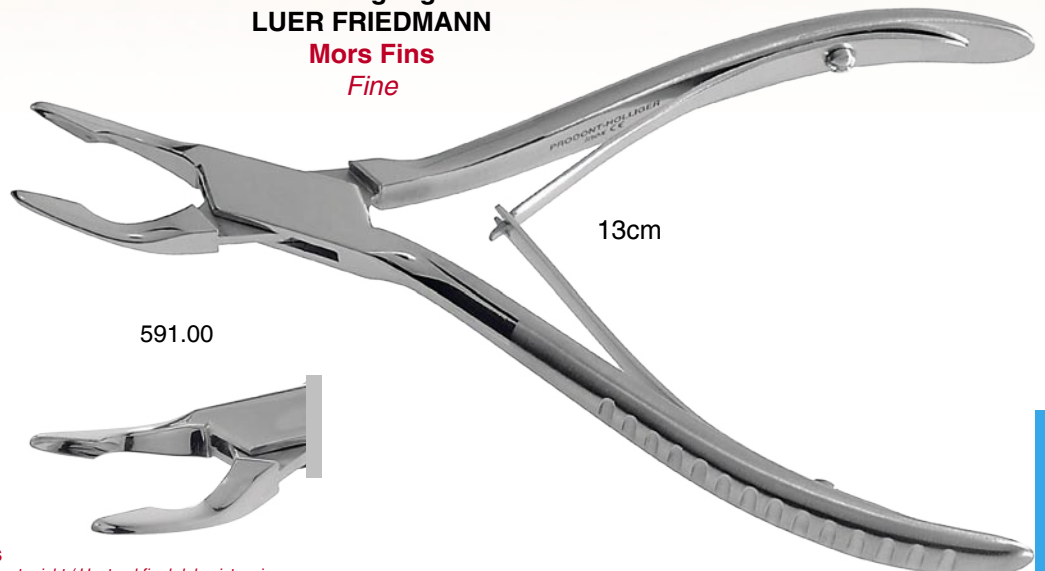

Ref.	€ HT
591.00	125,61

591.00

■ Jusqu'à épuisement des stocks
 Until the end of stocks / So langer der Vorrat reicht / Hasta el final del existencia

EXTRACTION

Curettes Tranchantes
 Sharp spoons - Scharfe Löffel - Curetas cortantes

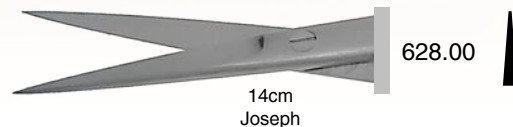
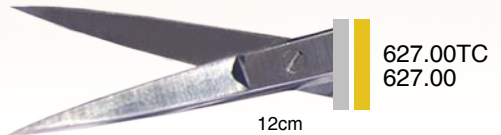
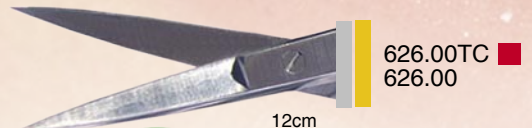

TC:
CARBURE DE TUNGSTÈNE:
RÉSISTANCE A L'USURE
QUALITÉ DE COUPE PRÉSERVÉE

Tungsten carbide / Tungsten Karbid
Carburo de tungsteno

Tranchant & Longévité
Sharpness & longevity
erhält die Schärfe
Conserva el filo



Ref.	€ HT
620.01	23,45
620.01TC	67,15
621.00	20,69
621.00TC	67,15
622.00	20,69
622.00TC	67,15
623.00	20,69
623.00TC	67,15
624.00	20,69
625.00	20,69
626.00	31,61
626.00TC	75,32
627.00	31,61
627.00TC	75,32
628.00	42,54
629.00	42,54
630.00	42,54

Jusqu'à épuisement des stocks
Until the end of stocks / So langer der Vorrat reicht / Hasta el final del existencia

Mors droits
Straight / Gerade / Recto

Mors courbes
Curved / Gebogen / Curvado

Lames Carbure de Tungstène (TC)

Tungsten carbide
Tungsten Carbide
Carburo de tungsteno

*Tranchant & Longévité
Sharpness & longevity
erhält die Schärfe
Conserva el filo*

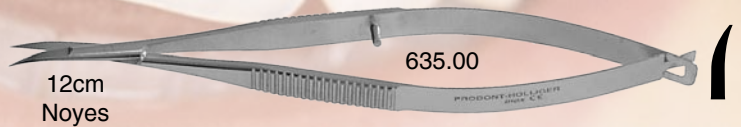
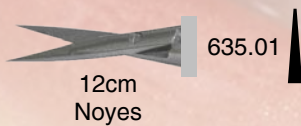
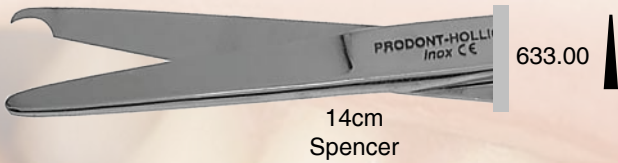

Ref.	€ HT
631.00	42,54
632.00	42,54
633.00	23,98
634.00	42,54
635.00	64,40
635.01	66,62
636.00	53,47
636.00TC	75,32
647.01TC	166,03
647.02TC	166,03
651.00	13,90
651.00TC	75,32
652.00	15,90
652.00TC	75,32

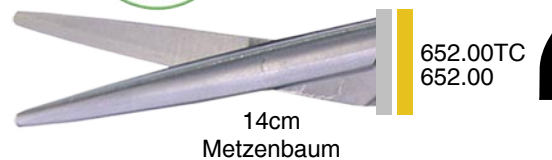
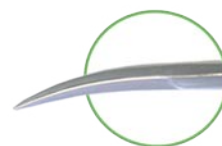
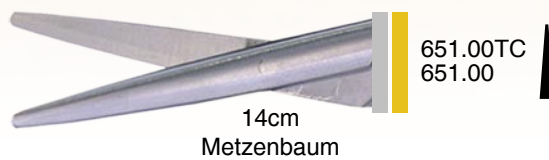

Jusqu'à épuisement des stocks
Until the end of stocks / So langer der Vorrat reicht / Hasta el final del existencia

Mors droits
Straight / Gerade / Recto

Mors courbes
Curved / Gebogen / Curvado

CHIRURGIE

Ciseaux
scissors - Scheren - Tijeras

Ciseaux
scissors - Scheren - Tijeras

CHIRURGIE

Ciseaux
scissors - Scheren - Tijeras

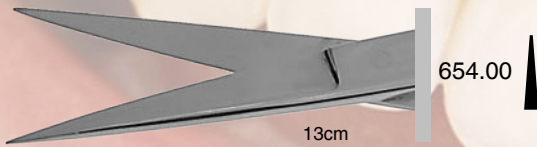

*Tranchant & Longévité
Sharpness & longevity
erhält die Schärfe
Conserva el filo*

Lames Carbone de Tungstène (TC)
Tungsten carbide
Tungsten Carbide
Carburo de tungsteno

Ref.	€ HT
653.00	14,75
653.01	20,69
654.00	14,25
654.01TC	67,15
655.00	13,26
655.01TC	67,15
656.00	11,14
659.00	11,14

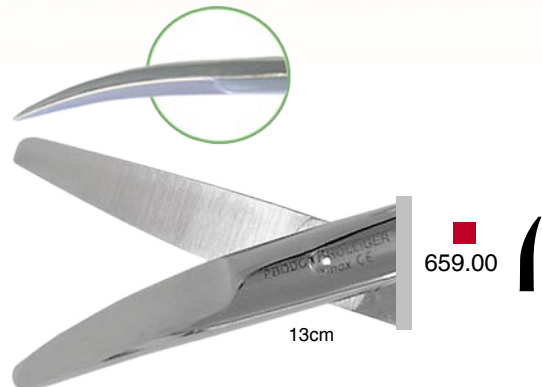
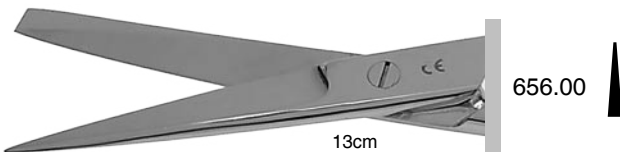
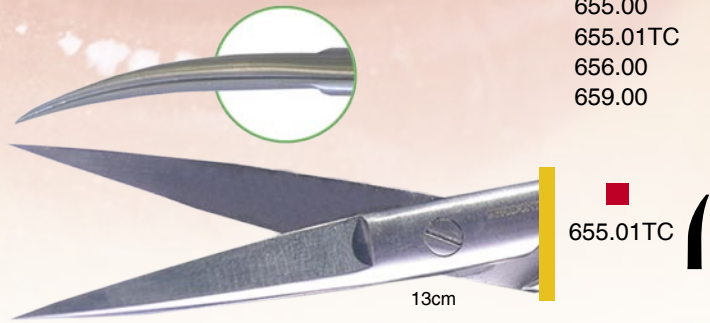
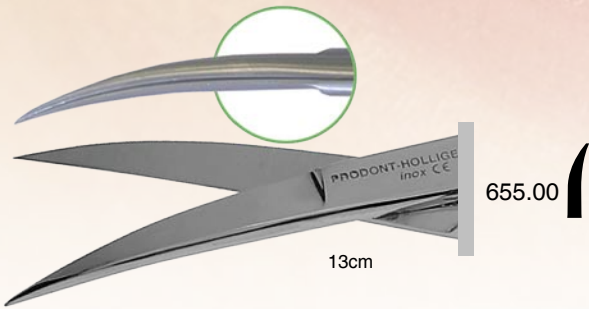

▲ Mors droits
Straight / Gerade / Recto

◄ Mors courbes
Curved / Gebogen / Curvado

■ Jusqu'à épuisement des stocks
Until the end of stocks / So langer der Vorrat reicht / Hasta el final del existencia

Précelles à tissu ADSON
Tweezers - Pinzetten - Pinzas



222.10

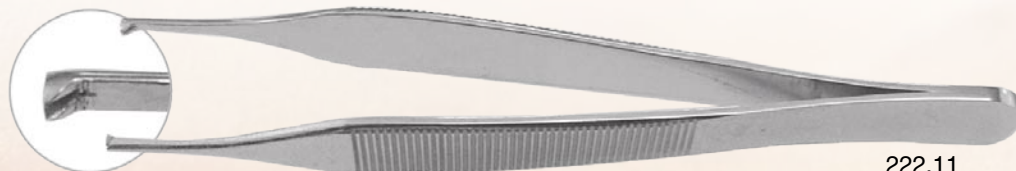

222.11

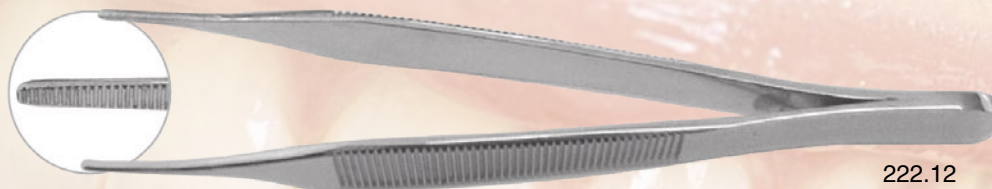

222.12

Précelles à marquer et suturer
Tweezers - Pinzetten - Pinzas

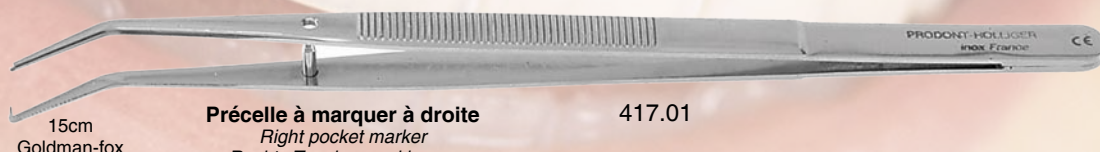

15cm
Goldman-fox

Précelle à marquer à droite
Right pocket marker
Rechts Taschenmarkierung
Pinza para marcar derecho

417.01



15cm
Goldman-fox

Précelle à marquer à gauche
Left pocket marker
Links Taschenmarkierung
Pinza para marcar izquierdo

417.02



15cm

Précelle à suture, oeillets fermés
Suture tweezers

428.00

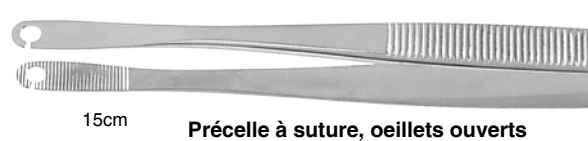

15cm

Précelle à suture, oeillets ouverts
Suture tweezers

429.00



15cm
CORN

Précelle à suture
Suture tweezers

432.00

Ref.	€ HT
222.10	14,43
222.11	14,43
222.12	14,43
417.01	19,52
417.02	19,52
428.00	20,79
429.00	20,79
432.00	30,34

Précelles à tissus
Tweezers - Pinzetten - Pinzas

CHIRURGIE

Précelles
Tweezers - Pinzetten - Pinzas

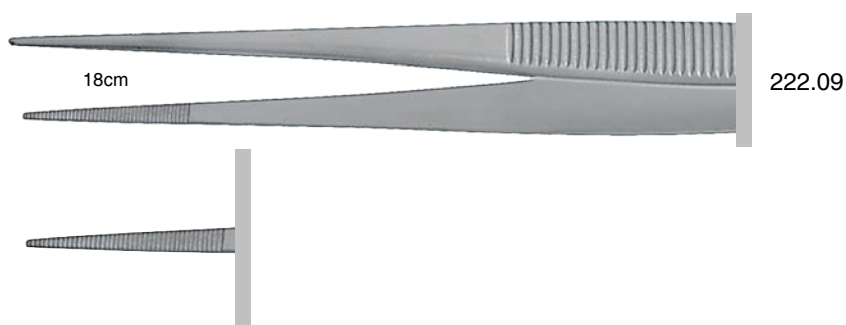
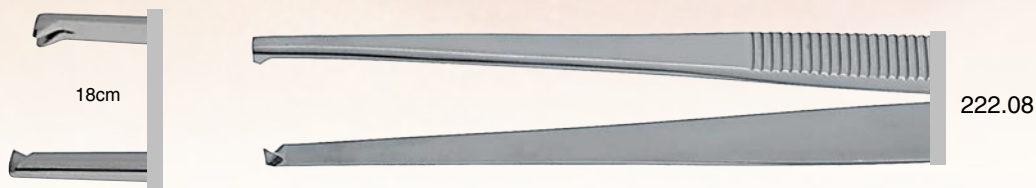
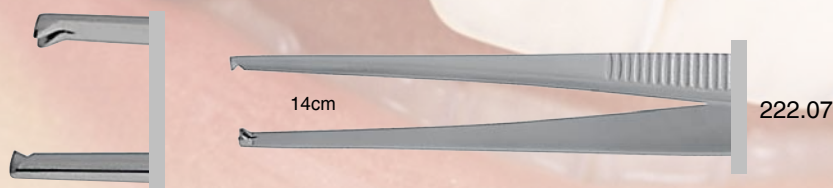
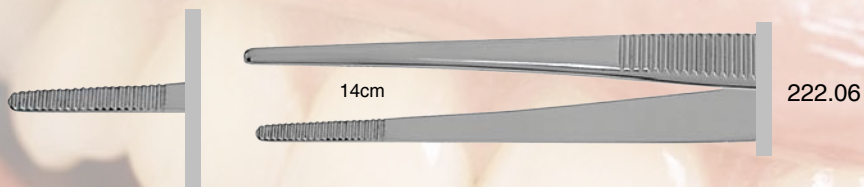
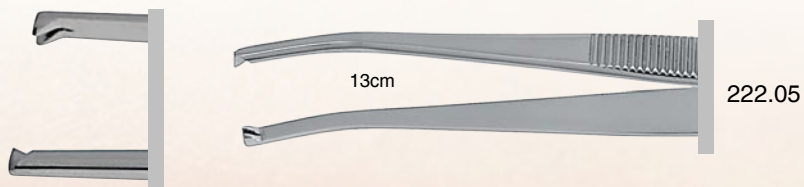

Ref.	€ HT
222.04	15,17
222.05	15,17
222.06	15,17
222.07	19,52
222.08	19,52
222.09	19,52

MOSQUITO



Mors courbes et fins 724.01
 Curved / Gebogen / Curvado

HALSTEAD-MOSQUITO

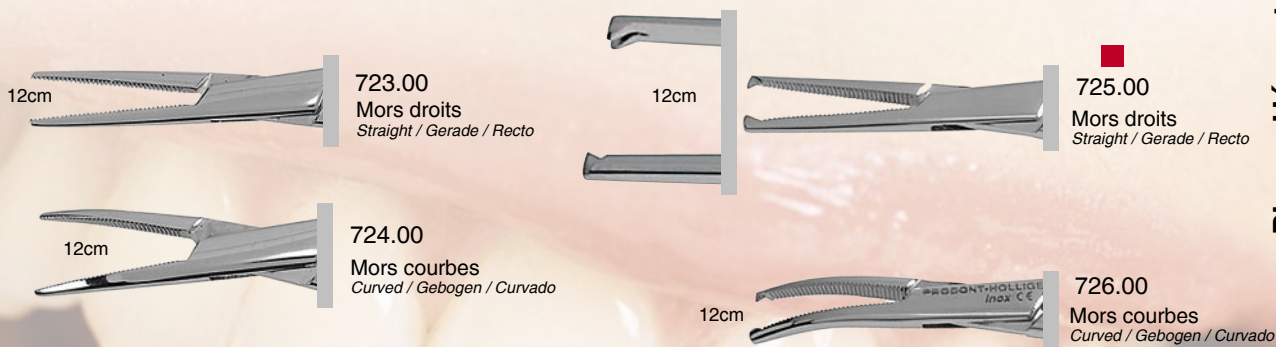

12cm 723.00
 Mors droits
 Straight / Gerade / Recto

12cm 725.00
 Mors droits
 Straight / Gerade / Recto

12cm 724.00
 Mors courbes
 Curved / Gebogen / Curvado

12cm 726.00
 Mors courbes
 Curved / Gebogen / Curvado

CRILLE



14cm 729.00
 Mors droits
 Straight / Gerade / Recto

14cm 730.00
 Mors courbes
 Curved / Gebogen / Curvado

PEAN

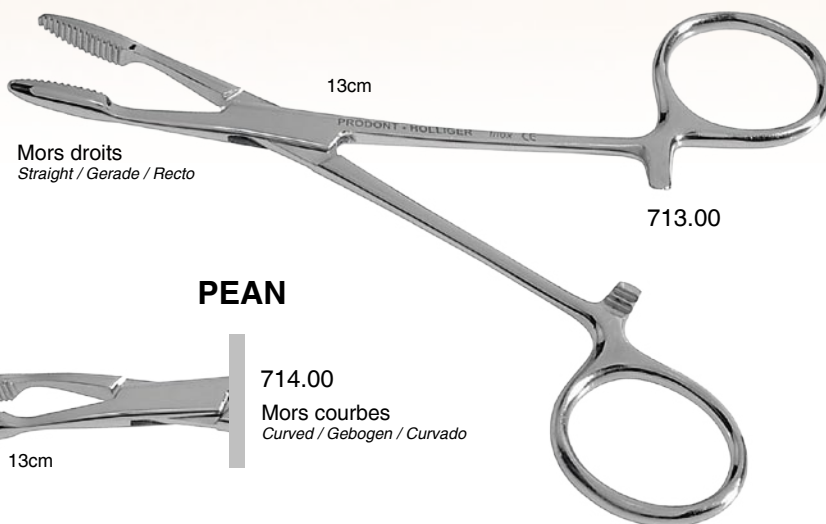

13cm 713.00
 Mors droits
 Straight / Gerade / Recto

13cm 714.00
 Mors courbes
 Curved / Gebogen / Curvado

Ref.	€ HT
713.00	17,40
723.00	17,40
724.00	17,40
724.01	19,63
725.00	17,40
726.00	17,40
729.00	19,10
730.00	19,10

Pinces Hémostatiques

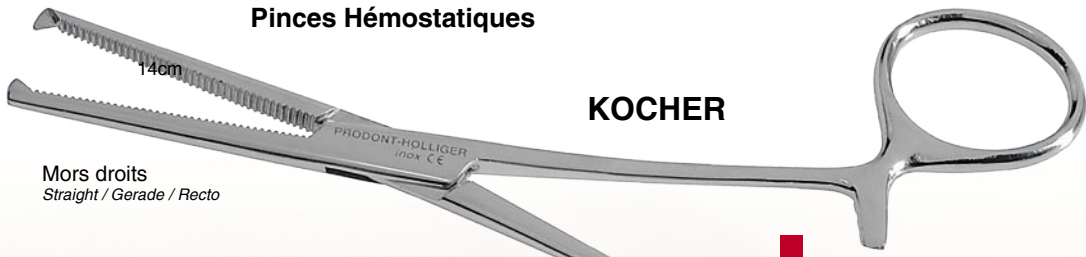

Mors droits
Straight / Gerade / Recto

KOCHER

731.00



Mors courbes
Curved / Gebogen / Curvado

KOCHER

732.00

Pinces à champs



BACKHAUS

708.00



707.00

**Pince gouge
LUER FRIEDMANN**

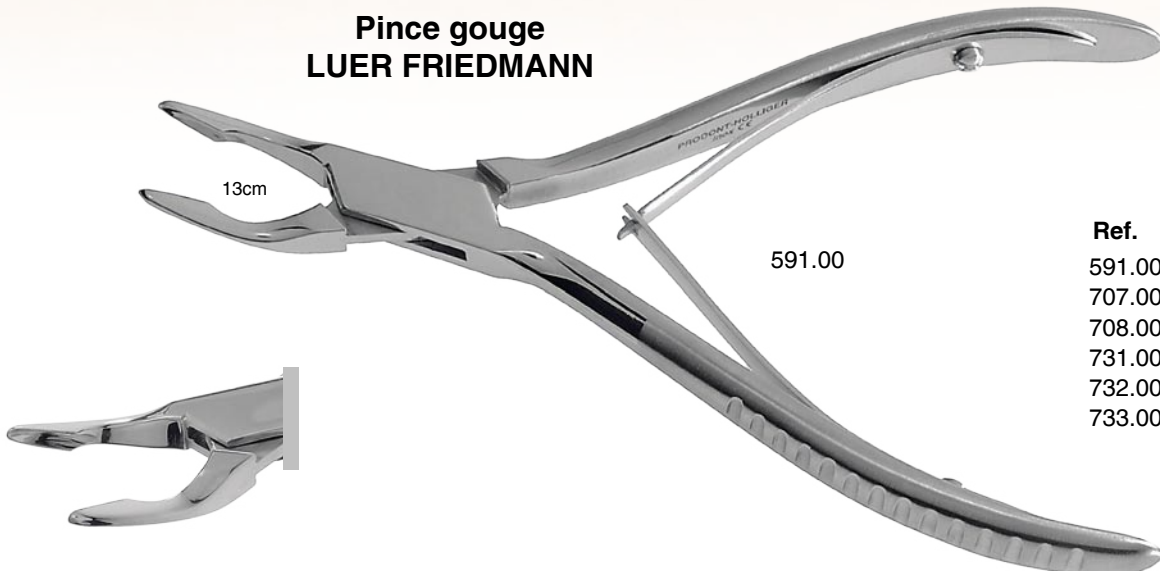

591.00

Ref.	€ HT
591.00	125,61
707.00	18,57
708.00	18,57
731.00	18,57
732.00	18,57
733.00	16,87

MATHIEU



TC

Mors Carbure de Tungstène: résistance à l'usure.
Tungsten carbide / Tungsten Carbid / Carburo de tungsteno



CASTROVIEJO

Ref.	€ HT
743.00	42,54
743.00TC	92,83
744.00	42,54
744.00TC	92,83
747.01TC	213,03
747.02TC	213,03
747.11 ■	119,03
747.11TC	184,60
747.12	119,03
747.12TC	184,60

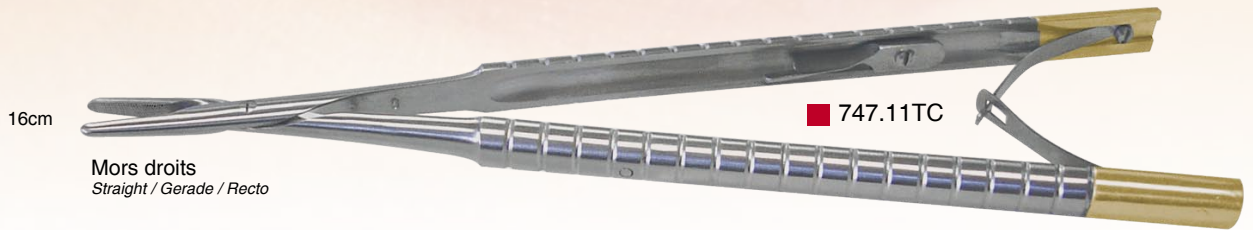

NOUVEAUTÉ
NEW

BARD PARKER: La Lame de Bistouri Sans Risque!
Risk-Free Scalpel system

CHIRURGIE



600.03



Manche de bistouri pour lame jetable stérile avec gaine de protection.
Scalpel handle for disposable sterile blade with plastic shield safety lock



La protection plastique évite tout risque de coupure pour placer et retirer la lame.
The plastic shield covers the blade when placing and removing it.



615.10

Lame stérile vendue à l'unité (séparément)
1x Sterile blade (sold separately)

Voir page 40 pour plus de détails
See page 40 for more details



610.00XL 12 cm

manche XL Style handle



601.03 n°3 12,5cm

Ref.	€ HT
600.03	95,90
601.03	15,28
615.10	4,90
615.11	39,25
615.15	39,25
610.00XL	38,30



615.11
Lames stériles
Sterile blades n°11
x100



615.15
Lames stériles
Sterile blades n°15
x100



Lames vendues séparément
Blades sold separately

Ciseaux à os
Bone chisels - Knochen Meißel - Cinceles para huesos



415.30

Le ciseau à os
 cambré €HT
 68,75



415.31

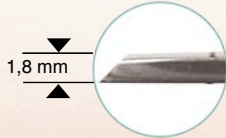

Biseau simple
Simple bevel / Einfache Abschrägung / Bisel simple

Le ciseau à os
 biseau simple €HT
 77,55



200.01
 4mm

415.10



200.02
 6mm

415.11



200.03
 8mm

415.12



Butées
Stop
Impulso

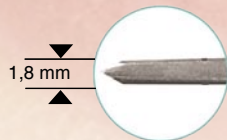

Biseau double
Double bevel / Doppelte Abschrägung / Bisel doble



200.01
 4mm

415.20



200.02
 6mm

415.21



200.03
 8mm

415.22

le ciseau à os
 biseau double €HT
 77,55

Ref. €HT
 213.02 119,03



Maillet Teflon 200g, 18cm
Hammer mit Teflonbacken - Martillo de teflón

Ecarteurs d'os
Bone splitters - Wundhaken - Separadores para huesos



Coins anguleux
Square corners
Gerade Ecken
Esquinas rectas

150.20
l. 3,5mm

l'écarteur d'os
 coins anguleux **€HT**
75,32



150.21
l. 5mm



150.22
l. 7mm

Manche avec poignée



Bone splitters with handle
Wundhaken mit Halter
Separadores con mango



Coins arrondis
Conic corners
Konische Ecken
Esquinas conicas

150.30
l. 2,3

l'écarteur d'os
 coins arrondis **€HT**
75,32



150.31
l. 3mm



150.32
l. 4mm

Ostéotomes droits convexes
Straight convex osteotomes
Osteotome, gerade, konvex - Osteótomos rectas

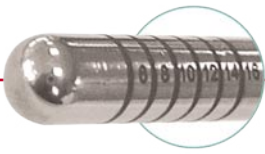

Marquage laser des millimètres sur 120°: lecture optimale
Laser marking on 120°: optimal reading
Lasermarkierung auf 120°: optimale Lektüre - Marcado laser sobre 120°: lectura óptima



353.11
Kit 5 ostéotomes
Set of 5 osteotomes
Set mit 5 Osteotomen
Estuche de 5 osteótomos

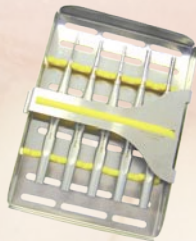

Cassette offerte
Free Tray
Kassette Gratis
Bandeja Gratis

Ref.	€ HT
353.01	57,82
353.02	57,82
353.03	57,82
353.04	60,47
353.05	60,47
353.11	293,87
354.01	57,82
354.02	57,82
354.03	57,82
354.04	60,47
354.05	60,47
354.11	293,87



Ostéotomes droits concaves
Straight concave osteotomes
Osteotome, gerade, konkav - Osteótomos rectas



354.11
Kit 5 ostéotomes
Set of 5 osteotomes
Set mit 5 Osteotomen
Estuche de 5 osteótomos



Cassette offerte
Free Tray
Kassette Gratis
Bandeja Gratis



Ostéotomes droits coniques convexes
Straight conic convex osteotomes
Osteotome, gerade, konisch konvex - Osteótomos rectas

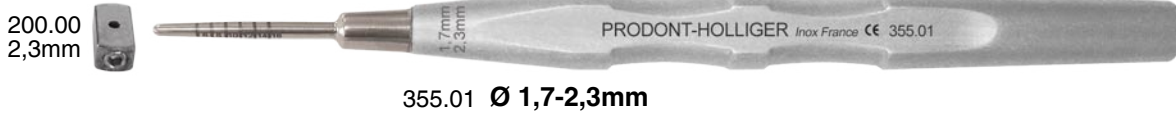
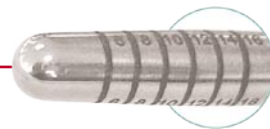

355.11
Kit 6 ostéotomes
Set of 6 osteotomes
Set mit 6 Osteotomen
Estuche de 6 osteótomos



Cassette offerte
Free Tray
Kassette Gratis
Bandeja Gratis

Ref.	€ HT
350.01	59,52
350.02	59,52
350.03	59,52
350.04	63,87
350.05	63,87
350.11	305,96
355.01	57,82
355.02	57,82
355.03	57,82
355.04	60,47
355.05	60,47
355.06	60,47
355.11	348,51

Ostéotomes angulés convexes
Angulated convex osteotomes
Osteotome, anguliert, konvex - Osteótomos arqueados



350.11
Kit 5 ostéotomes
Set of 5 osteotomes
Set mit 5 Osteotomen
Estuche de 5 osteótomos



Cassette offerte
Free Tray
Kassette Gratis
Bandeja Gratis

Ostéotomes angulés concaves

Angulated concave osteotomes
Osteotome, anguliert, konkav - Osteótomos arqueados

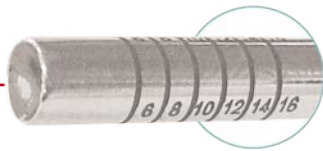

200.11
2,7mm



351.11

Kit 5 ostéotomes

Set of 5 osteotomes
Set mit 5 Osteotomen
Estuche de 5 osteótomos

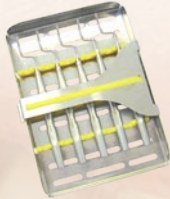

Cassette offerte

Free Tray
Kassette Gratis
Bandeja Gratis

Ref.	€ HT
351.01	59,52
351.02	59,52
351.03	59,52
351.04	63,87
351.05	63,87
351.11	305,96
352.01	59,52
352.02	59,52
352.03	59,52
352.04	63,87
352.05	63,87
352.06	63,87
352.11	370,36

200.12
3,2mm



200.13
3,7mm



200.14
4,2mm



200.15
5mm



351.01 Ø 2,7mm



351.02 Ø 3,2mm



351.03 Ø 3,7mm



351.04 Ø 4,2mm



351.05 Ø 5mm

Ostéotomes angulés coniques convexes

Angulated conic convex osteotomes
Osteotome, anguliert, konisch, konvex - Osteótomos arqueados



200.00
2,3mm



352.11

Kit 6 ostéotomes

Set of 6 osteotomes
Set mit 6 Osteotomen
Estuche de 6 osteótomos



Cassette offerte

Free Tray
Kassette Gratis
Bandeja Gratis

200.11
2,7mm



200.12
3,2mm



200.13
3,7mm



200.14
4,2mm



200.15
5mm



352.01 Ø 1,7-2,3mm



352.02 Ø 2,3-2,7mm



352.03 Ø 2,7-3,2mm



352.04 Ø 3,2-3,7mm



352.05 Ø 3,7-4,2mm



352.06 Ø 4,2-5mm

Accessoires
Accessories - Verschiedenes Zubehör - Accesorios

Butées pour ciseaux à os
Stop for bone chisels
Stop für Knochen Meißel
Impulso para cinceles para huesos



200.01
4mm

200.02
6mm

200.03
8mm

Butées pour ostéotomes
Stop for osteotomes
Stop für Osteotome
Impulso para osteótomos



200.00
Ø2,3mm

200.11
Ø2,7mm

200.12
Ø3,2mm

200.13
Ø3,7mm

200.14
Ø4,2mm

200.15
Ø5mm

Outil de serrage
Assembly tool

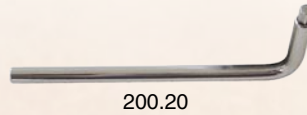

200.20

MAILLETS EMBOUTS TEFLON
Hammer mit Teflonbacken - Martillo de teflón



200g, 18cm

213.02

213.01

Ecarteurs
Retractors - Wundhaken - Separadores

Ref.	€ HT
151.00	27,16
151.01	40,42
151.02	40,42
200.00	9,23
200.01	18,04
200.02	18,04
200.03	18,04
200.11	9,23
200.12	9,23
200.13	9,23
200.14	9,23
200.15	9,23
200.20	9,23
213.01	129,96
213.02	119,03

151.00
FARABOEUF (2x)

12cm

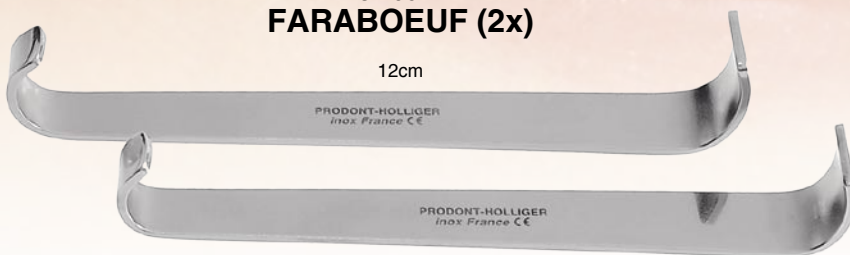

DAUTREY

151.02

151.01

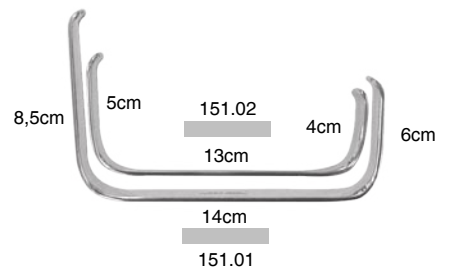

COMPAS DE PROFONDEUR

Depth compass / compás de profundidas



3336.00



3337.00

droit, 8cm

Straight compass / gerade / recto

Compas de CASTROVIEJO



3337.01

courbe, 8cm

Curved compass / gebogen / curvado

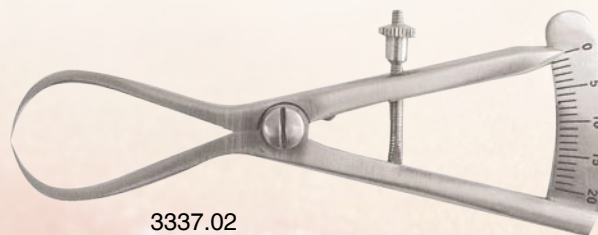

3337.02

arrondi, 8cm

Rounded compass / runde Figur / redondeado

Cupules INOX

Cubetas

Ref.	€ HT
3336.00	181,31
3337.00	133,25
3337.01	133,25
3337.02	133,25
380.00	6,68
380.01	7,32
380.02	7,96
380.03	8,91
380.04	11,25
380.05	12,52
380.06	16,34
390.00	55,70
395.00	64,40
395.01XL	49,50



Cuillère à os du Dr FALCON

**NOUVEAUTÉ
NEW**



395.01XL

Curette à os et mortier à os



390.00

28g, Ø4cm, H3,5cm



395.00

Râpes à os

Bone files - Knochenfeilen - rallador de huesos



manche **XLStyle** handle

4522.02XL

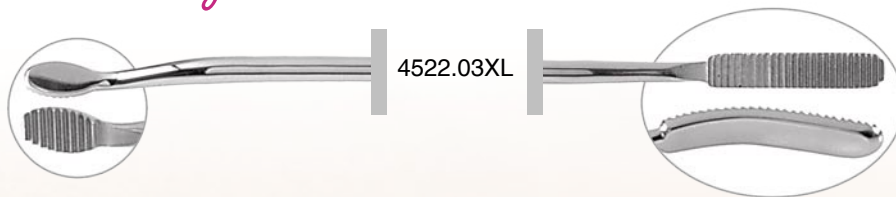

4522.03XL

XLStyle

Ref.	€ HT
4522.02XL	76,49
4522.03XL	76,49

Précelles ADSON

Tweezers - Pinzetten - Pinzas

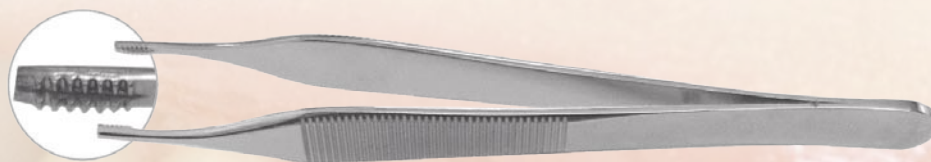

222.10



222.11

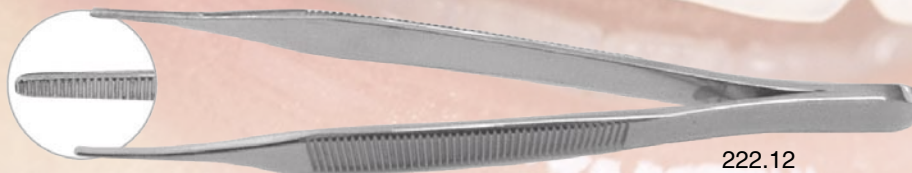

222.12

Ref.	€ HT
222.10	14,43
222.11	14,43
222.12	14,43

Ciseaux TC

Scissors - Scheren - Tijeras

11,5cm
Lagrange

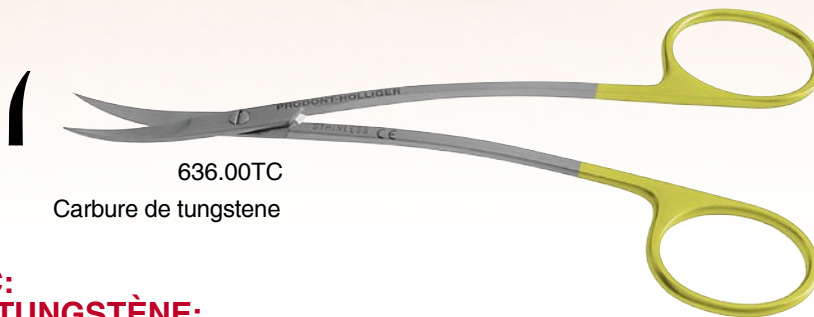

636.00TC

Carbure de tungstène

TC:
CARBURE DE TUNGSTÈNE:
RÉSISTANCE A L'USURE
QUALITÉ DE COUPE PRÉSERVÉE

Tungsten carbide / Tungsten Carbide / Carburó de tungsteno

Ref.	€ HT
636.00	53,47
636.00TC	75,32
651.00	13,90
651.00TC	75,32
652.00	15,90
652.00TC	75,32



14cm
Metzenbaum

651.00TC
651.00

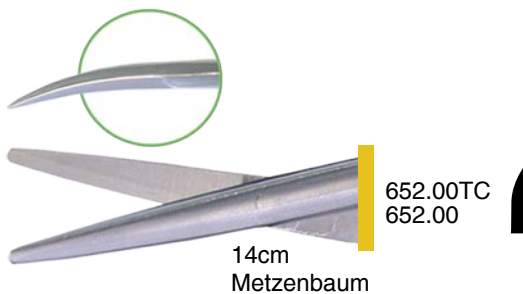

14cm
Metzenbaum

652.00TC
652.00

Porte-aiguille mors Carbure de tungstène
Needle holders - Nadelhalter - Porta agujas



747.01TC



747.02TC

TC

*Mors Carbure de Tungstène: résistance à l'usure.
Tungsten carbide / Tungsten Carbide / Carbu de tungsteno*

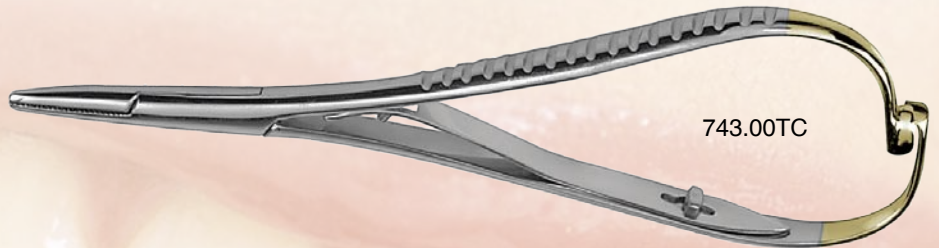

743.00TC



744.00TC

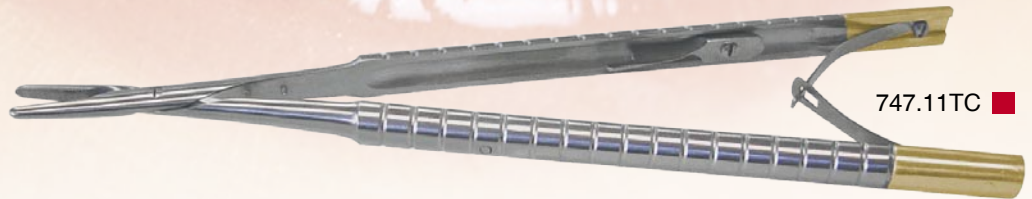

747.11TC ■



747.12TC

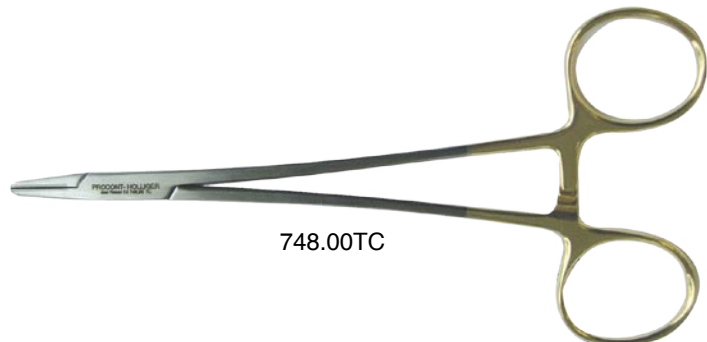

748.00TC

Ref.	€ HT
636.00	53,47
636.00TC	75,32
651.00	13,90
651.00TC	75,32
652.00	15,90
652.00TC	75,32
743.00	42,54
743.00TC	92,83
744.00	42,54
744.00TC	92,83
747.01TC	213,03
747.02TC	213,03
747.11 ■	119,03
747.11TC	184,60
747.12	119,03
747.12TC	184,60
748.00TC	103,76

■ Jusqu'à épuisement des stocks
Until the end of stocks / So lang er der Vorrat reicht / Hasta el final del existencia

NOUVEAUTÉ
NEW

DECOLLEUR DU Dr ROOS

Dr ROOS RETRACTOR



IMPLANTOLOGIE

3 en 1

Tous les avantages d'un décolleur, d'un écarteur et de la vision d'un excellent miroir!

UTILISATION

- Décoller les tissus mous.
- Rétracter et écarter avec appui osseux.
- Grâce au miroir intégré, contrôle visuel de l'acte chirurgical **pendant sa réalisation.**



manche
XL Style
handle



Mise en place d'implant avec contrôle de l'axe, forage et vissage.

Setting of implant with control of the axis while drilling and screwing.

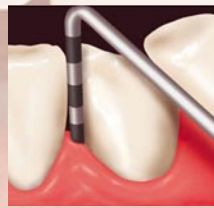

Contrôle de l'élimination du tartre et des défauts osseux dans le miroir.

Control of the elimination of the tartar and the osseous defects in the mirror.

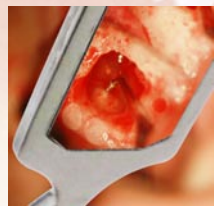

Contrôle de la résection apicale (opération d'un abcès sur l'extrémité de la racine de la dent) lors de chaque phase: décollement de la gencive, forage de l'os, section de la pointe de la racine, curetage de la cuvette osseuse, préparation et obturation du canal.

Control of the apical resection (removal of an abscess on the tip of the root) during every phase: Retraction of the gum, drilling of the bone, the section of the tip of the root, curettage of the osseous basin, the preparation and the closing of the canal.

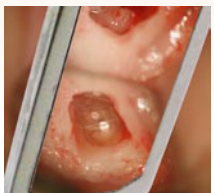

Photographie sous microscope ou à vue indirecte

Permet d'augmenter la profondeur de champ.

*Photography under microscope or at indirect sight
Increases depth of field.*



Ref. €HT
407.05XL 138,54

Elévateurs de sinus
Sinus lift - Sinuslift-Instrumente - elevador de Seno



XL Style

Ref.	€ HT
150.00XL	61,11
150.01XL	61,11
150.02XL	61,11
150.03XL	61,11
150.04XL	61,11
150.05XL	61,11

Design

Ref.	€ HT
150.00D	53,47
150.01D	53,47
150.02D	53,47
150.03D	53,47
150.04D	53,47
150.05D	53,47

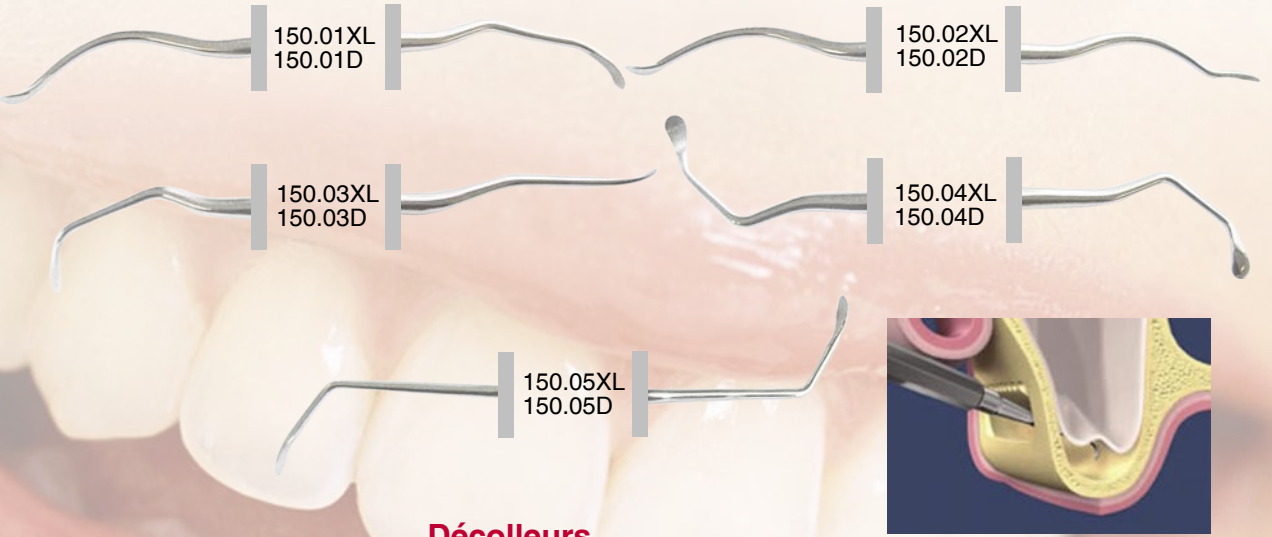

Décolleurs
Periosteal elevators - Raspatorien - Periostomos

BENQUE



GOLDMAN-FOX

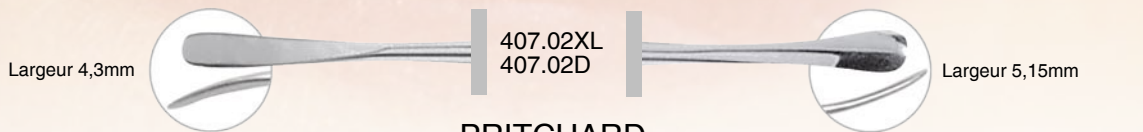

PRITCHARD

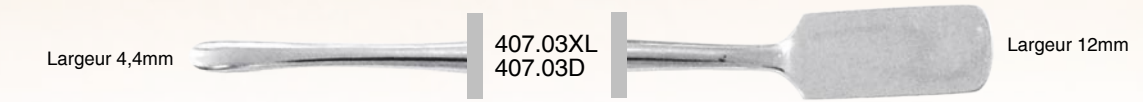

HOURIGAN

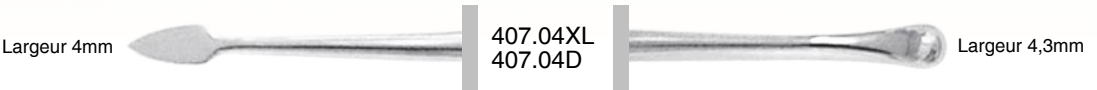

MOLT D7

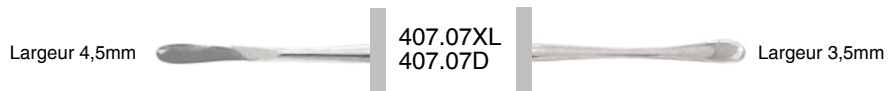

MOLT D8

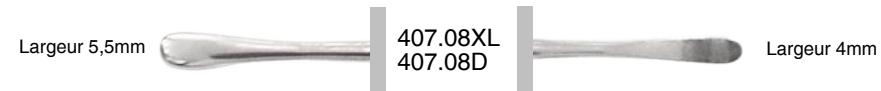

MOLT D9

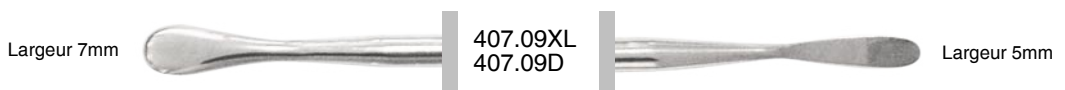

XL Style

Ref.	€ HT
407.01XL	42,54
407.02XL	53,47
407.03XL	42,54
407.04XL	42,54
407.07XL	42,54
407.08XL	42,54
407.09XL	53,47

Design

Ref.	€ HT
407.01D	35,96
407.02D	39,25
407.03D	34,90
407.04D	34,90
407.07D	35,96
407.08D	35,96
407.09D	44,77

Miroirs millimétrés

Millimetric mirrors - Graduerte Spiegel - Espejos graduados

Aide précieuse en implantologie et prothèse grâce aux lignes espacées de 8mm: elles facilitent le parallélisme des préparations prothétiques et des axes implantaires.

Ref.	€ HT
MP3000P	11,35
MP5000P	32,25
MZP214	58,99



MP3000P



MP5000P

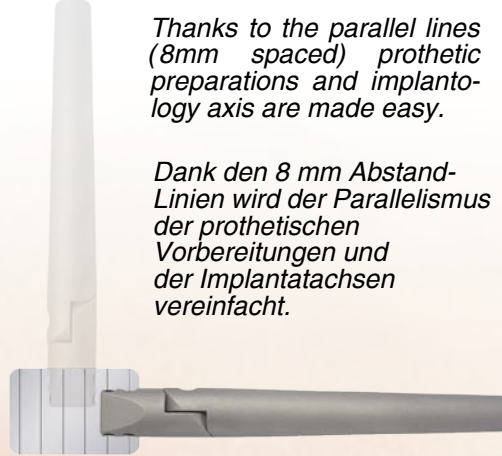

Thanks to the parallel lines (8mm spaced) prothetic preparations and implantology axis are made easy.

Dank den 8 mm Abstand-Linien wird der Parallelismus der prothetischen Vorbereitungen und der Implantatachsen vereinfacht.

Aynda imprescindible en implantología y prótesis gracias a las líneas qe cada 8 mm facilitan el paralelismo de las preparaciones protéticas y de sus ejes.

Manche pour miroirs photographiques MZP214
Holder for photographic mirrors
Halter für Fotospiegel
Mango para espejos fotograficos

CANULES D'ASPIRATION + MIROIRS

Suction cannulas - Absaugkanüle - Cánulas de aspiracion

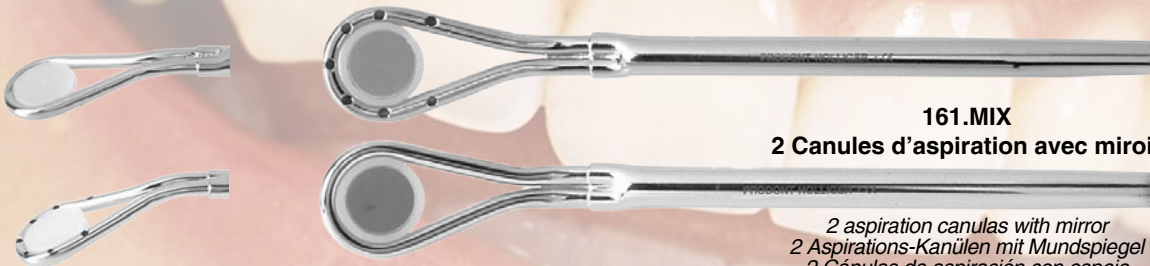

161.MIX
2 Canules d'aspiration avec miroir

2 aspiration canulas with mirror
2 Aspirations-Kanülen mit Mundspiegel
2 Cánulas de aspiración con espejo



160.PMI
5 pastilles miroir pour canule

5 plastic discs with mirror for canula
5 Plastscheiben für Aspirationskanüle
5 pastillas de plastico con espejo

Ref.	€HT
161.MIX	74,25
160.PMI	26,65

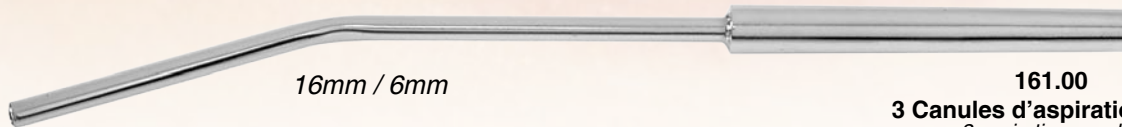

16mm / 6mm

161.00
3 Canules d'aspiration fines
3 aspiration canulas
3 Aspirations-Kanülen
3 Cánulas de aspiración



160.00AD
Adaptateur canule/pompe à salive
Adaptor for canula and saliva ejector
Adapter für Aspirations-Kanülen
Adaptador para cánula y bomba de saliva

Ref.	€HT
161.00	79,04
160.00AD	9,76

Cassette de stérilisation

(16x10,5x5 cm)

10 plugs + 1 bassin

Sterilisation tray - Sterilisierungs-Kassette - Casete



Ref.	€HT
300.02	125,15

DÉCOLLEUR DE PAPILLE

NOUVEAUTÉ
NEW



407.12XL

manche XL Style handle



IMPLANTOLOGIE

CUILLÈRE À OS DU Dr FALCON

NOUVEAUTÉ
NEW



395.01XL



XL Style

Ref.	€ HT
407.12XL	42,54
395.01XL	49,50
150.06XL	51,91

MINI DÉCOLLEUR DE SINUS

NOUVEAUTÉ
NEW



150.06XL



Tournevis droit ou angulé *Straight or angulated screwdriver*

- Pour visser ou dévisser manuellement les pièces prothétiques.
- Compatible avec tous les embouts qui se montent sur les contre angle.
- Longueur importante et petit diamètre permettant de se placer à la perpendiculaire des pièces sans problème.
- Système de cardan pour rotation à distance.
- Très apprécié sur les zones buccales postérieures.
- Avec bague de verrouillage, peut être utilisé comme un tournevis droit.

- Used to manually screw or unscrew prosthetic parts..
- Compatible with all contra angle tips.
- Long size and small diameter to allow optimal positioning above parts.
- Universal joint for distant rotation.
- Very helpful on posterior oral zones.
- With locking ring, can be used as a straight screwdriver.



300.07



Ref.	€ HT
300.07	220,83
300.10	286,44



300.10

Très pratique pour intervenir dans les zones difficilement accessibles et à faible encombrement, le tournevis contre-angle est compatible avec les outils de toutes les marques.

*Very handy, the contra-angle screwdriver can access small and difficult areas. It's compatible with all tips brands.
Sehr praktisch für Eingriffe in schwer zugänglichen und platzmangelnden Bereichen, der Schraubendreher ist kompatibel mit Werkzeugen aller Marken.
Muy práctico para intervenir en las zonas difíciles, el destornillador contra-ángulo es compatible con los instrumentos de todas las marcas*



Tourne à gauche / Left/Links / Izquierdo / Tourne à droite / Right/ Rechts / Derecho

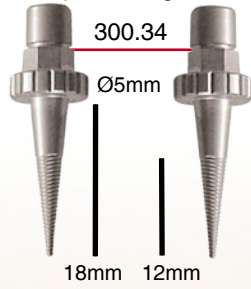

KIT pour dent longue / grande ouverture de bouche
For Long tooth / wide mouth aperture
Lang / Largo

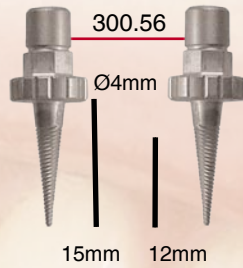
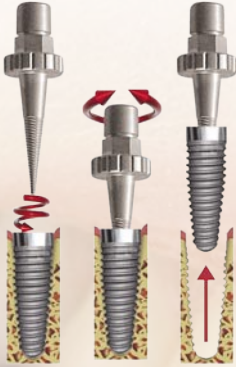

KIT pour dent courte / petite ouverture de bouche
For Short tooth / small mouth aperture
Kurz / Corto

EXTRACTEURS D'IMPLANTS

Moins traumatisants en implantologie, les extracteurs minimisent les pertes osseuses en évitant l'utilisation de fraise trépan. Les douleurs post-opératoires sont réduites et il est possible de réimplanter lors de la même séance.

En cas d'ostéointégration avancée, déstabiliser l'implant de la table osseuse avec des ultrasons. Utiliser alternativement les extracteurs gauche et droit pour rompre progressivement la liaison osseuse.

Pour un implant mal ostéointégré, visser l'extracteur gauche dans l'implant pour le faire remonter.

IMPLANT EXTRACTORS

Less traumatizing in implant surgery, they minimize the osseous losses by avoiding bone drilling and surgery during the extraction of an implant. Both left and right extractors are screwed and unscrewed alternatively into the implant to gradually separate it from the bone.

Ref.	€ HT
300.34	256,47
300.56	256,47

300.12



EXTRACTEUR DE VIS

L'extracteur de vis permet de remonter en tournant à gauche une vis dont la tête est abîmée (percer préalablement un trou avec la fraise Ø0,6mm). Il se fixe sur contre-angle ou adaptateur universel pour clé dynamométrique. (Diamètre 2mm, longueur 22mm, pointe Ø0,44mm)

SCREW EXTRACTOR

The screw extractor allows to raise a damaged screw by turning to the left (use a drill Ø0,6mm beforehand to make a hole in the screw). Adjustable on contra angle or universal adapter for torque ratchet key. (Diameter 2mm, length 22mm, point Ø0,44mm)

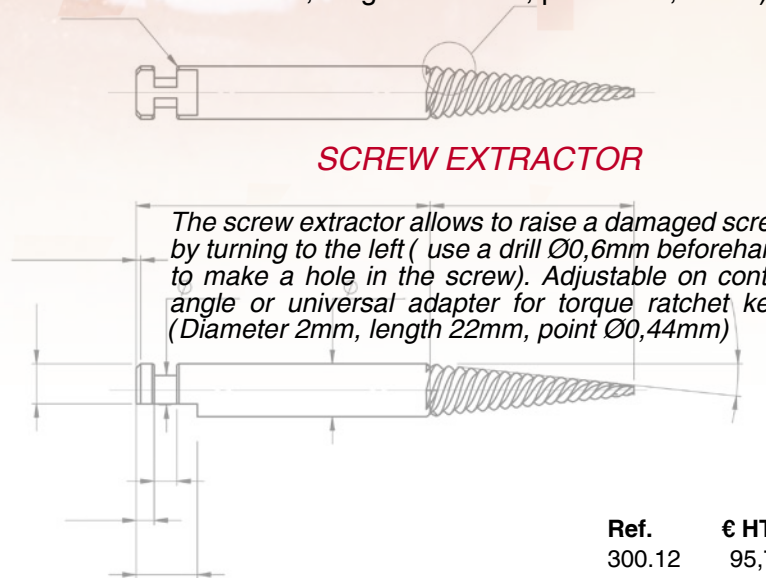

Ref.	€ HT
300.12	95,79



Echelle 2:1
Scale



L'extracteur de vis se fixe sur contre angle ou sur l'adaptateur universel (ref. 300.09)

The screw remover fits on the adapter or contra-angle instrument.

Der Schrauben-Extraktor kann mit Hand- und Winkelstücken oder dem Universal Adapter benutzt werden.
El extractor de tornillos se adapta con los contrángulos o con el adaptador universal

ADAPTATEUR UNIVERSEL pour vos tournevis contre angle

Universal adapter for contra angle instruments
Universal-Adapter für Ihren Winkelstück-Schraubendreher
Adaptador UNIVERSAL para sus destornilladores contra-ángulos



300.09

CLE à CLIQUET / DYNAMOMETRIQUE

Torque Ratchet Key / Drehmoment Ratsche
Llave a carraca dinamométrica



300.01

10/40 N/cm

KIT CLÉ + ADAPTATEUR

Adapter+Key/Adapter+Ratsche/Adaptador+Llave



300.19



KIT 2 EXTRACTEURS D'IMPLANTS + CLÉ

Extractors+Key/Entfernungsinstrument+Ratsche/Extractores



Kit
300.20

Longs
Long / Lang / Largo

Kit
300.21

Courts
Short / Kurz / Corto

KIT EXTRACTION DE VIS avec 1 extracteur de vis, 1 fraise boule.

Screw Extraction set incl. 1 screw extractor, 1 drill



300.27

KIT EXTRACTION DE VIS avec clé, adaptateur, 1 extracteur de vis, 1 fraise

Screw Extraction set incl. ratchet key, adapter, 1 screw extractor, 1 drill



300.26

KIT D'EXTRACTION

avec clé, adaptateur, 2 extracteurs d'implants, 1 extracteur de vis, 1 fraise boule, 1 cassette de stérilisation.

300.24: avec extracteurs longs

300.25: avec extracteurs courts



Ref.	€ HT
300.01	282,12
300.09	52,32
300.19	298,60
300.20	513,97
300.21	513,97
300.24	675,17
300.25	675,17
300.26	386,77
300.27	111,14

Extraction set incl. ratchet key, adapter, 2 implant extractors, 1 screw extractor, 1 drill, 1 sterilisation tray.
300.24: with long extractors
300.25: with short extractors

Ces modèles pédagogiques par excellence reproduisent fidèlement la dentition d'un enfant de 4 ou 9 ans, sur une base de résine transparente permettant la visualisation des dents de sagesse en préparation.



9 ans / 9 years old / 9 Jahre / 9 años

These teaching models faithfully imitate the full dentition of a 4 or 9 years old child clearly visible through the simulated gum work and shows the wisdoms in formation.

Die in pädagogischer Hinsicht überaus empfehlenswerten Modelle A4 und A9 spiegeln exakt die Bezahnung eines 4 - 9 jährigen Kindes wider. Dank des transparenten Kunststoffmaterials sind die im Zahnfleisch noch verborgenen Weisheitszähne sichtbar.

Los modelos A4 y A9 , pedagógicos por excelencia, reproducen fielmente la dentición de un niño de 4 o 9 años sobre una base de resina transparente que permite la visualización de las muelas del juicio en formación.

Avec Charnière métal / metal hinge

Ref. €HT
41/0904 461,49



4 ans / 4 years old / 4 Jahre / 4 años

Avec Charnière plastique / Plastic hinge

Ref. €HT
41/09042 397,84

Avec Charnière métal / metal hinge

Ref. €HT
41/0907 472,10

Avec Charnière plastique / Plastic hinge

Ref. €HT
41/09072 423,30



Le modèle Typodont montre le résultat d'un traitement orthodontique.

The Typodont model shows the result of an orthodontic treatment.

Das Modell Typodont zeigt das Ergebnis nach der kieferorthopädischen Behandlung.

El modelo Typodont es el resultado de la ortodoncia.



Ref. €HT
42/1715R 110,33

Malaxe tous vos alginates en 5 secondes sans bulles!

For all alginates! - Mischt alle Ihre Alginate! Mezcla todos los alginatos!



économique, simple, rapide et hypoallergénique
ecological, simple, fast et hypoallergenic

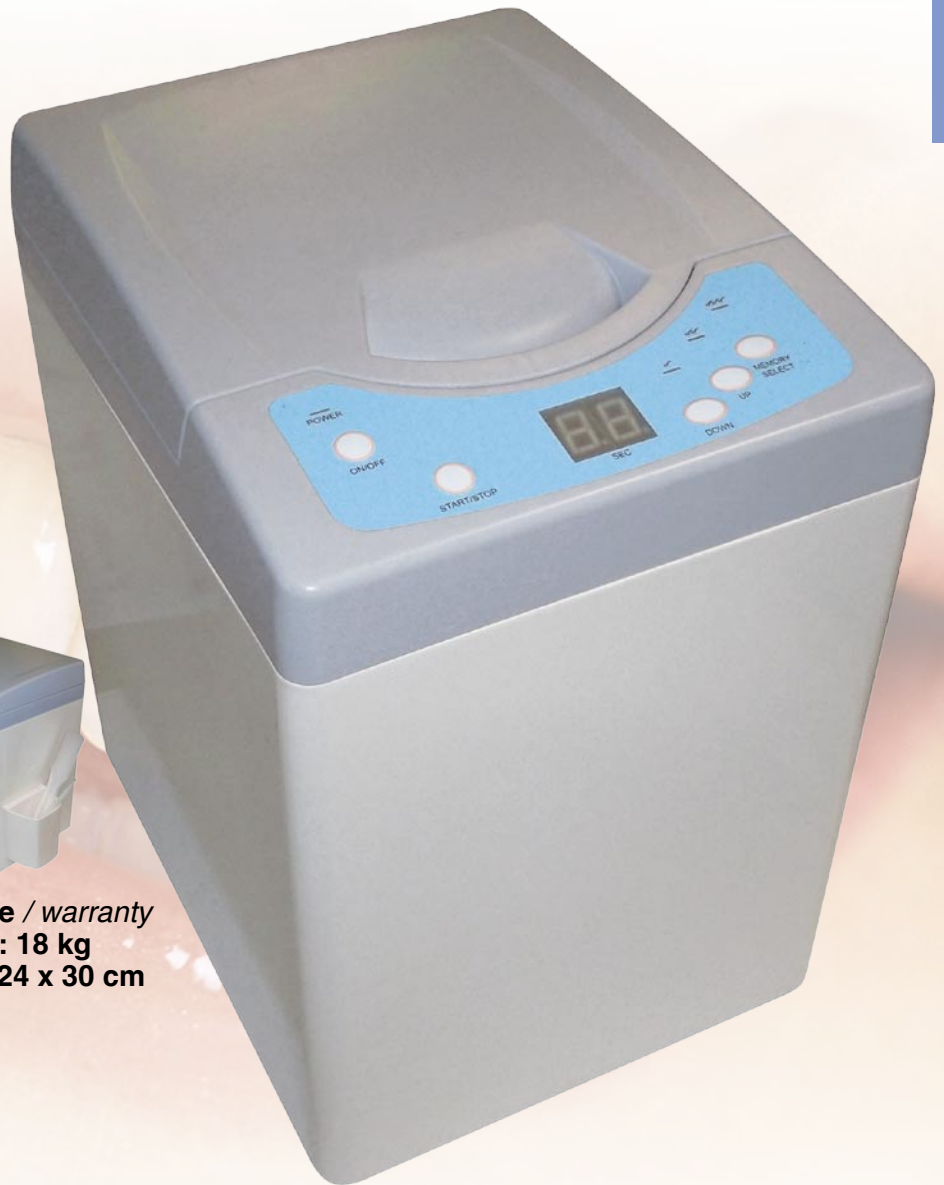

18 mois de garantie / warranty

Poids / weight : 18 kg

Dimensions: 20 x 24 x 30 cm

Ref.	€ HT
3055.00	1092,00
3055.01	18,54
3055.02	12,36
3055.03	41,20

Esthétique, discret
encombrement réduit, faible poids
Utilisation simple

Nice, discreet
Light weight, small size
Ease of use

-Type planétaire, double rotation du bol (3600 tours par minute)
-Temps de malaxage ultra rapide (pâte sans bulle, homogène)

For an impression simple, fast, economic and hypoallergenic - extremely simple Handling - Planetary Type, double rotation of the bowl (3600 turns per minute) - fast cycle (paste without bubble, homogeneous)

Mischgerät für Alginat
Für einfache, schnelle, kostengünstige und hypallergene Abdrücke
extrem einfache Handhabung, Planeten-Typ Doppel Rotation (3600 rpm), ultraschnelle Mischzeit (blasenfreie und homogene Mischung)

Para una huella simple rápida económica e hipoalergénica
Manipulación extremadamente simple, Doble rotación de la taza a 3600 vueltas/minuto, Tiempo de mezcla muy rápido (pasta sin gránulos, muy homogénea)



3055.03
flacon
doseur



3055.02
spatule +
mélangeur



3055.01
le bol

Vendu avec tous les accessoires.

Accessories included

Zubehör inbegriffen

Vendido con todos los accesorios

ORTHODONTIE

Mélangeur à alginates
Alginates mixer

Pincers - Zangen - Alicates

ORTHODONTIE

Pincers - Zangen - Alicates



877.00

10cm

Pince à plier les fils et les crampons
Wire and clasp bending pliers
Draht und Klammerbiegezange
Alicates para doblar alambres y ganchos

Pince pour tous les crochets, même boule, avec deux séries d'encoches, aux extrémités et à la base des mors pour retenir et stabiliser les fils. Le diamètre de fil maximum est de 0,7mm. Très maniable grâce à sa taille réduite (10 cm), elle allie toutes les qualités des pinces Aderer, pour la finesse, et Waldsachs, pour la robustesse.

These pliers are suitable for all wire up to 0,7mm and all clasps. Two sets of notches, at the base and the end of the jaws, stabilize the wire. Very handy thanks to its reduced size (10 cm), it combines the quality of Aderer and Waldsachs pliers.

Zange zum Anpassen aller gängigen Klammern und Haken. Mit zwei verschiedenen Rillentiefen zur besseren Fixierung des Drahtes. Maximaler Drahtdurchmesser 0.7 mm. Nur 10 cm lang und dadurch sehr handlich verbindet sie alle Qualitäten der Aderer oder Waldsachs Zangen.

alicates para todos los ganchos, incluso redondos, con dos series de muescas, en las extremos y en las bases de la tenaza para retener y estabilizar los hilos. El diámetro de hilo máximo aceptado es de 0,7mm. Muy prácticos gracias a su tamaño reducido (10 cm), y a su combinación de las cualidades de las pinzas Aderer (finura), y Waldsachs (robustez).



886.00

15cm

ADERER
Pince à plier les barres
Lingual bar bending pliers
Bügelbiegezange
Alicates para doblar barras

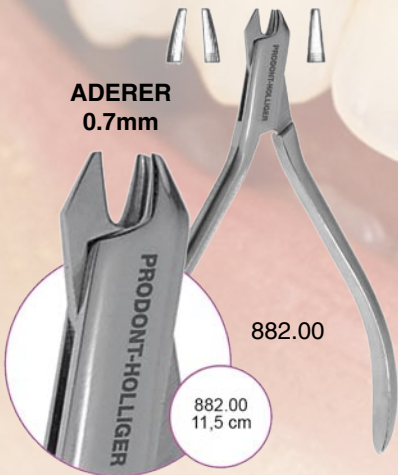

ADERER
0.7mm

882.00

882.00
11,5 cm

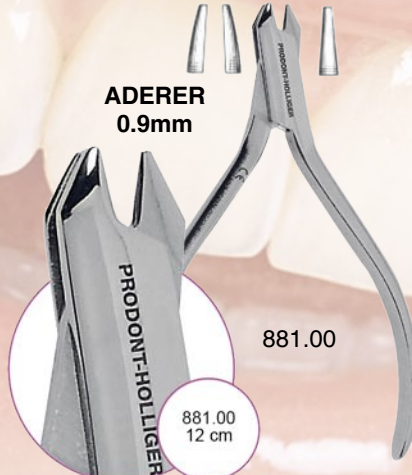

ADERER
0.9mm

881.00

881.00
12 cm



801.00

11cm

Pince à cintrer les arcs rectangulaires
Arcs bending pliers
Bogenbiegezange
Alicates para arcos

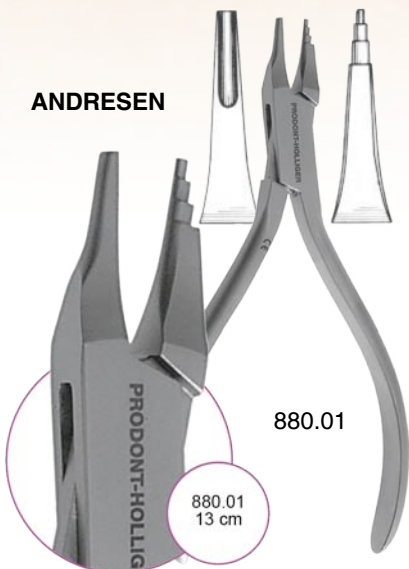

ANDRESEN

880.01

880.01
13 cm

TWEED
Pince à courber les anses
Loop bending pliers
Schlaufenbiegezange - Alicates para formar ondulaciones



880.00

14cm

Ref.	€ HT
801.00	66,62
877.00	67,69
878.00	85,19
880.00	73,20
880.01	66,62
881.00	52,94
882.00	52,94
886.00	63,34

HOLLOW CHOP



Pince à débiquer



WEINGART



WALDSACHS

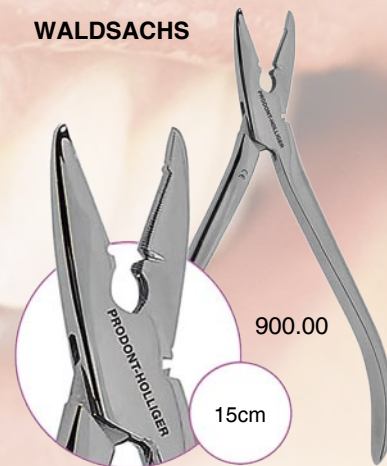

HOW

Pinces à serrer bagues et ligatures
Band pinching & ligature locking plier
Band und Ligaturanlegezangen
Alicates para ajustar bandas y ligaduras

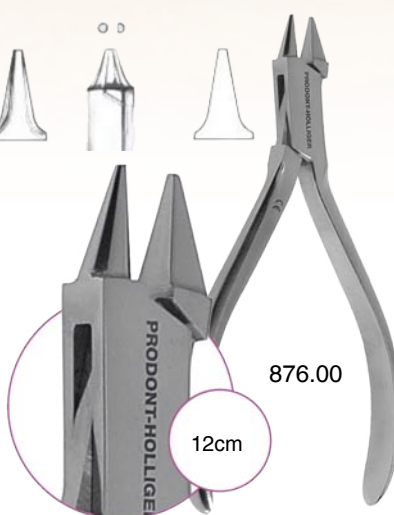

Ref.	€ HT
802.00	92,83
803.00	66,62
804.00	86,25
832.00	66,94
867.00	52,94
868.00	52,94
875.00	52,94
876.00	63,87
900.00	73,20

ADAMS

ANGLE

Tranchants obliques / Side snippers
Seitenschneider / Filo oblicuo

Pinces à clamps
Pliers - Zangen - Alicates

ORTHODONTIE
Pinces à clamps
Pliers - Zangen - Alicates



PALMER 17,5cm
866.00

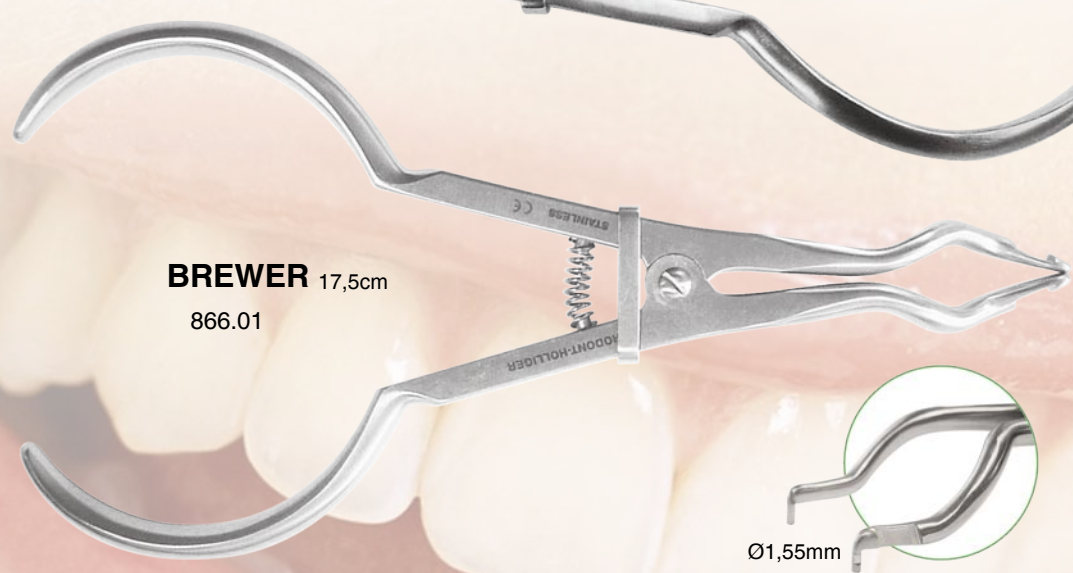

BREWER 17,5cm
866.01

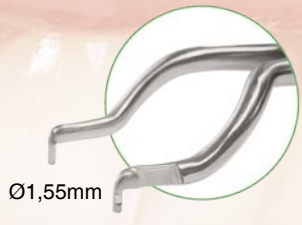

Ciseaux à couronnes
Crown scissors - Kronenscheren - Tijeras para coronas

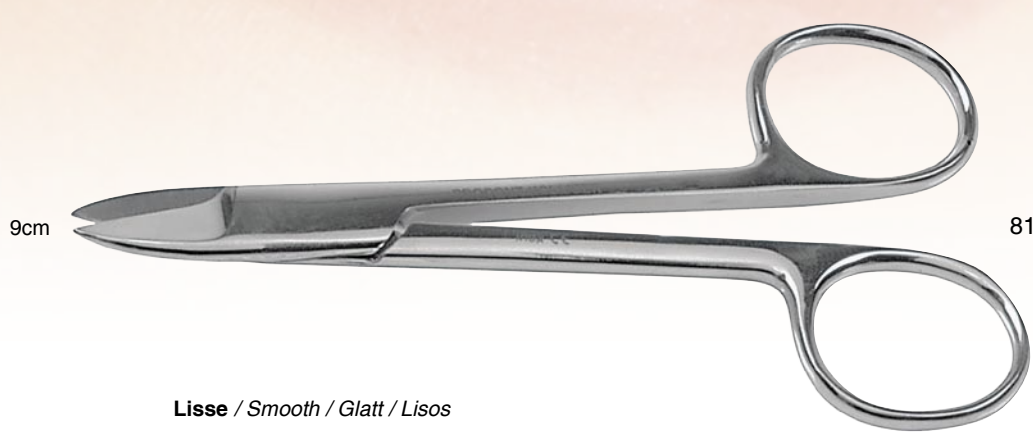

9cm

810.00

Lisse / Smooth / Glatt / Lisos



9cm

811.00

Ref.	€ HT
810.00	11,88
811.00	14,00
866.00	71,29
866.01	71,29

MATHIEU
Porte-aiguille
Needle holder - Nadelhalter - Porta agujas

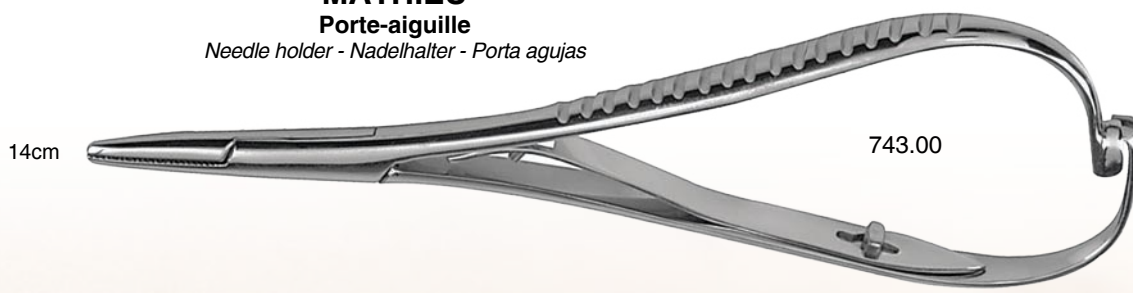

14cm

743.00

Enfonce-bague

Band puscher - Bandsetzer - Asentador de bandas



155.00

Ref.	€ HT
155.00	75,25
743.00	42,54

SHURE

Enfonce-bague / Grattoir à ciment

Band pusher & cement scraper - Bandsetzer - Asentador de bandas



155.01D

manche Design handle

Spatules à fil

Thread slot spatula - Spatel mit Fadenfurche - Espatulas para hilo



154.00XL

manche XL Style handle

Design

Ref.	€ HT
154.00D	27,27
154.00GD	27,27
154.01D	27,27
155.01D	55,70



154.00GXL
154.00GD

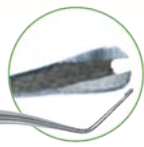

grande encoche
Large slot
Große Fadenfurche
Grande

XL Style

Ref.	€ HT
154.00GXL	39,25
154.00XL	39,25
154.01XL	39,25



154.01XL
154.01D



Non-crantée
Without thread slot

BOLS A PLATRE & ALGINATES

Bowls - Becher - Cubetas



1599.00
Ø12cm, H. 9,5cm



1598.00
Ø10cm, H. 7,5cm



1597.00
Ø8cm, H. 6cm

Bols Ultra Souples

Extra flexible bowls



1596.00
500ml
Ø13cm, H. 9cm



1596.01
250ml
Ø10cm, H. 6cm



1596.02
100ml
Ø8cm, H. 5cm

Spatule

Spatula - Spateln - Espátulas



4520.00

Couteau Mammouth

Knife - Messer - Cuchillas



1996.00

Spatules

Spatulas - Spateln - Espátulas



4518.00



4527.00

Pince

Forceps - Schneidezangen - Tenazas



2254.01

Ref.	€ HT
1596.00	8,59
1596.01	6,47
1596.02	4,67
1597.00	7,43
1598.00	10,75
1599.00	12,52
1996.00	11,03
2254.01	40,63
4518.00	10,61
4520.00	2,65
4527.00	11,90

Cire à modeler Prima été,
plaques de 19,5x8,5cm
Modelling wax Prima summer, sheets



1Kg CP1620.10
500g CP1620.05

Cire à modeler Prima hiver,
plaques de 19,5x8,5cm
Modelling wax Prima winter, sheets



1Kg CP1621.10
500g CP1621.05

CP1680
Cire à mordu, 50 pcs.
Bite wax



Conditionnement 500g ou 1Kg

Cire à modeler Spéciale rouge
plaques de 19,5x8,5cm
Modelling wax Special Red, sheets



1Kg CP1641.10
500g CP1641.05

Cire à modeler Standard 2, plaques de 19,5x8,5cm
Modelling wax Standard 2, sheets



1Kg CP1651.10
500g CP1651.05

CP1680D
Cire à mordu dure, 50 pcs.
Bite wax, hard



Ref.	€ HT
CP1620.05	22,49
CP1620.10	44,13
CP1621.05	22,49
CP1621.10	44,13
CP1641.05	22,49
CP1641.10	44,13
CP1651.05	22,49
CP1651.10	44,13
CP1661.10	44,13
CP1680	20,90
CP1680D	20,90

MILLER

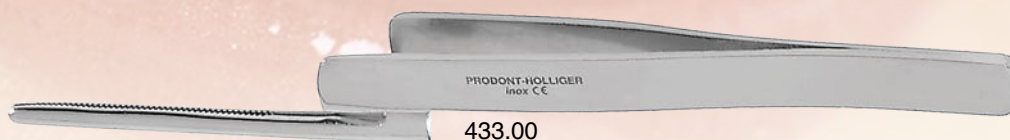

433.00

FAHNSTOCK



Couteaux à cire
Knives - Messer - Cuchillas

2067.16



2065.17

Modèle TYPODONT

Ref.	€ HT
2065.17	8,91
2067.16	8,91
433.00	20,69
FT42/1715R	110,33

FT42/1715R



Ecarteurs

Cheek retractors - Wangenhalter - Separadores



151.20 (adulte)
Adult / Erwachsene / Adulto



151.21 (enfant)
Child / Kinder / Niño

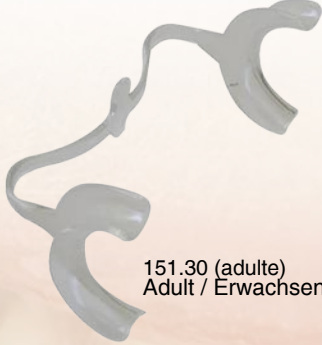

151.30 (adulte)
Adult / Erwachsene / Adulto



151.31 (enfant)
Child / Kinder / Niño

Avec retenue linguale
With lingual stop
Mit Zungenhalter
Con moderación lingual



151.40 (adulte)
Adult / Erwachsene / Adulto



151.41 (enfant)
Child / Kinder / Niño

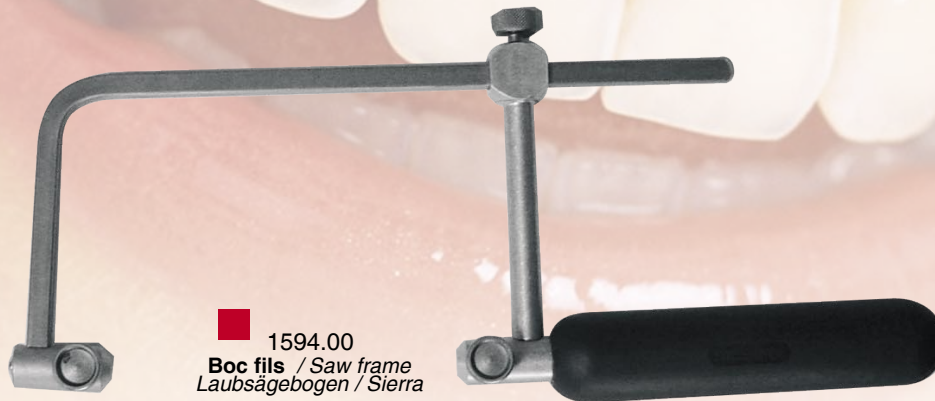

1594.00
Boc fils / Saw frame
Laubsägebogen / Sierra



1594.02
12 Lames / blades
Sägeklingen / Cuchillas

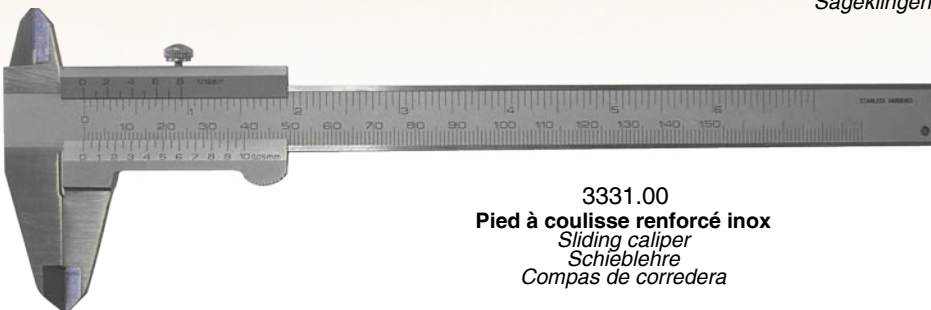

3331.00
Pied à coulisse renforcé inox
Sliding caliper
Schieblehre
Compas de corredera



3331.01
Pied à coulisse numérique renforcé inox
Sliding caliper
Schieblehre
Compas de corredera

Ref.	€ HT
151.20	4,99
151.21	4,99
151.30	6,58
151.31	6,58
151.40	4,99
151.41	4,99
1594.00	35,90
1594.02	6,05
3331.00	39,70
3331.01	70,97

Jusqu'à épuisement des stocks
Until the end of stocks / So langer der Vorrat reicht / Hasta el final del existencia

Godets extra souples silicone

Flexible silicone bowls / Becher aus Silikon / Pocillos extra flexibles

Munis de ventouse pour une plus grande stabilité.
With suction pad / Mit Saugnapf / Con ventosas



Ref.	€ HT
151.20	4,99
151.21	4,99
151.30	6,58
151.31	6,58
151.40	4,99
151.41	4,99
1595.00	7,32
1595.01	5,30
1595.02	4,14
1595.03	2,86
1595.04	2,55
1596.00	8,59
1596.01	6,47
1596.02	4,67
4520.00	2,65

1595.00 95ml

1595.01 30ml

1595.02 15ml

1595.03 10ml

1595.04 5ml



1596.00
500ml
Ø13cm, H. 9cm



1596.01
250ml
Ø10cm, H. 6cm



1596.02
100ml
Ø8cm, H. 5cm



Spatule
4520.00

Godets Dappen Recyclables

disposable dishes - Becher - Pocillos

x100



Ref.	€ HT
1592.00	1,59
1592.01	1,59
1592.02	1,59
1592.03	1,59
1593.00	10,50
1593.01	10,50
1593.02	10,50
1593.03	10,50
1593.04	10,50

Godets Dappen en verre 10 / 2ml

Glass Dappen dishes / Dappenglas / Pocillos en vaso



Jusqu'à épuisement des stocks
Until the end of stocks / So langer der Vorrat reicht / Hasta el final del existencia

Séquenceurs de fraises

Bur holder - Bohr-Ständer - Secuenciador de fresas

Supports endodontiques

Endodontic holder - Halter für Nervnadeln - Soporte endodontico

Ref.	€HT
bleu 3121.02	11,03

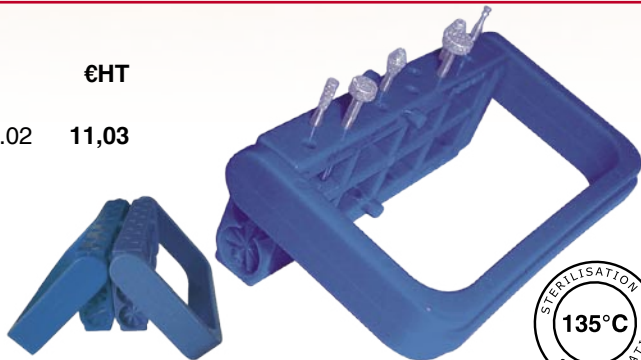

Anse de protection réglable 3 hauteurs
Protective handle with 3 adjustable heights
Einstellbarer Schutz-Bügel, mit 3 verschiedenen Höhenverstellungen
Asa de proteccion con 3 alturas de fresas posible

12 emplacements pour tiges de 2mm+12 de 2,5mm
12 holes for 2mm bur stem+12 for 2,5mm bur stem
Für 12 Bohrer 2mm+12 für Bohrer 2,5mm
12 emplazamientos para fresas 2mm+12 para fresas 2,5mm

Ref.	€HT
vert 3121.10	11,03
bleu 3121.11	11,03

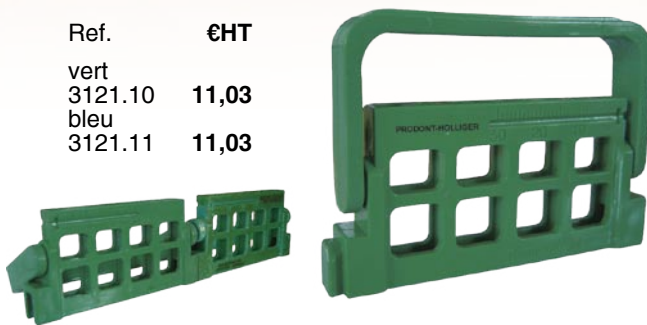

Règle millimétrée
millimetric ruler / Millimeter-Angabe / regla milimetrada

8 emplacements
8 slots / für 8 Nervnadeln / 8 emplazamientos

Assemblage de plusieurs supports
modular / mehrere Ständer können zusammengefügt werden
/ ensablaje de varias soportes





HC
Spray nettoyant prêt à l'emploi
élimine efficacement les taches et les traces de doigts sur l'acier inoxydable.
Hollinox Clean rend un brillant éclatant sans laisser de traces résiduelles.
Il n'a pas besoin d'être rincé ou séché.
contenance: 500ml



HR
Nettoyant pour aciers inoxydables.
Il élimine en profondeur la rouille et les traces d'oxydation sur l'inox.
Ne contient pas de particules abrasives.
S'utilise également sur l'aluminium, le cuivre et l'acier ordinaire.
Convient à un nettoyage intensif de surfaces contaminées par la rouille ou par d'autres formes de corrosion, communément appelées "taches de thé".
Inoffensif à l'égard des métaux, mais très agressif envers les oxydes et les impuretés.
contenance: 500ml



HOLLINOX CLEAN & REMOVE

Nettoient et préviennent toute trace et tache d'oxydation sur toute surface et instrument.

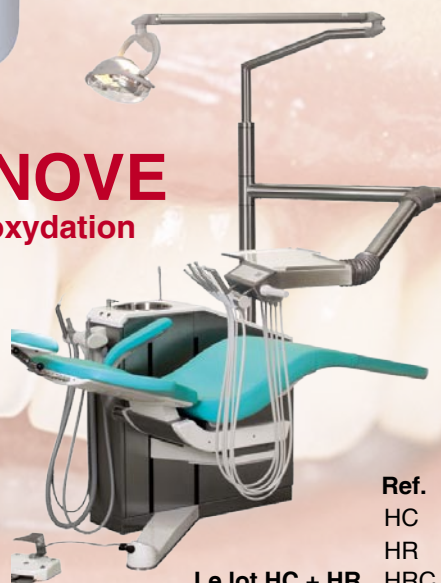

Ref.	€ HT
HC	40,17
HR	67,98
Le lot HC + HR	HRC 119,71



3520.00

Lunettes de protection
Protection glasses / Protektionsbrille
Gafas de proteccion



2190.00

Gratte-Brosse
Bur cleaning brush / Bohrer-Bürste
Brochas Card

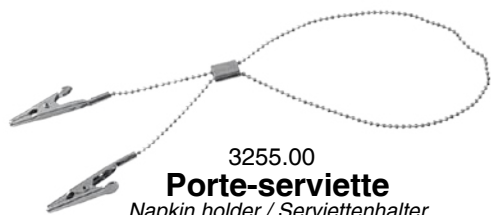

3255.00

Porte-serviette
Napkin holder / Serviettenhalter
servilletero



3018.00

Pot à coton inox
Cotton wool holder / Wattebehälter
Algodonera

Ref.	€ HT
2190.00	4,77
3018.00	70,97
3255.00	11,88
3520.00	13,47



233.25
Cassette inox 18x28x3 cm
1000 grammes
Stainless steel tray (20 instr.)
Sterilisierungs-Kassette - Casete

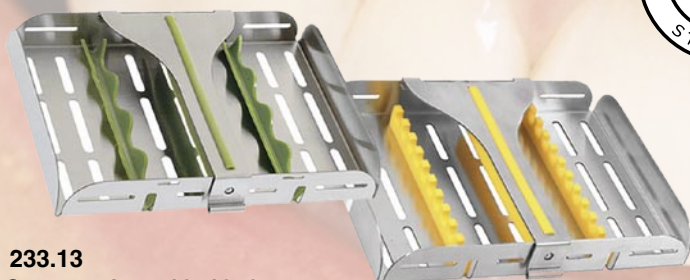

233.13
Cassette inox 18x13x2,5 cm
avec silicone 4 emplacements
Stainless steel tray (4 instr.)
Sterilisierungs-Kassette - Casete

233.14
Cassette inox 18x13x2,5 cm
avec silicone 10 emplacements
Stainless steel tray (10 instr.)
Sterilisierungs-Kassette - Casete

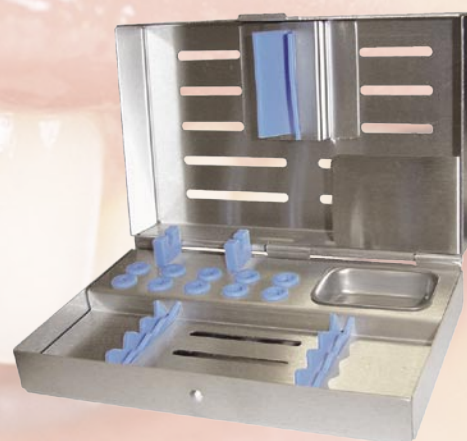

300.02 Cassette de stérilisation
(16x10,5x5 cm)
10 plugs + 1 bassin
Sterilisation tray - Sterilisierungs-Kassette - Casete

Easyclip

8 instruments
180x136x30mm
Matière: PSU
90g



233.30

Ref.	€ HT
233.13	50,39
233.14	51,67
233.25	121,24
233.30	27,27
300.02	125,15

Réassort Silicone
Silikoneinlage / Silicona

vert, 4 instr.	233.16	11,88
jaune, 10 instr.	233.17	12,41

Plateaux inox
Stainless steel tray
Instrumenten Schale
Bandeja de acero inoxidable



233.10
20x10 cm



233.15
20x15 cm

Laboratoire



Liberty Sculpt

LA gamme pour **Flamme** et **No-Flamme** que vous attendiez.

THE ultimate instruments range for Flame et Induction.

Die Neue Instrumentenlinie für Brenner mit Flamme oder Induktion.

La nueva gama de instrumentos para quemadores a gas e induccion.

Au choix: Créez votre instrument...

Assemble your own instrument. / Kreieren Sie Ihr persönliches Instrument. / Cree su propio instrumento.



Choisissez les figures à visser sur l'entretoise...

Choose the tips / Anzuschraubenden Figuren / Atornille su instrumento



175.01ALS
PKT n°1 figure 1 diam 1,2



175.01BLS
PKT n°1 figure 2 diam 0,9



175.02ALS
PKT n°2 figure 1 diam 0,7



175.02BLS
PKT n°2 figure 2 diam 0,5



196.00ALS
Lecron figure 1 lame



196.00BLS
Lecron figure 2 ronde



197.00ALS
Zalhe figure 1 lame



197.00BLS
Zalhe figure 2 pointe



4515.07ALS
Spatule à cire n°7 figure 1 pointe



4515.07BLS
Spatule à cire n°7 figure 2 spatule



4517.00ALS
Spatule à cire cuillère figure 1 pointe



4517.00BLS
Spatule à cire cuillère figure 2 spatule



610.00ALS
Bistouri, figure porte-lame



101.00ELS
Embout aveugle

...sans oublier les indispensables:

Indispensable / Unentbehrlich



100.00ELS

Entretoise

Spacer / nur Griff / Mango central



100.00BLS

Présentoir

*Stand
Präsentierständer
Expositor*

Ref.	€ HT
100.00BLS	159,45
100.00ELS	6,37
101.00ELS	20,16
175.01ALS	20,16
175.01BLS	20,16
175.02ALS	20,16
175.02BLS	20,16
196.00ALS	29,49
196.00BLS	29,49
197.00ALS	30,55
197.00BLS	28,11
4515.07ALS	30,55
4515.07BLS	28,11
4517.00ALS	30,55
4517.00BLS	28,11
610.00ALS	39,50

...ou choisissez l'instrument **standard.**
choose an instrument / Wählen Sie ein Instrumente / Escoja un instrumento

Appuie-doigts **souples:**
confort et résistance
 à haute température (200°C)

Manche INOX ergonomique **gros diamètre:**
 Evite le syndrome du **canal carpien.**

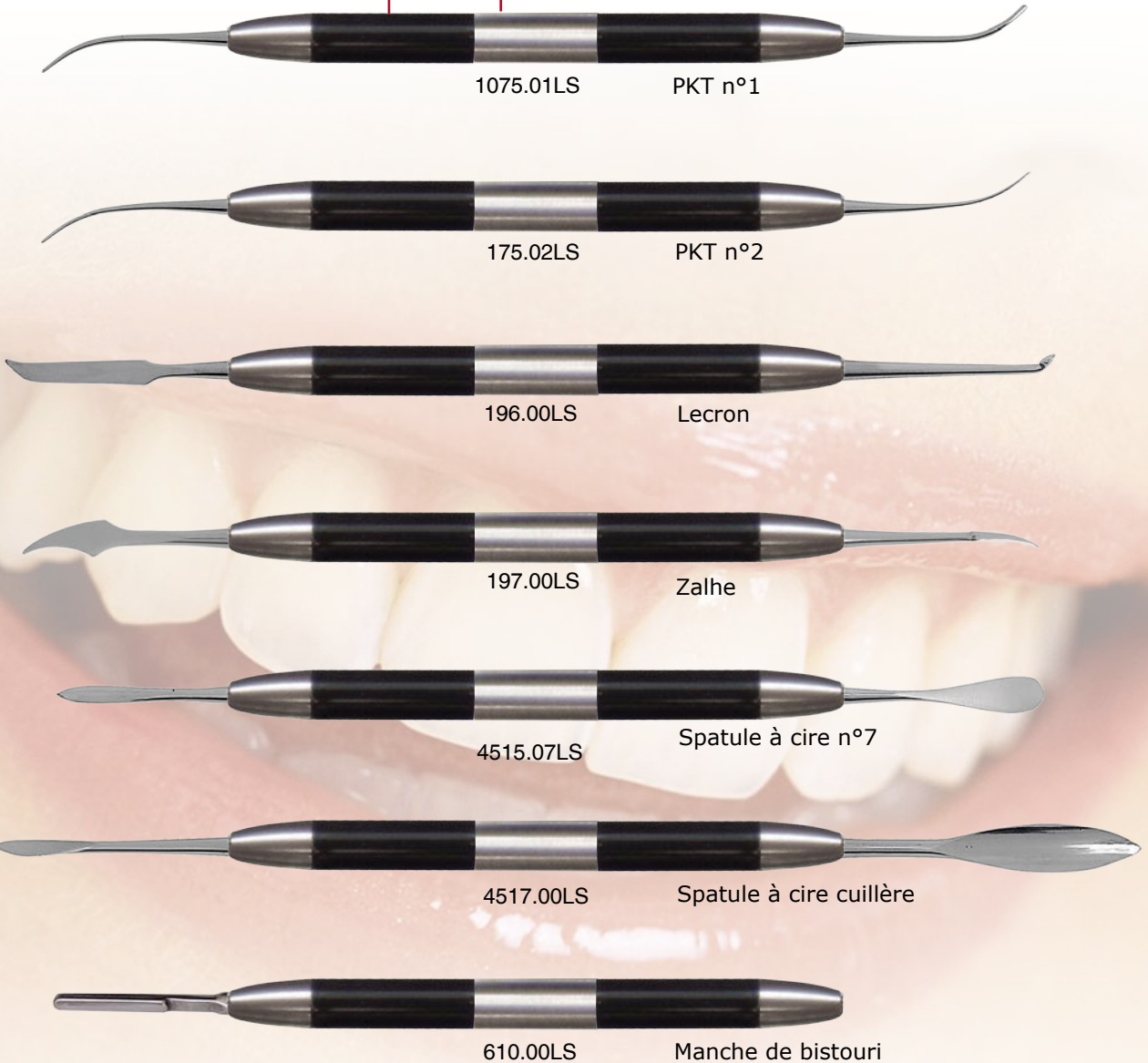

Stainless steel instruments with smooth handle and large diameter to reduce the carpal tunnel syndrome.

Aus Edelstahl mit Silikon-Isolierungseinsätzen für ein gutes Handling. großer Durchmesser Verhindert das Karpaltunnel-Syndrom.

Inox con fundas aislantes de silicone, de grand diametro, evita el síndrome del tunel carpiano.

Ref.	€ HT
101.00LS	472,77
175.01LS.	42,54
175.02LS.	42,54
196.00LS.	57,71
197.00LS.	57,82
4515.07LS.	57,82
4517.00LS.	57,82
610.00LS.	57,82

101.00LS
 Kit 6 instruments + Présentoir
Set 6 instr. + Stand
Set mit 6 Instrumenten+Präsentierständer
Estuche 6 instr. + expositor



Liberty Sculpt

POINTE PARFAITE ET TREMPE EXCELLENTE

PERFECT POINT AND DIPPING.



- Poil de martre naturel / *Natural marten hair / Haar von Marder / pelo de marta*
- Résistance, élasticité et souplesse. / *Resistance, elasticity, flexibility / Widerstand, Elastizität, Geschmeidigkeit*
- Taille du manche / *Handle / Halter / mango : 16cm*
- 8 tailles / *sizes / Größe / talla*



Kit 8 pinceaux
Set of 8 pencils / 8 Pinsel / 8 pinseles

Ref.	€HT
191.01LS	63,65

Ref.	€HT
190.00LS	5,52
190.01LS	5,73
190.02LS	6,26
190.03LS	6,90
190.04LS	7,32
190.05LS	7,96
190.06LS	12,20
190.08LS	17,50





Ref. €HT
2530.00 105,03

- Design ergonomique: grande visibilité
- Pièces en aluminium ultra léger: confort d'utilisation
- Eléments inférieurs et supérieurs séparables: préparation des cires facilitée
- Montage interchangeable de haute précision sans outil
- Aimants de positionnement: disposition des modèles simple et rapide
- Mouvements latéral et protrusif sans à coup
- Inclinaison condyalaire de 25°

Contient: 2 plaques de montage, 1 tige incisive, 4 disques métalliques

*Ergonomic design for enhanced visibility.
Light-weight Aluminium frame.
Separable parts.
Magnetic mounting system.
Smooth lateral and protrusive movements.
25 degrees condylar inclination.*

*Ergonomisches Design: sehr übersichtlich
Ultra leichte Aluminium-Teile: Benutzerfreundlichkeit
Abnehmbare obere und untere Elemente: Erleichterung der
Wachsvorbereitung
Hochpräzise Montage ohne Werkzeug. Für mehrere Modelle
anwendbar.
Magnet-Positionierung: einfaches und schnelles Anbringen der Modelle
Reibungslose seitliche und Protrusionsbewegungen
Condylar Neigung von 25 °
Enthält: 2 Montageplatten, Ein Stützstift, 4 Metall*

*Design ergonómico para una mejor visibilidad
Piezas en aluminio ultra ligero para un mejor confort de utilización
Elementos inferiores y superiores separables : facilita la preparación de
ceras
Montaje intercambiable de alta precisión sin herramienta
Imanes de posicionamiento : disposición de modelos simple y rápida
Movimiento lateral y protrusivo
Inclinación condilar de 25°
Contiene : 2 placas de montaje, 1 tallo incisivo, 4 metalica*



4 aimants
4 magnets



Pinces
Pliers - Zangen - Alicates

INSTRUMENTS

Pinces
Pliers - Zangen - Alicates



JOHNSON



PEESO
Lisse / Smooth / Glatt / Lisos

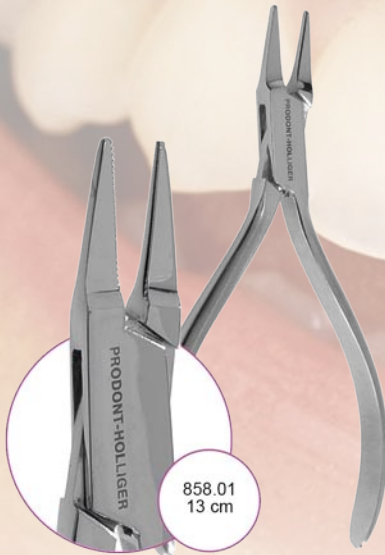

PEESO
Striée / Serrated / Gerieft / Estriados



REYNOLDS
Pince à bouteroller: permet de recréer le retrait cervical de la coiffe pédodontique.



PEESO
Pince à élargir les bagues
Crown stretching
Kronenstreckzange
Alicates para ensanchar coronas



HOW
Pince à serrer bagues et ligatures
Band pinching & ligature locking plier
Band und Ligaturanlegezangen
Alicates para ajustar bandas y ligaduras



HOW
Pince à serrer bagues et ligatures
Band pinching & ligature locking plier
Band und Ligaturanlegezangen
Alicates para ajustar bandas y ligaduras

€HT
La pince **52,94**

Pinces Pliers - Zangen - Alicates

Pinces universelles
Universal bending pliers
Universal Kramponzangen
Alicates universales

€HT
la pince **73,20**

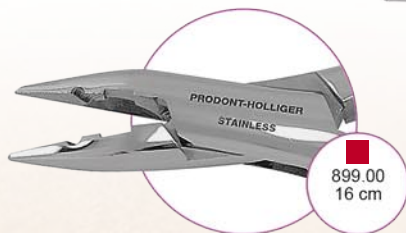

899.00
16 cm

Jusqu'à épaulement des stocks
Until the end of stocks / So langer der Vorrat
reicht / Hasta el final del existencia

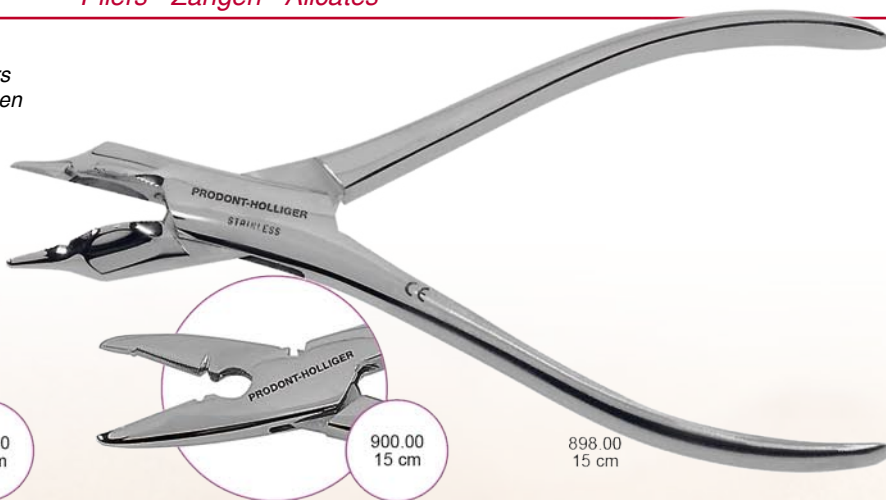

900.00
15 cm

898.00
15 cm

WALDSACHS

Pinces plates
Flat pliers
Flachzangen
Alicates chatos

€HT
la pince **52,94**

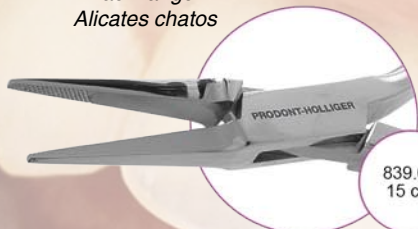

839.00
15 cm

Striée / Serrated / Gerieft / Estriados

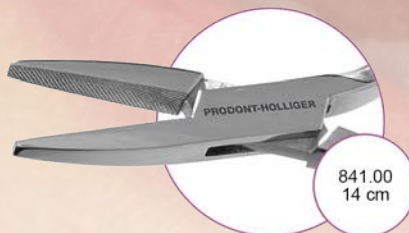

841.00
14 cm

Striée / Serrated / Gerieft / Estriados



852.00
diam 1,6 mm
852.01
diam 0,8 mm
14 cm

Striée / Serrated / Gerieft / Estriados



838.00
15 cm

Lisse
Smooth
Glatt
Lisos

Pinces 1/2 rondes / 1/2 Round pliers
1/2 Rundzangen / Alicates 1/2 redondos

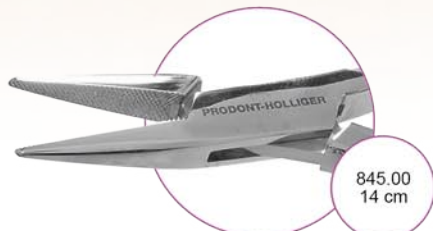

845.00
14 cm

Striée / Serrated / Gerieft / Estriados



844.01
12 cm

Lisse / Smooth / Glatt / Lisos



846.00
14 cm

€HT
la pince **52,94**

GOSLEE

1 Lisse 1 strié / 1 Smooth 1 serrated /
1 Glatt 1 gerieft / 1 lado liso, 1 estriado



844.00
14 cm

Lisse
Smooth
Glatt
Lisos

Pinces
INSTRUMENTS

Pliers - Zangen - Alicates

Pinces
Pliers - Zangen - Alicates

Pince pour tous les crochets, même boucle, avec deux séries d'encoches, aux extrémités et à la base des mors pour retenir et stabiliser les fils. Le diamètre de fil maximum est de 0,7mm. Très maniable grâce à sa taille réduite (10 cm), elle allie toutes les qualités des pinces Aderer, pour la finesse, et Waldsachs, pour la robustesse.

These pliers are suitable for all wire up to 0,7mm and all clasps. Two sets of notches, at the base and the end of the jaws, stabilize the wire. Very handy thanks to its reduced size (10 cm), it combines the quality of Aderer and Waldsachs pliers.

Zange zum Anpassen aller gängigen Klammern und Haken. Mit zwei verschiedenen Rillentiefen zur besseren Fixierung des Drahtes. Maximaler Drahtdurchmesser 0.7 mm. Nur 10 cm lang und dadurch sehr handlich verbindet sie alle Qualitäten der Aderer oder Waldsachs Zangen.

alicates para todos los ganchos, incluso redondos, con dos series de muescas, en las extremos y en las bases de la tenaza para retener y estabilizar los hilos. El diámetro de hilo máximo aceptado es de 0,7mm. Muy prácticos gracias a su tamaño reducido (10 cm), y a su combinación de las cualidades de las pinzas Aderer (finura), y Waldsachs (robustez).

INSTRUMENTS

Pinces
Pliers - Zangen - Alicates

Pince à plier les fils et les crampons
Wire and clasp bending pliers
Draht und Klammerbiegezange
Alicates para doblar alambres y ganchos



877.00

10cm

ADERER
Pince à plier les barres
Lingual bar bending pliers
Bügelbiegezange
Alicates para doblar barras

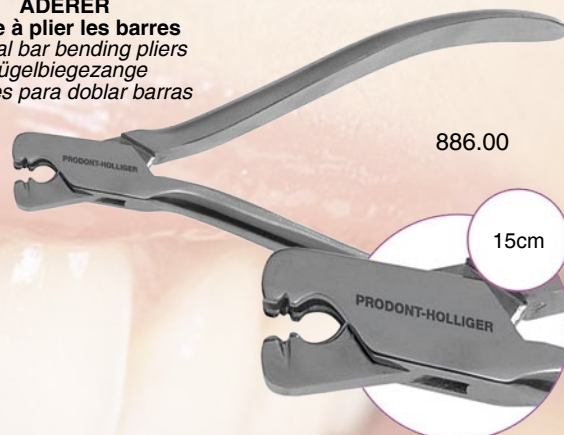

886.00

15cm

ADERER
0.7mm

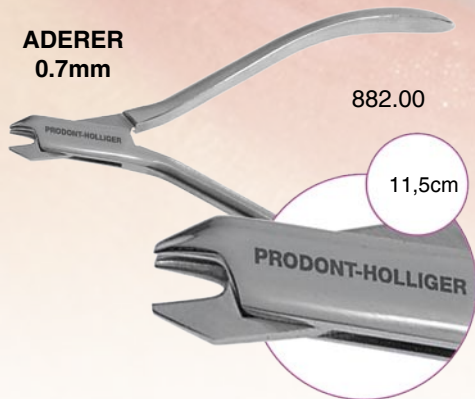

882.00

11,5cm

ADERER
0.9mm

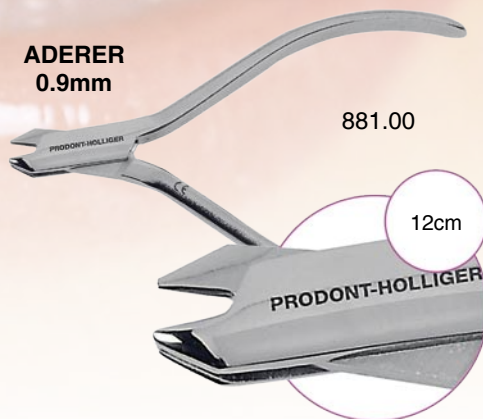

881.00

12cm

Pince à cintrer les arcs rectangulaires
Arcs bending pliers
Bogenbiegezange
Alicates para arcos

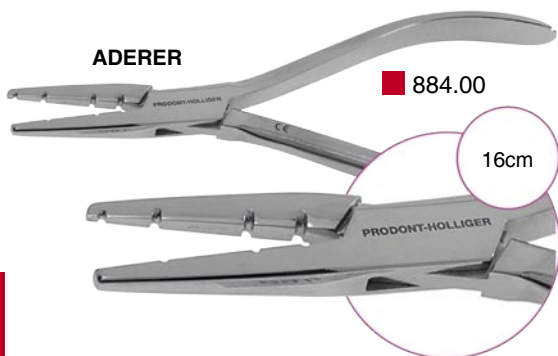

ADERER

884.00

16cm

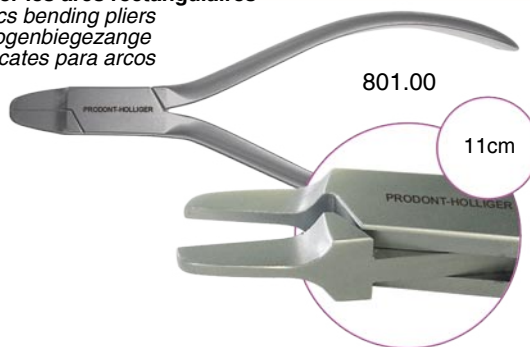

801.00

11cm

Ref.	€ HT
801.00	66,62
877.00	67,69
881.00	52,94
882.00	52,94
884.00	56,23
886.00	63,34

Jusqu'à épuisement des stocks
Until the end of stocks / So langer der Vorrat reicht / Hasta el final del existencia

Pince Mosquito Porte-Céramique

Plier with ceramic holder ring
Mosquito Zange mit Ring, «Keramikhalter»
Pinza porta cerámica



724.01



724.01S

Pince Mosquito fine
Les mors fins, courbes et crantés apportent maniabilité et précision.

This fine, curved and threaded plier allows better precision.

feines Maulteil, gebogen und gezahnt.

Las puntas finas curvas y rayadas proporcionan más manejabilidad y precisión

CRILLE

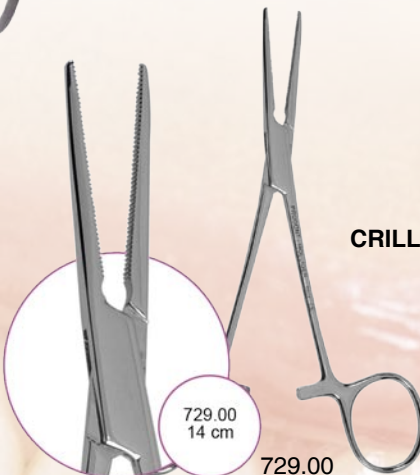

729.00
14 cm

729.00



730.00
14 cm

730.00

FURRER



897.00

897.00
14 cm



890.00

890.00
14 cm

SAUZEAT

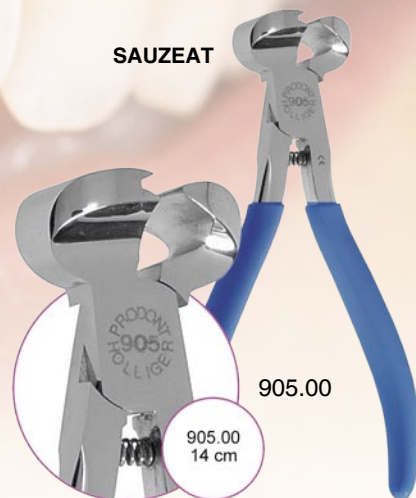

905.00

905.00
14 cm

SCHWARZ

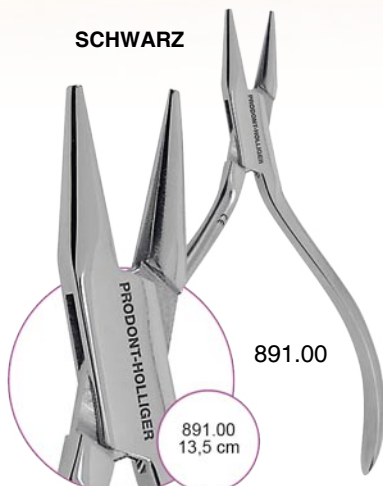

891.00

891.00
13,5 cm

SCHWARZ



892.00

892.00
13 cm

SCHWARZ



894.00

894.00
14 cm

Ref.	€ HT
724.01S	23,34
729.00	19,10
730.00	19,10
890.00	63,76
891.00	63,76
892.00	63,76
894.00	76,49
897.00	70,97
905.00	238,17

Pinces
Pliers - Zangen - Alicates

INSTRUMENTS

Pinces
Pliers - Zangen - Alicates

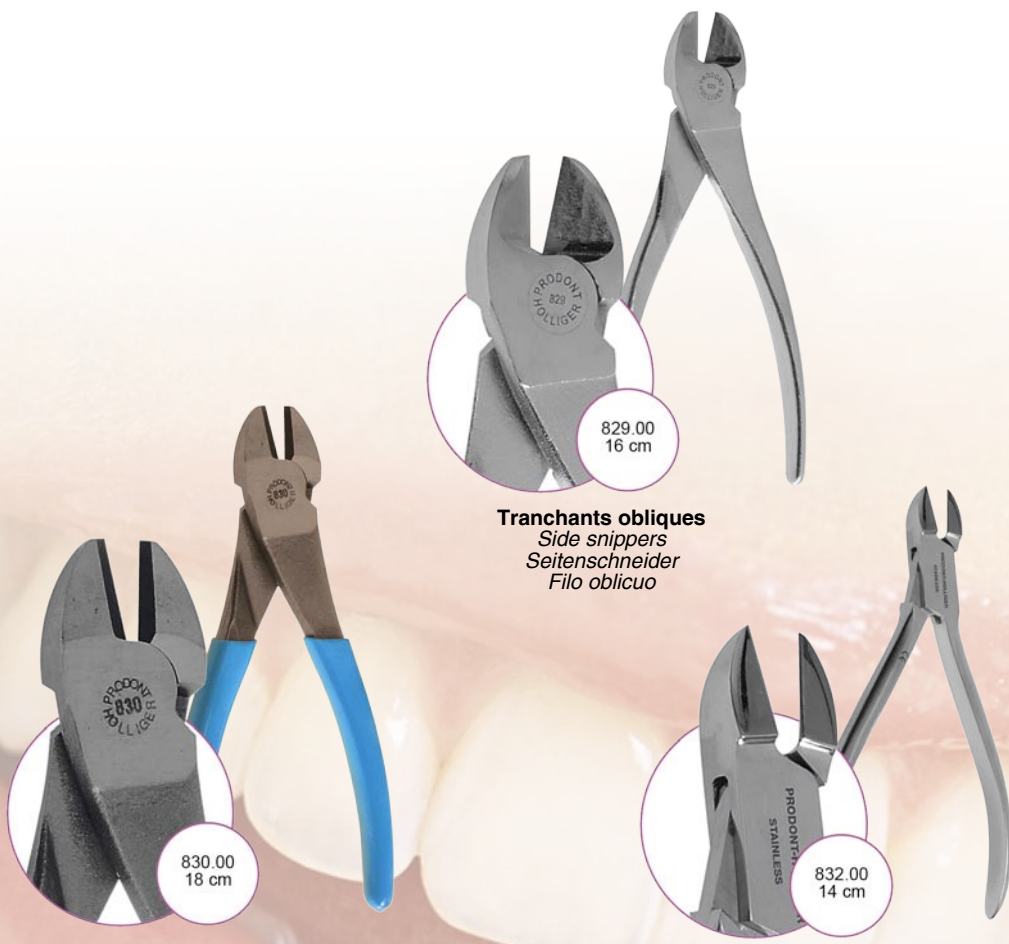

Ref.	€ HT
829.00	55,70
830.00	58,60
832.00	66,94

Tranchants obliques
Side snippers
Seitenschneider
Filo oblicuo

Tranchants obliques / Side snippers
Seitenschneider / Filo oblicuo

Ciseaux à couronnes
Crown scissors - Kronenscheren - Tijeras para coronas

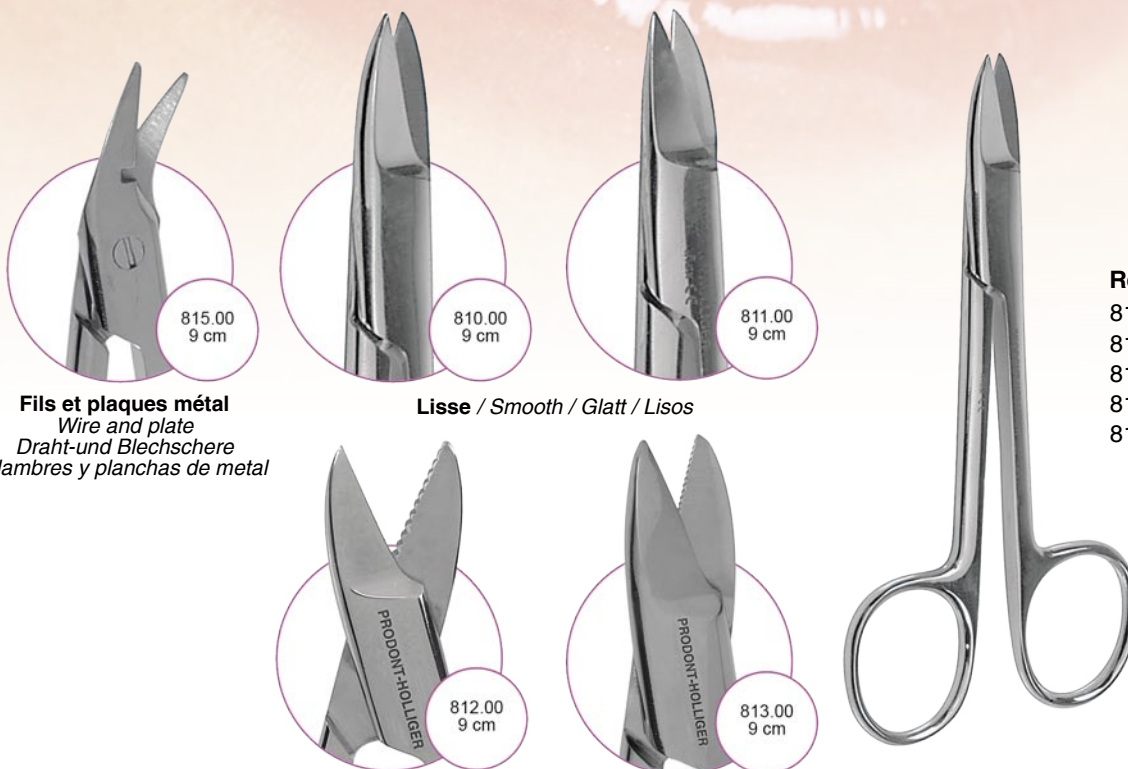

Ref.	€ HT
810.00	11,88
811.00	14,00
812.00	14,22
813.00	15,17
815.00	16,34

Fils et plaques métal
Wire and plate
Draht-und Blechscherer
Alambres y planchas de metal

Lisse / Smooth / Glatt / Lisos

Crantés / Saw edge / Gezahnt / Dentadas

Droits / Straight
Gerade / Derecha

Courbes / Bent
Gebogen / Curvas



Pince à courber les anses
Loop bending pliers
Schlaufenbiegezange
Alicates para formar ondulaciones



Ref.	€ HT
803.00	66,62
804.00	86,25
875.00	52,94
876.00	63,87
880.00	73,20
880.01	66,62

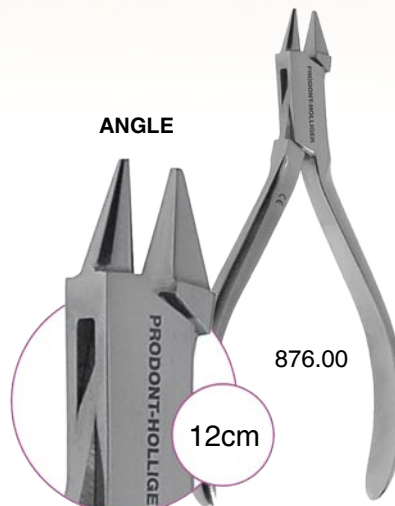
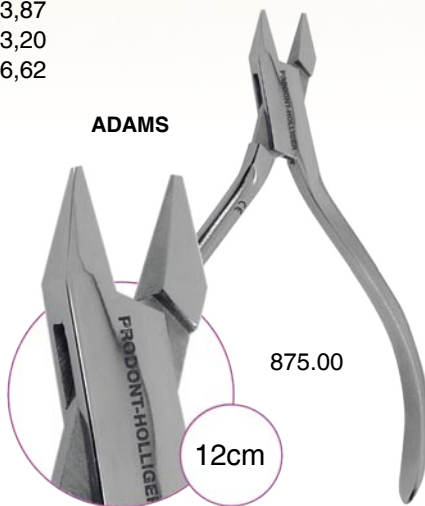

OLIVIER
Pince à plier les ressorts et arcs
Arch & spring bending pliers
Feder- u. Bogenbiegezange
Alicates para doblar resortes y arcos

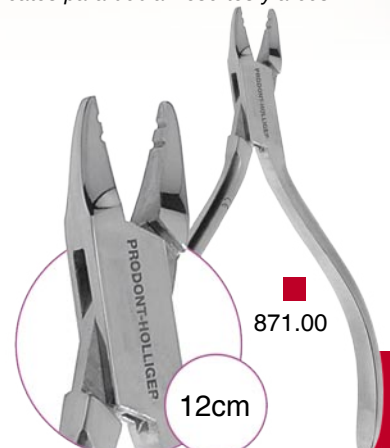

Instrumentes pour la cire

Instruments for wax work - Wachs-Instrumente - Talladores y espátulas para cera



Flamme

Spatule

248.00



Flamme

lancette

248.01

Ref.	€ HT
248.00	9,97
248.01	14,32

Spatules ultra flexibles

Extra-flexible spatulas - Zementspateln - Espatulas extra-flexibles



Flamme

marque **XLStyle** *handle*

246.18XL



Flamme

marque **Design** *handle*

246.19D



Flamme

246.18TXL
246.18TD



Flamme

246.20XL
246.20D



Flamme

246.20TXL
246.20TD

FRAHM 6/10



120.00XL

XLStyle

Ref.	€ HT
120.00XL	38,19
194.01XL	27,80
194.02XL	27,80
246.18TXL	40,42
246.18XL	27,27
246.19XL	27,27
246.20TXL	40,42
246.20XL	27,27

WARD



194.01D

Design

Ref.	€ HT
120.00D	30,55
194.01D	17,50
194.02D	17,50
246.18D	22,75
246.18TD	27,27
246.19D	22,75
246.20D	22,75
246.20TD	27,27

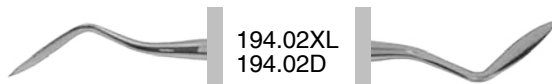

194.02XL
194.02D

Nouveautés Spéciales Zircono



Précelle avec mors plastifiés
Tweezer with soft jaws.



3477.00P



Pince avec mors plastifiés
Forceps with soft jaws.



868.00P

Disques zircono.
Abrasive disc for zirconia



Ref. 2203Z (vendu à l'unité): Diam. 22mm, épaisseur / *thickness* 0,3mm: 22€15 HT
 Ref. 2205Z (vendu à l'unité): Diam. 22mm, épaisseur / *thickness* 0,5mm: 22€15 HT
 Ref. 2215Z (vendu à l'unité): Diam. 22mm, épaisseur / *thickness* 1,5mm: 24€51 HT

POUR FLAMME ET INDUCTION

for flame and induction / für Flamme und Induktion / Para Llave y induccion

INSTRUMENTS

Instruments pour la cire
Instruments for wax work - Wachs-Instrumente - Talladores y espátulas para cera



4514.02



4517.00



4515.07



4516.34

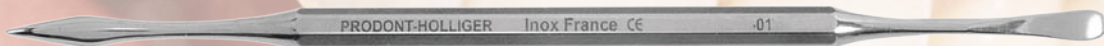

1923.01



1923.02



1923.03

ROACH



195.00

LE CRON



196.00

LE CRON Mini

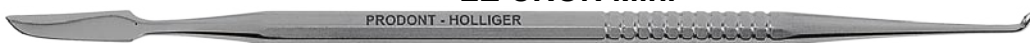

196.01

Ref.	€ HT
1923.01	17,40
1923.02	18,57
1923.03	19,63
195.00	50,18
196.00	20,90
196.01	33,84
4514.02	25,04
4515.07	27,27
4516.34	29,49
4517.00	25,04

POUR FLAMME ET INDUCTION

for flame and induction / für Flamme und Induktion / Para Llave y induccion

ZALHE



197.00

ZALHE



197.01

REEVES



198.00

PETER THOMAS

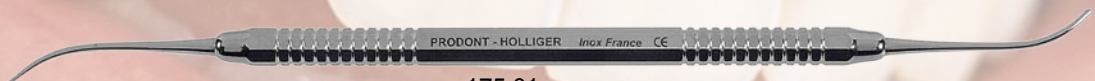

175.01



175.02

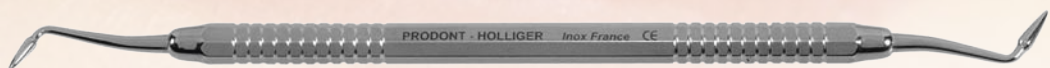

175.03



175.04



175.05

175.00

Jeu de 5 instruments
PETER THOMAS
5 instruments Set
5 Wachs-Instrumente-Set
Juego de 5 instrumentos

Ref.	€ HT
175.00	75,00
175.01	17,29
175.02	17,29
175.03	17,29
175.04	14,00
175.05	14,00
196.02	24,51
197.00	19,10
197.01	23,70
198.00	27,27

DENTAL PRECIS



196.02

Instruments pour la cire
Instruments for wax work - Wachs-Instrumente - Talladores y espátulas para cera

INSTRUMENTS

Instruments pour la cire
Instruments for wax work - Wachs-Instrumente - Talladores y espátulas para cera

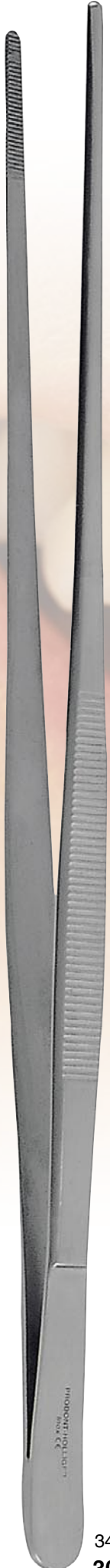

3478.00
30cm



12cm 2023.00



GENEVE 11,5cm 2253.00



3477.00



4510.00



4511.00

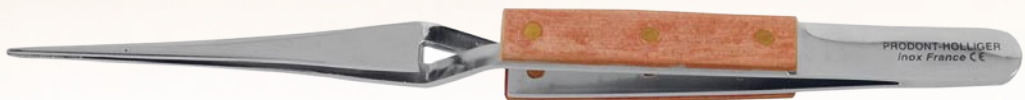

4512.00



4513.00

Ref.	€ HT
2023.00	10,72
2253.00	9,90
3477.00	14,70
3478.00	32,57
4510.00	16,02
4511.00	16,02
4512.00	18,35
4513.00	18,35



127.15



130.18



2067.16



2065.17



4526.14

Ref.	€ HT
127.15	42,54
130.18	21,32
2065.17	8,91
2067.16	8,91
4526.14	21,22

Bols à plâtre

*Bowls
Becher
Cubetas*



1599.00
Ø12cm, H. 9,5cm



1598.00
Ø10cm, H. 7,5cm



1597.00
Ø8cm, H. 6cm

Bols ultra flexibles

*Flexible Bowls
Flexibel Becher
Flexibles Cubetas*



ref. 1596.00
500ml
Ø13cm, H. 9cm



ref.1596.01
250ml
Ø10cm, H. 6cm



ref.1596.02
100ml
Ø8cm, H. 5cm

Ref.	€ HT
1596.00	8,59
1596.01	6,47
1596.02	4,67
1597.00	7,43
1598.00	10,75
1599.00	12,52

Pinces pour le plâtre

Forceps for plaster - Schneidezangen für Gips - Tenazas para Yeso



EXTRA FORTE avec gaine 2254.00



EXTRA FORTE 2254.01



STANDARD 2254.02

Ref.	€ HT
2254.00	65,25
2254.01	40,63
2254.02	33,84



4520.00

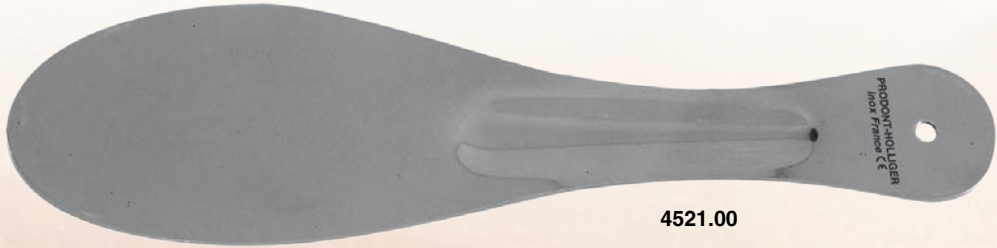

4521.00



4527.00



4518.00



Super Master

4207.00



GRITMAN

1997.00



MAMMOUTH

1996.00



1995.00



Master, ROSEWOOD

1754.00

Ref.	€ HT
1754.00	10,72
1995.00	11,75
1996.00	11,03
1997.00	10,72
4207.00	13,90
4518.00	10,61
4520.00	2,65
4521.00	11,14
4527.00	11,90

Moufles HOLY
Denture flasks - Holy Küvetten - Muflas

INSTRUMENTS

Moufles HOLY
Denture flasks - Holy Küvetten - Muflas

40cm

40cm



1777.00

Pince à cylindre standard

Crucible tongs / Zylinder Zange / Tenazas

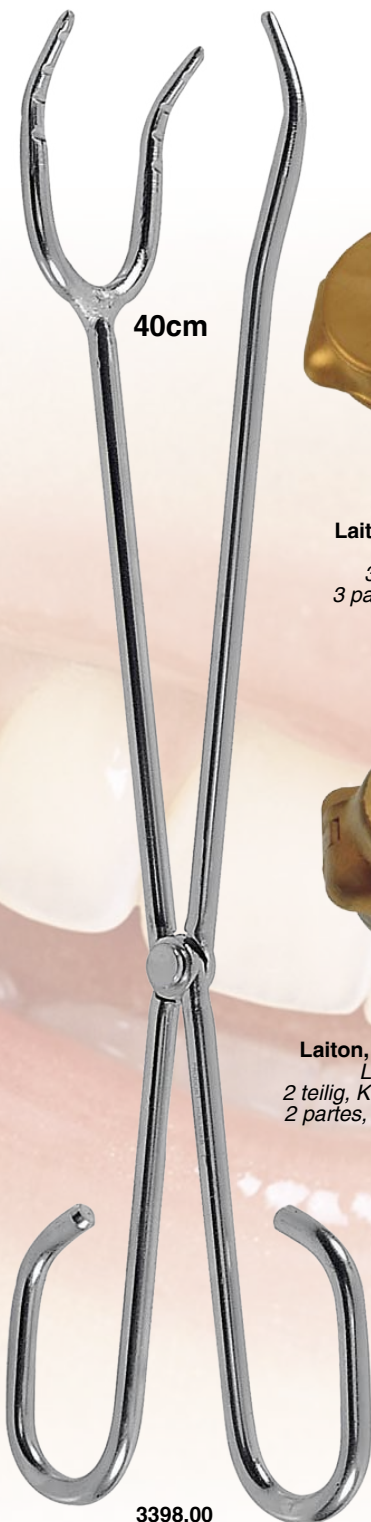

3398.00

Pince à moufle

Crucible tongs extra long denture flask / Küvetten Zange / Tenazas para muflas



1742.03

111x80x50mm

Laiton, clavettes 3 parties

Lock pins 3 parts
3 teilig, Keilverschluß
3 partes, cierre con pasador



1742.04

11x80x59mm

Laiton, clavettes 3 parties

Lock pins 3 parts
3 teilig, Keilverschluß
3 partes, cierre con pasador



2018.00

60x36x50mm

Ovale, bridge avec extracteur

Oval, bridges with extractor
Ovale Brücken, Extraktions-Öffnung
Oval, con extractor



4232.00

110x65x55mm

Laiton, clavettes 2 parties extracteur

Lock pins 2 parts extractor
2 teilig, Keilverschluss Extraktions-Öffnung
2 partes, con extractor y cierre de pasador



1934.00

2 clavettes / 2 lock pins
Keilverschluß / pasador



2257.00

Extracteur / extractor
Extraktions Öffnung / extractor

Ref.	€ HT
1742.03	230,96
1742.04	237,96
1777.00	75,02
1934.00	31,90
2018.00	73,20
2257.00	9,80
3398.00	80,84
4232.00	213,03
4500.01	173,67
4500.02	173,67
4502.00	110,33
4502.05	13,05
4505.01	225,23
4505.03	225,23

Jusqu'à épuisement des stocks
Until the end of stocks / So langer der Vorrat
reicht / Hasta el final del existencia



4502.00

Holy, inox, écrous à oreilles
Stainless steel press, flat screws
Küvettenbügel aus Edelstahl
Inoxidable, tuercas planas



4500.01

Standard, 1 moufle
1 flask / 1 Küvette
1 mufla



4500.02

Standard, 2 moufle2
2 flasks / 2 Küvetten
2 muflas



4505.01

Ressort & plateau, 1 moufle
Spring & plate, 1 flask
Druckfeder & Platte 1 Küvette
Muelle y platillo 1 mufla



4505.03

Ressort & plateau, 3 moufles
Spring & plate, 3 flasks
Druckfeder & Platte 3 Küvetten
Muelle y platillo 3 muflas



1718.00
Marteau, 21,5cm , tête 60mm
Hammer / Martillo

1701.02
Manche / Handle
Heft / Mango

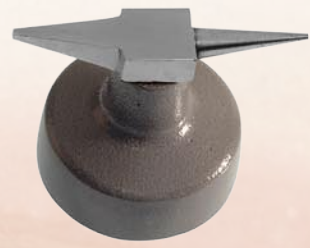

1589.00
Bigorne Holy
Beak irons
Ambösschen
Bigornia



FORMABRILL
46/16052

Ref.	€ HT
1589.00	87,42
1701.02	9,44
1718.00	49,65
2077.00	4,35
3605.00	40,53
FT46/16052	24,29



3605.00
Lampe à alcool
Alcohol lamp
Alkohollampe
Mechero de alcohol

Idéal pour les modèles en résine et les métaux précieux
Ideal for resin models and noble metals
Ideal für Modelle aus Kunststoff und Edelmetalle
Ideal para los modelos en resina y metales nobles

2077.00
Mèche pour Lampe à alcool (au mètre)
Wick of Alcohol lamp (1 meter)
Docht für Alkohollampe (pro Meter)
Mecha para Lamparilla de alcohol (el metro)



1704.03
Manche burins, échoppes, grattoirs
Chisels, scrapers Handle
Stichel Heft
Mango para buriles de grabador y rascadores

1693.20
Manche pour lime 160 à 200mm
Files Handle
Heft für Feilen
Mango para limas

Ref.	€ HT
1654.04	28,50
1654.05	28,50
1654.06	28,50
1656.06	32,25
1683.04	44,35
1683.05	58,77
1693.20	1,91
1704.03	5,10
2086.02 ▲	24,00
2086.03 ●	24,00
2086.04 ◐	24,00
2086.06 ▬	24,00
2086.07 ●	24,00
2086.09 ●	24,00
2086.10 ▬	24,00
2086.11 ●	24,00
2086.12 ●	24,00
3605.00	40,53



1654.xx
Ciseau plat / Flat chisel
Flachstichel / Cincel llano



1656.06
Onglette plate mince 6mm
Ungula chisel thin
Kautschuckstichel, flach
Uneta llana fina



1683.xx
Limes VALLORBE 1/2 ronde
Files Switzerland 1/2 round
Feilen 1/2 Rund / Limas 1/2 redondas



Limes aiguilles
Needle files / Nadelfeilen / Limas agujas
2086.xx



1594.00
Boc fils / Saw frame
Laubsägebogen / Sierra

Jusqu'à épuisement des stocks
Until the end of stocks / So langer der Vorrat reicht /
Hasta el final del existencia

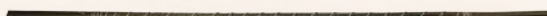

1594.02
12 Lames / blades
Sägeklingen / Cuchillas



3030.00
Scie de poche / Pocket saw
Klappsäge / Sierra de bolsillo

3030.01
12 Lames / blades
Sägeklingen / Cuchillas

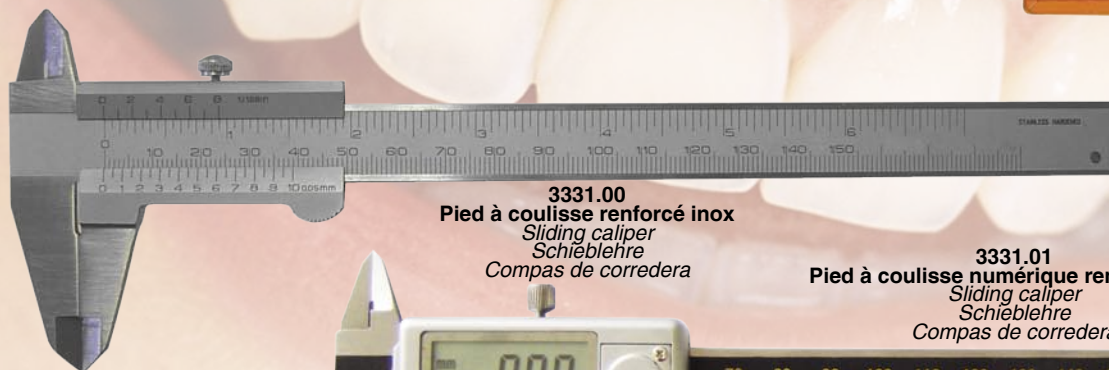

3331.00
Pied à coulisse renforcé inox
Sliding caliper
Schieblehre
Compas de corredera

3331.01
Pied à coulisse numérique renforcé inox
Sliding caliper
Schieblehre
Compas de corredera



Ref.	€ HT
1594.00	35,90
1594.02	6,05
3030.00	17,08
3030.01	16,13
3331.00	39,70
3331.01	70,97
3333.00	25,04
3333.01	37,13
3334.00	28,90



3334.00
Compas d'épaisseur IWANSON
Thickness compass
Tasterzirkel / Compas



3333.00
Compas 11cm
Compass
Tasterzirkel
Compas



3333.01
Compas 8cm
Compass
Tasterzirkel
Compas

Moules préformes

Mould for teeth - Silikon-Form - Molde para preformas

Les moules préformes permettent de façonner en une seule coulée de cire la face triturante des molaires et prémolaires haut et bas, en 3 tailles : petit, moyen et grand modèle. Le moule pour préforme occlusale Prodont-Holliger procure un gain de temps important pour la sculpture, les couronnes, les bridges, etc...

It makes it possible to work in only one cast of wax the triturating face of the molars and premolars high and low, in 3 sizes: small, average and great model. The mould for teeth Prodont-Holliger gets an important time-saver for the sculpture, the crowns, the bridges, etc...

Diese Silikon-Form erlaubt obere und untere Backenzähne und Prämolaren in drei verschiedenen Größen in einem Wachsgang zu gießen. Diese Form präsentiert einen wichtigen Zeitgewinn und Hilfe für Skulptur, Kronen und Brücken

Permite trabajar en un solo vaciado de cera la cara triturante de molares y premolares, tanto superiores e inferiores, en 3 tamaños: molares de pequeño, mediano y grande. El molde para preformas dentales Prodont-Holliger facilita un ahorro de tiempo importante a la hora de esculpir coronas, puentes, etc...

Ref.	€HT
44/100AC	68,96

Moule en silicone, blanc, dents numérotées, 14cm de diamètre.

*Mould out of white silicon, numbered teeth, diameter 14 cm.
Weisse Form aus Silikon, nummerierte Zähne, Durchmesser 14 cm.
Molde en silicona blanco, dientes numerados, 14 cm diámetro.*

52 Préformes
Shapes
Formen
Preformas



Obtenez les incisives, molaires et prémolaires pour armatures métallique sur support céramique en une seule coulée de cire. (28 préformes)

Mould for teeth on metallic framework: Get incisors, molars and premolars for metallic framework on ceramic, in only one cast of wax. (28 shapes)

Silikon-Zahnform für Wachszwischenglieder : Ein wichtiger Zeitgewinn bringt Ihnen diese Form : Sie können in einem Wachsguss Wachszwischenglieder zur Herstellung von Front – und Seitenzahnbrücken für die Verblendungstechnik mit Keramik oder Kunststoff fertigen. (obere und untere Schneidezähne, Prämolaren und Molaren). **(28 Formen)**

Molde para preformas: Incisivos, molares and premolares para soporte metálico sobre cerámica. (28 preformas)

Ref.	€HT
44/101AC	51,98

28 Préformes
Shapes
Formen
Preformas



Moules souples à empreintes

Flexible tray base - Modellsockelformen - Moldes flexibles a huella

Inférieurs

Lower models / Unterkiefer / Inferiores

LOT DE 6

Set of 6 / Set mit 6 / Estuche de 6

Supérieurs

Upper models / Oberkiefer / Superiores

Ref.	€HT
45/106	41,38

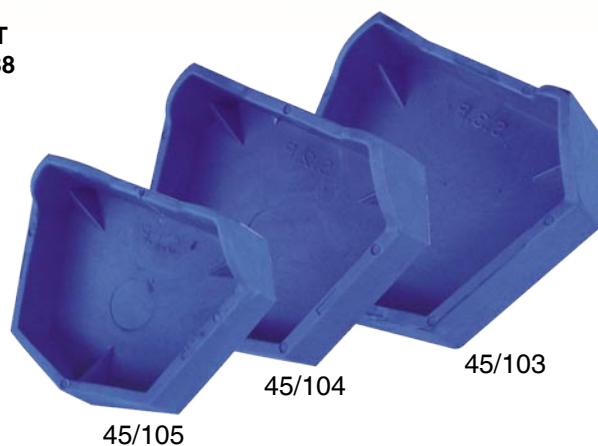
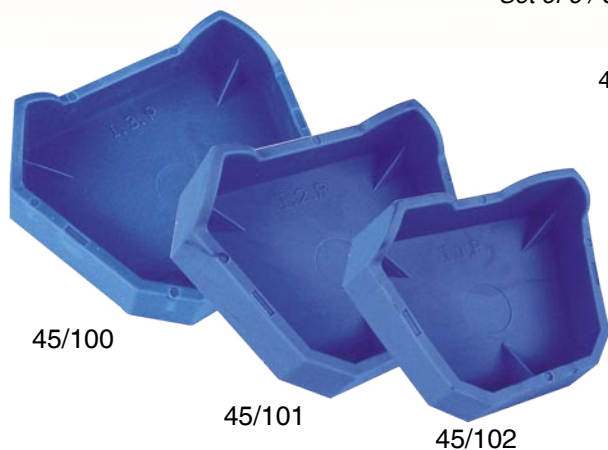

INSTRUMENTS

Accessoires - Verschiedenes Zubehör - Accesorios



19,5x8,5cm

Conditionnement 1Kg ou 500g

1kg CP1620.10
500g CP1620.05

Cire à modeler Prima été, plaques

*Modelling wax Prima summer, sheets
Modellierwachs Prima Sommer, Platten
Ceras para modelar Prima verano, placas*

 Fusion: 68°C - 74°C



19,5x8,5cm

1kg CP1621.10
500g CP1621.05

Cire à modeler Prima hiver, plaques

*Modelling wax Prima winter, sheets
Modellierwachs Prima Winter, Platten
Ceras para modelar Prima invierno, placas*

 Fusion: 68°C - 74°C



19,5x8,5cm

1kg CP1641.10
500g CP1641.05

Cire à modeler Spéciale rouge, plaques

*Modelling wax Special Red, sheets
Modellierwachs Spezial Rot, Platten
Ceras para modelar Especial roja, placas*

 Fusion: 72°C - 76°C



19,5x8,5cm

1kg CP1651.10
500g CP1651.05

Cire à modeler Standard 2, plaques

*Modelling wax Standard 2, sheets
Modellierwachs Standard 2, Platten
Ceras para modelar Standard 2, placas*

 Fusion: 65°C - 76°C



19,5x8,5cm

1kg CP1661.10
500g CP1661.05

Cire à modeler ultra souple

*Modelling wax, ultra flexible
Modellierwachs, halbfestem
Ceras para modelar, flexibles*

 Fusion: 61°C - 71°C

Ref.	€ HT
CP1661.05	22,49
CP1620.05	22,49
CP1620.10	44,13
CP1621.05	22,49
CP1621.10	44,13
CP1641.05	22,49
CP1641.10	44,13
CP1651.05	22,49
CP1651.10	44,13
CP1661.10	44,13

Cires à mordu
Bite Wax - Bissnehmewachs - Cera para morder

Cires
 Wax - Wachse - Ceras



CP1680
 x50 pcs.



CP1680D
 x50 pcs.
hard / hart / dura



CP1667.01
Cire molle pour articulation
 60 bâtons de 14,5cmx1
Bite wax, 60 sticks
Modellierwachs, 60 Stangen
Cera para articulaciones, 60 barras



CP1670
Cire collante
 12 bâtons de 10cmx1cm
Sticky wax, 12 sticks
Klebewachs, 12 Stangen
Cera adherente, 12 barras

 *Ramollissement: 70°C - 90°C*
Liquéfaction: 100°C
Embrassement: 180°C



CP1690R
Pain à sculpter, 100g, 7x5x3cm
Carving wax / Modellier Block / Pastilla para esculpir

Ref.	€ HT
CP1667.01	39,68
CP1670	15,91
CP1690R	8,06
CP1680	20,90
CP1680D	20,90

Disques Zircon Zirconia - Zirkon - Zircono

ABRASIFS



REFERENCE	2203Z	2205Z	2215Z
TAILLE / size mm Ø x épaisseur <i>thickness / Dicke / Espesor</i>	22 x 0,3	22 x 0,5	22 x 1,5
VITESSE MAX. RPM	15000	15000	15000
QUANTITÉ <i>Quantity / Packungseinheit / Cantidad per caja</i>	1	1	1
€ HT	22,15	22,15	24,51

Disques Abrasifs ultra fins pour céramique et métal

Slim Abrasives for ceramics and metals
Schleifinstrumente - extra dünne für Keramik und Metall
Abrasivos ultra finos para cerámica y todos los metales



REFERENCE	220202S	2202012	2202014	2202412	2202612	2202614
TAILLE / size mm Ø x épaisseur <i>thickness / Dicke / Espesor</i>	22 x 0,2	22 x 0,2	22 x 0,2	22 x 0,24	22 x 0,26	22 x 0,26
VITESSE MAX. RPM	15000	15000	15000	15000	15000	15000
QUANTITÉ <i>Quantity / Packungseinheit / Cantidad per caja</i>	100	100	25	100	100	25
€ HT	39,68	39,36	12,84	34,69	34,69	10,40



Ne laisse aucune trace sur la céramique

Non-contaminating
hinter-lässt keine Spuren auf der Keramik
No deja marcas sobre la cerámica



REFERENCE	2203012	2203014
TAILLE / size mm Ø x épaisseur <i>thickness / Dicke / Espesor</i>	22 x 0,3	22 x 0,3
VITESSE MAX. RPM	15000	15000
QUANTITÉ <i>Quantity / Packungseinheit / Cantidad per caja</i>	100	25
€ HT	34,69	10,40



Disques Abrasifs ultra fins pour métal (résine synthétique)
Slim Abrasives for metals (resin base) / Schleifinstrumente - extra dünne für Metall (Resin)
Abrasivos ultra finos para todos los metales (resinas sinteticas)



REFERENCE	22030D	25030D
TAILLE / size mm Ø x épaisseur <i>thickness / Dicke / Espesor</i>	22 x 0,3	25 x 0,3
VITESSE MAX. RPM	15000	15000
QUANTITÉ <i>Quantity / Packungseinheit /</i> <i>Cantidad per caja</i>	100	100
€ HT	34,69	38,19

ABRASIFS

Disques à séparer ultra fins renforcés
Slim reinforced separating discs / Extra-dünne glasfaserverstärkte Trennscheiben
Discos a separar ultra finos reforzados



pour céramique / **pour métal**
for ceramics / für Keramik / para cerámica for metals / für Metall / para todos los metales

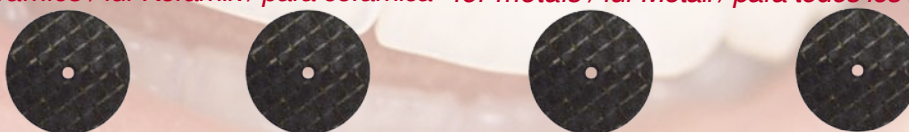

REFERENCE	2502R	2503R
TAILLE / size mm Ø x épaisseur <i>thickness / Dicke / Espesor</i>	25 x 0,2	25 x 0,3
VITESSE MAX. RPM	10000	10000
QUANTITÉ <i>Quantity / Packungseinheit /</i> <i>Cantidad per caja</i>	20	20
€ HT	35,86	35,86

REFERENCE	2502RC	2503RC
TAILLE / size mm Ø x épaisseur <i>thickness / Dicke / Espesor</i>	25 x 0,2	25 x 0,3
VITESSE MAX. RPM	10000	10000
QUANTITÉ <i>Quantity / Packungseinheit /</i> <i>Cantidad per caja</i>	20	20
€ HT	35,86	35,86

Disques diamantés Extra souples Extra fins
Flexible diamond discs / Trennscheiben flexibel diamond
Discos flexibles diamond

REFERENCE	2510R	2510F
TAILLE / size mm Ø x épaisseur <i>thickness / Dicke / Espesor</i>	22 x 0,3	22 x 0,15
VITESSE MAX. RPM	20000	15000
QUANTITÉ <i>Quantity / Packungseinheit /</i> <i>Cantidad per caja</i>	1	1
€ HT	28,11	42,38

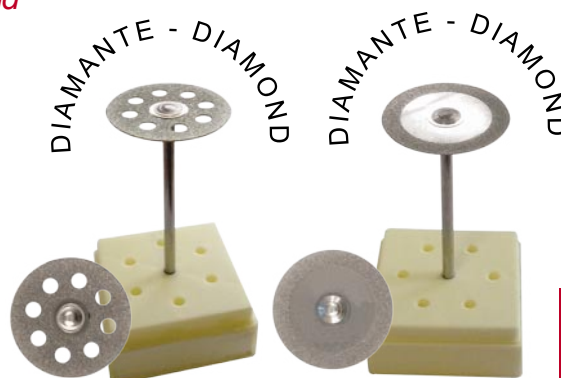

Disques à tronçonner pour métal
 Cut off wheels for metals
 Trennscheiben für Metall
 Discos de cortar para todos los metales

ABRASIFS

HAUTE VITESSE
 HIGH SPEED

Fin
 Thin
 Dünne
 Fino

Moyen
 Medium
 Mittel
 Mediano

Gros
 Coarse
 Dick
 Grueso



REFERENCE	2206011	2505011	3707011	3710011	3717011
TAILLE / size mm Ø x épaisseur thickness / Dicke / Espesor	22 x 0,6	25 x 0,5	37 x 0,7	37 x 1	37 x 1,7
VITESSE MAX. RPM	10000	10000	10000	20000	20000
QUANTITÉ Quantity / Packungseinheit / Cantidad per caja	100	100	100	100	100
€ HT	25,36	25,57	49,97	57,08	41,91



Résistance & longévité
 Strength & Longevity
 Resistenz & Standfestigkeit
 Resistencia y durabilidad

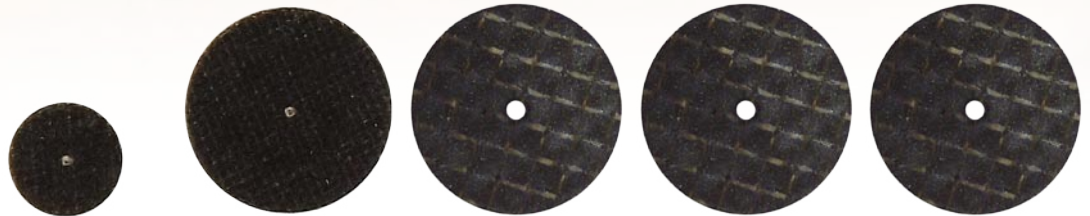
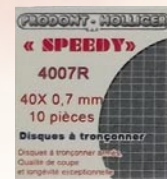

REFERENCE	2201R	4001R	4005R	4007R	4020R
TAILLE / size mm Ø x épaisseur thickness / Dicke / Espesor	22 x 1	40 x 1	40 x 0,5	40 x 0,7	40 x 1
VITESSE MAX. RPM	38000	38000	38000	38000	38000
QUANTITÉ Quantity / Packungseinheit / Cantidad per caja	50	10	10	10	20
€ HT	56,33	20,69	25,25	25,25	36,92

Disques à séparer ultra fins pour métal
 Slim separating discs for metals
 Extra-dünne Trennscheiben für Metall
 Discos a separar ultra finos para todos los metales

plat 1 face
 Flat safe side
 Einseitig schneidend
 Planos 1 cara



plat 2 faces
 Flat 2 sides
 Beidseitig schneiden
 Planos 2 caras



convexe/concave
 Convex/concave
 Konvex/Konkav
 Copa/convex



REFERENCE	2206010	2206020	2206050
TAILLE / size mm Ø x épaisseur <i>thickness / Dicke / Espesor</i>	22 x 0,6	22 x 0,6	22 x 0,6
VITESSE MAX. RPM	25000	25000	10000
QUANTITÉ <i>Quantity / Packungseinheit / Cantidad per caja</i>	100	100	100
€ HT	24,08	26,42	52,30



Meulettes à dégrossir
 Grinding wheels
 Schleifräder
 Muelas de cortar



REFERENCE	2230011	3730011
TAILLE / size mm Ø x épaisseur <i>thickness / Dicke / Espesor</i>	22 x 3	37 x 3
VITESSE MAX. RPM	10000	10000
QUANTITÉ <i>Quantity / Packungseinheit / Cantidad per caja</i>	25	25
€ HT	30,02	46,26

BACS à ULTRASONS / Ultrasonic Cleaner

HYGIENE panneau de contrôle Aluminium
SILENCIEUX grâce à son couvercle en PEHD
 Structure inox / garantie 2 ans
 Interrupteur d'allumage étanche et renforcé

HYGIENIC: Aluminum control panel
SILENT: PEHD cover
 Stainless steel Structure / 2 years guarantee
 Waterproof switch

MATERIEL

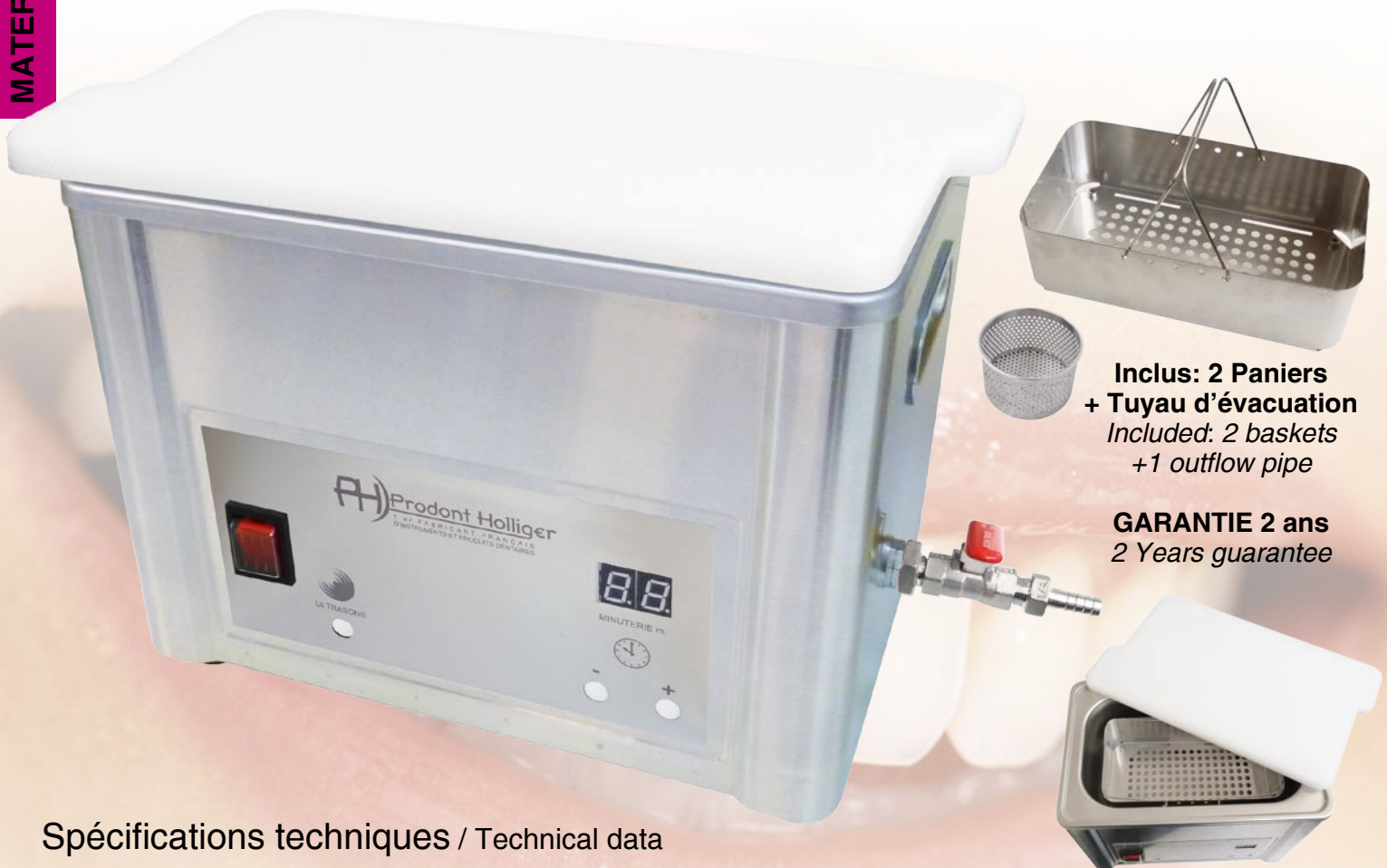

**Inclus: 2 Paniers
 + Tuyau d'évacuation**
*Included: 2 baskets
 +1 outflow pipe*

**GARANTIE 2 ans
 2 Years guarantee**

Spécifications techniques / Technical data

Type	Volume	Fréquence / Frequency	Puissance des ultrasons / Ultrasonic power	Puissance de chauffe / Heating power	Minuterie / Time setting (Min)	Température
PH300N	3L	40 KHz	120W	-	1-99	-
PH300CN				150W		20-60 / 68-140°F
PH500N	5L			-		-
PH500CN				150W		20-60 / 68-140°F

3L

Dimensions:
 Cuve / vat: 20x11x5cm
 Dim. Externes (hors robinet)
 External (w/o drain valve)
 128xL18xH21cm

sans Fonction Chauffe / without Heater

Ref. €HT
 PH300N 648,90

avec Fonction Chauffe / with Heater

Ref. €HT
 PH300CN 772,50

5L

Dimensions:
 Cuve / vat: 20x11x9cm
 Dim. Externes (hors robinet)
 External (w/o drain valve)
 128xL18xH26cm

sans Fonction Chauffe / without Heater

Ref. €HT
 PH500N 854,90

avec Fonction Chauffe / with Heater

Ref. €HT
 PH500CN 1025,00

BACS A ULTRASONS de Laboratoire
 avec couvercle pour Becher suspendu
Protégez votre cuve à ultrasons
 Le couvercle en PEHD permet de mettre
 votre Becher en suspension
 en isolant votre cuve des projections corrosives.

ULTRASONIC CLEANER for Laboratory
 with lid for Becher
PROTECT your ultrasonic cleaner
 The lid can receive a Becher
 to isolate the tank from corrosive liquids.

MATERIEL



Spécifications techniques / Technical data

Type	Volume	Fréquence / Frequency	Puissance des ultrasons / Ultrasonic power	Puissance de chauffe / Heating power	Minuterie / Time setting (Min)	Température
PH300NB	3L	40 KHz	120W	-	1-99	-
PH300CNB				150W		20-60 / 68-140°F
PH500NB	5L			-		-
PH500CNB				150W		20-60 / 68-140°F

Dimensions:
 Cuve / vat: 20x11x5cm
 Dim. Externes (hors robinet)
 External (w/o drain valve)
 128xL18xH21cm

3L

avec Fonction Chauffe
 Ref. € HT
 PH300CNB 870,35

sans Fonction Chauffe
 Ref. € HT
 PH300NB 736,45

Dimensions:
 Cuve / vat: 20x11x9cm
 Dim. Externes (hors robinet)
 External (w/o drain valve)
 128xL18xH26cm

5L

avec Fonction Chauffe
 Ref. € HT
 PH500CNB 1148,45

sans Fonction Chauffe
 Ref. € HT
 PH500NB 1024,85

**Inclus: 1 Becher
 2 Paniers
 + Tuyau d'évacuation**

GARANTIE 2 ANS

Included
 -1 Becher
 -2 baskets
 -flexible outflow pipe
2 YEARS guarantee

1300°C
2000°F



⊖ 25-35mm

Le STYLOFLAM est un chalumeau de poche (16 cm de long) à allumage piezo. Il se recharge comme un briquet avec les cartouches de gaz Miniflam 400ml 47/1602. (vendues séparément).

The STYLOFLAM is a pocket torch (16 cm long) with automatic ignition. It's rechargeable as a lighter with Miniflam gas 400ml 47/1602. (sold seperately).

Der Styloflam ist ein Miniatur-Taschen-Schweißgerät (16 cm) mit automatischer Zündung. Er ist wieder auffüllbar wie ein Feuerzeug anhand unserer 400ml Gasflaschen (47/1602).

El Styloflam es un pequeno mechero de bolsillo con encendido piezo. Se recarga como un encendedor con las botellas de gas Miniflam 400ml (47/1602).

Ref.	€ HT
FU48/2000	145,34

ATTENTION: pour garantir une utilisation et une durée de vie optimales, recharger nos brûleurs UNIQUEMENT avec le gaz MINIFLAM 400ml ref. 47/1602 (mélange butane/propane spécialement étudié et purifié).

CAUTION: refill our burners with specifically designed Miniflam gas cartridge 47/1602 ONLY

ACHTUNG : Zur optimalen Benutzung unserer Brenner und um eine lange Lebensdauer zu garantieren, nur mit unserem MINIFLAM Gas, in 400 ml Flasche, Art.-N° 47/1602, aufladen. (Miniflam Spezial-Mischung Butan/Propan, von hoher Reinheit)

CUIDADO : Para garantizar un uso y una duración de vida optima, recarguen nuestros sopletes UNICAMENTE con el gas MINIFLAM 400 ml (cod. 47/1602). Mezcla de butano/propano especialmente concebida y purificada.



PROTORCH3

ALLUMAGE AUX NOUVELLES NORMES CE: SÉCURITÉ GARANTIE!

Ce chalumeau délivre une flamme précise et réglable pouvant atteindre 1300°C. Très simple à allumer grâce au système piezo, son autonomie de 60mn environ en continu permet de travailler en toute liberté.

ATTENTION: pour garantir une utilisation et une durée de vie optimales, recharger le Protorch3 UNIQUEMENT avec le gaz MINIFLAM 400ml ref. 47/1602 (mélange butane/propane spécialement étudié et purifié).

This blowtorch delivers a precise and adjustable flame able to reach 1300°C. Very simple to light thanks to the piezo system, its autonomy of 60mn approximately uninterrupted makes it possible to work with complete freedom.

CAUTION: refill with Miniflam gas cartridge 47/1602 ONLY

Dieser Schweißbrenner gibt eine präzise und regulierbare Flamme, die bis 1300°C erreichen kann. Sehr einfach zu zünden dank dem automatischen Zündsystems „Piezo“. Durch seine ununterbrochene Autonomie bis zu 60 Min erlaubt er komplett unabhängig zu arbeiten. Der Protorch3 ist wiederaufladbar mit der Gaspatrone Miniflam 400ml (47/1602).

Este soplete da una llama precisa y ajustable que puede alcanzar 1300°C. Muy sencillo de encender gracias al sistema de encendido automático "piezo", y con una autonomía de 60 minutos ininterrumpidas, permite trabajar con total libertad. Se recarga con el cartucho de gas Miniflam 400 ml (47/1602).



Ref. € HT
FU31/0403 69,91





2750°C
5000° F

	Ref.	€ HT
Gaz naturel / Natural gas / Erd gas	FU37/0562	235,87
Butane, propane	FU37/0572	235,87

Accessoires / Accessories / Verschiedenes Zubehör / Accesorios
 37/0580 Coupelle à cire / Wax cup / Wachsschale / Copela para cera
 37/1300 Tétine Butane, propane 14mm / Adapter / Adaptador
 37/1301 Tétine gaz naturel 22mm / Adapter / Adaptador

Le bec bunsen Laboflam allie l'esthétique à l'utile et sera un signe de qualité sur tout comptoir. Il se branche sur le gaz de ville ou une bouteille butane/propane. Il comporte une flamme pilote brûlant en continu.

The Bunsen burner Laboflam combines beauty and usefulness. It connects to the city gas or a butane/propane tank. A burning pilot flame burns continually.

Der Bunsenbrenner Laboflam vereinigt Ästhetik und das Nützliche. Er wird an Stadtgas oder Butan/Propan Gasflaschen angeschlossen. Er ist manuell zündbar und mit einer Sparflamme ausgestattet.

El mechero Laboflam combina la elegancia con la utilidad. Se conecta al gas ciudad o las botellas de butano/propano. Tiene un piloto de llama.

Brûleurs Nomades

Nomad Burners - Nomanden-Brenner - Quemadores nómados

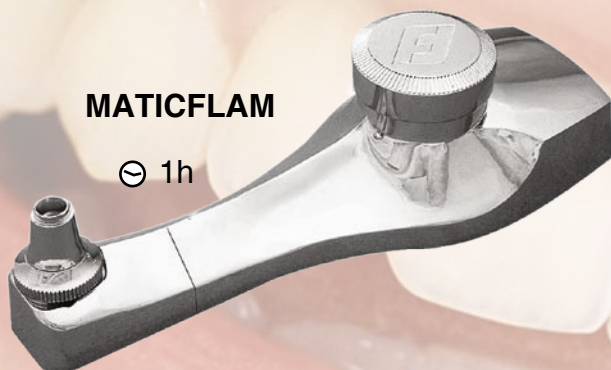

MATICFLAM

⊖ 1h



FU37/0580

Jusqu'à épuisement des stocks
Until the end of stocks / So langer der Vorrat reicht / Hasta el final del existencia

Ref.	€ HT
FU38/0651	263,74
FU37/0580	24,40

Le Maticflam s'allume d'une simple pression de la main sur le bouton d'allumage électronique et se recharge comme un briquet avec le gaz Miniflam 400ml (47/1602).

The Maticflam is lit by pressure applied on the electronic button and is rechargeable as a lighter with Miniflam 400ml gas (47/1602).

Der Maticflam : automatisches Zünden durch einfachen Hand-Druck auf den Einstell-Knopf. Einfaches Nachfüllen des Brenners wie ein Feuerzeug mit Miniflam Gas 400ml (47/1602).

El Maticflam puede ser encendido sencillamente presionado un botón de encendido automático. Recargable como un encendedor con las botellas de gas Miniflam 400ml (47/1602).

La puissance d'un brûleur partout où vous en avez besoin

HOLY Nomade

Réglage indépendant de la flamme et de la veilleuse.

Independent flame and pilot flame settings.

Individuelles Einstellen der Flamme und der Spartflamme.

Arreglo individual des quemador y de la vigilante.

Vendu sans cartouche de gaz - Gas cartridge sold separately.
(Ref. 47/1621)



AUTONOMIE
Flamme / Flame: 1h
Veilleuse / Pilot: 2h

Ref.	€ HT
FU37/1195	112,99



INCLUS:
 37/1300 Adaptateur Butane, propane 14mm / Adapter / Adaptador
 37/1301 Adaptateur gaz naturel 22mm / Adapter / Adaptador

Ref.	€ HT	Manuel
FU37/1182	123,29	Butane, 30mB, 28 Th ●
FU37/1192	123,29	Naturel/Erd, 20mB, 16,5 Th ●
FU37/1202	123,29	Propane, 37mB, 23,5 Th ●

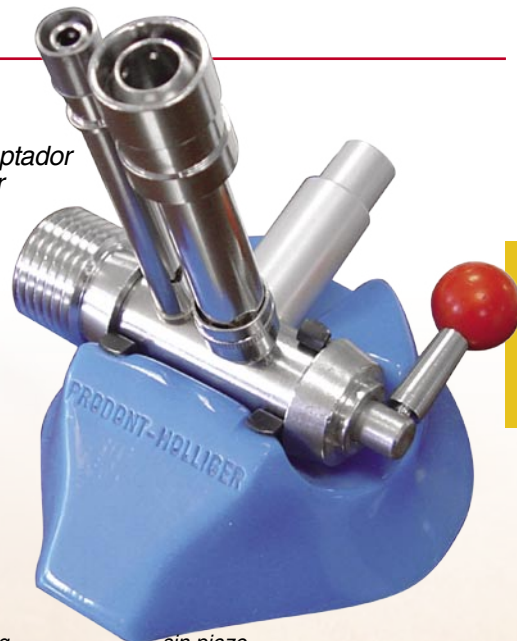

FLAMME

- Allumage manuel
- Diffuseur spécial donnant un dard très chaud
- Embout fileté, raccord à vis
- Flamme ou veilleuse à commande instantanée
- 2 positions de travail
- Veilleuse aérée
- Bague de réglage d'admission d'air
- Démontable
- Surbaissé, stable, antidérapant

- Manual ignition
- Special diffuser for a high temperature flame
- Threaded gas connection
- 2 working positions
- Pilot flame chimney aerated
- Ring to adjust air flow
- All parts removable
- Extra low, stable, antiskid

- ohne Piezo-Zündung
- Spezielle Düse für eine sehr heiße Flamme
- Brenner für Anschlussschlauch mit Gewinde
- Flamme oder Sparflamme kurz zündbar
- 2 Arbeitspositionen
- Ventilierte Sparflamme
- Regulierungsbuchse für Luftzufuhr
- Brenner zur Reinigung zerlegbar
- Extra flach gehalten, stabil und rutschfest

- sin piezo
- Difusor especial que permite una llama muy caliente
- Conexion por manguito de union
- Llama o piloto con mando instantáneo
- 2 posiciones de trabajo
- Piloto ventilado
- Anillo para ajustar el flujo de aire
- Desmontable
- Mechero extra bajo, estable y antideslizante

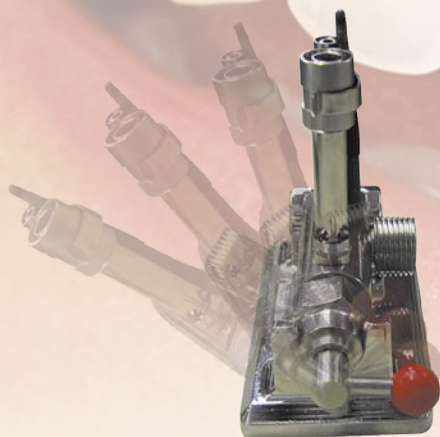

Ref.	€ HT	2 positions
FU37/1182TC	202,91	Butane, 30mB, 28 Th ●
FU37/1192TC	202,91	Naturel/Erd, 20mB, 16,5 Th ●
FU37/1202TC	202,91	Propane, 37mB, 23,5 Th ●

Orientation libre / Freely adjustable / Orientierbares / Orientable

FU37/3182TC	217,33	Butane, 30mB, 28 Th ●
FU37/3192TC	217,33	Naturel/Erd, 20mB, 16,5 Th ●
FU37/3202TC	217,33	Propane, 37mB, 23,5 Th ●

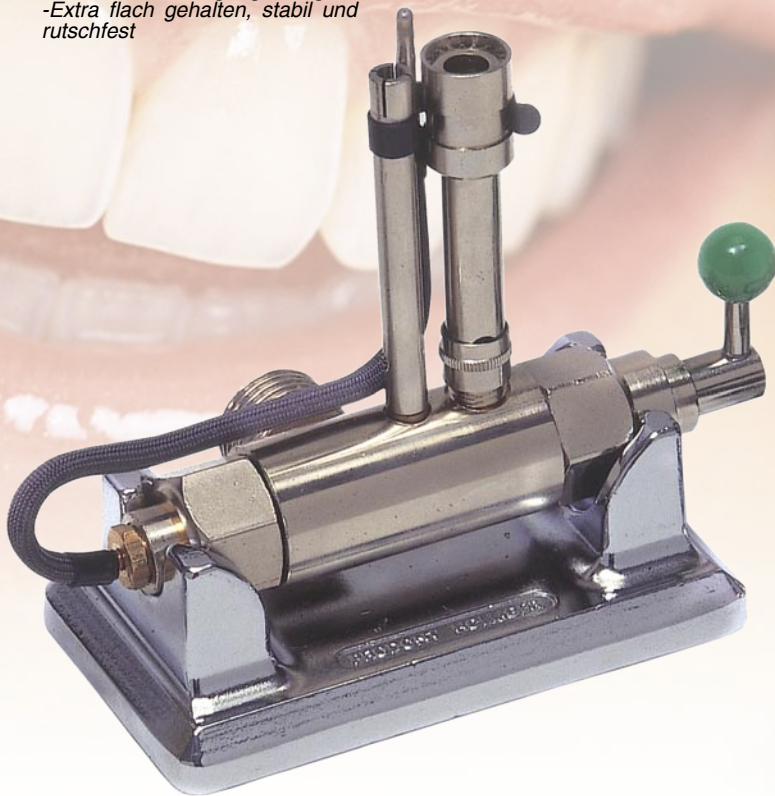

Accessoires / Accessories / Verschiedenes Zubehör / Accesorios
 37/1300 Tétine Butane, propane 14mm / Adapter / Adaptador
 37/1301 Tétine gaz naturel 22mm / Adapter / Adaptador

- Allumage manuel
- Diffuseur spécial donnant un dard très chaud
- Embout fileté, raccord à vis
- Flamme ou veilleuse à commande instantanée
- 2 positions de travail
- Veilleuse aérée
- Bague de réglage d'admission d'air
- Démontable
- Sécurité coupant le gaz dans les 40s en cas d'extinction accidentelle.

- Manual ignition
- Special diffuser for a high temperature flame
- Threaded gas connection
- 2 working positions
- Pilot flame chimney aerated
- Ring to adjust air flow
- All parts removable
- Security cuts the gas flow within 40s in case it extinguishes accidentally.

- ohne Piezo-Zündung
- Spezielle Düse für eine sehr heiße Flamme
- Brenner für Anschlussschlauch mit Gewinde
- Flamme oder Sparflamme kurz zündbar
- 2 Arbeitspositionen
- Ventilierte Sparflamme
- Regulierungsbuchse für Luftzufuhr
- Brenner zerlegbar
- Züandsicherung unterbricht die Gaszufuhr innerhalb von 40s, falls die Flamme des Brenners versehentlich erlöscht.

- sin piezo
- Difusor especial que permite una llama muy caliente
- Conexion por manguito de union
- Llama o piloto con mando instantáneo
- 2 posiciones de trabajo
- Piloto ventilado
- Anillo para ajustar el flujo de aire
- Desmontable
- Sistema de seguridad que cerra el gas en 40s si la llama se apaga por accidente.

Têtes de chalumeaux + Gaz GP

Torch heads+GP Gas -Schweißköpfe+GP Gas - Cabezas de mecheros+GP gas

FLAMME

1200°C
1875° F



Tête Miniflam + Cartouche gaz, sous blister

Miniflam head + Gas cartridge, blister card
Miniflam Schweißköpfe + Einweg-Gasflasche, Blister Packung
Cabezas Miniflam + Botella de gas

Ref.	€ HT		
FU32/0300	50,60	Cartouche de gaz + tête A (4h) ⊖	allumage manuel
FU32/0302	47,20	Cartouche de gaz + tête B (3h30) ⊖	allumage manuel
FU32/0316	82,96	Cartouche de gaz + tête AP (4h) ⊖	allumage piezo
FU32/0318	95,79	Cartouche de gaz + tête BP (4h) ⊖	allumage piezo
FU32/0322	87,16	Cartouche de gaz + tête GFP (35mn) ⊖	grande flamme allumage piezo

Container rechargeable Ø 25mm ou Ø 38mm + Têtes

Rechargeable Container + head
Aufladbarer Container + Köpfe
Contenedor recargable + Cabezas

1200°C
1875° F

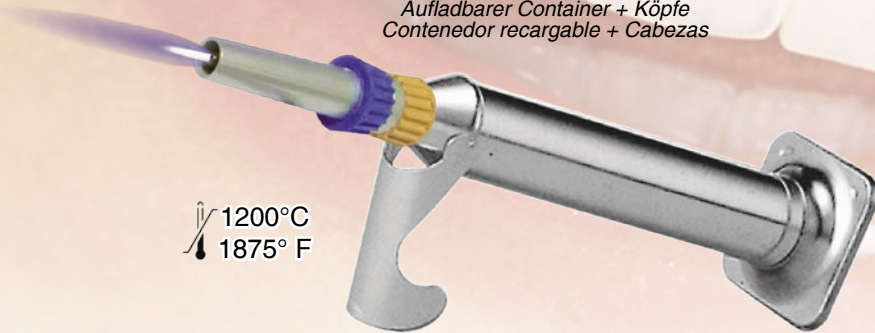

Ref.	€ HT		
FU31/0350	88,58	Container rechargeable + tête A (1h) ⊖	allumage manuel
FU31/0390	153,47	Container rechargeable + tête B (50mn) ⊖	allumage manuel
FU31/0351	116,59	Container rechargeable + tête AP (1h) ⊖	allumage piezo
FU31/0391	110,21	Container rechargeable + tête BP (50mn) ⊖	allumage piezo
FU31/0320	149,35	Container rechargeable + tête GFP (10mn) ⊖	grande flamme allumage piezo

Container rechargeable Ø 25mm ou Ø 38mm

Rechargeable Container
Aufladbarer Container
Contenedor recargable

51/0345
Ø 25mm



51/0346
Ø 38mm



Ref.	€ HT
FU51/0345	61,08
FU51/0346	61,32

Têtes de chalumeaux
Torch heads -Schweißköpfe - Cabezas de mecheros

1200°C
1875° F

FLAMME



A

33/0314

Allumage manuel, flamme très fine, ajustable

Manual ignition, very fine flame, adjustable
manuelles Zünden, sehr feine Flamme, regulierbar
Encendido manual, Llama muy fina, regulable



AP

33/0315

Allumage piezo, flamme très fine, ajustable

Piezo ignition, very fine flame, adjustable
automatische Zündung, sehr feine Flamme, regulierbar
Encendido automático, Llama muy fina, regulable



B

33/0325

Allumage manuel, flamme fine

Manual ignition, fine flame
Manuelles Zünden, feine Flamme
Encendido manual, Llama fina



BP

33/0326

Allumage piezo, flamme fine

Piezo ignition, fine flame
Automatische Zündung, feine Flamme
Encendido automático, Llama fina



GFP

33/0320

Allumage piezo, grande flamme

Piezo ignition, big flame
Automatische Zündung, grosse Flamme
Encendido piezo, grande Llama

Ref.	€ HT
FU33/0314	36,05
FU33/0315	60,67
FU33/0320	98,88
FU33/0325	33,48
FU33/0326	58,14

MICROTORCH EVOLUTIF
Microtorch Set

FLAMME



2750°C
5000°F

LA fine flamme de l'industrie
Stylo **léger et ergonomique**, maniement facile
Diamètre **réduit**
Tuyaux **ultra-flexibles** à base de silicone

Smallest flame of the industry
Easy and precise handling
Small diameter
Ultra-flexible tubing, silicon based

Sehr feine Flamme / Llama muy fina
Benutzungskomfort / Utilizacion comoda
Flexibel Schlauch-Set / Flexibles tubos



KIT de BASE / Starter Set



Ref. FU35/0378 € HT 186,43

Distributeur
Distributor
Kontrol Dosier-ventil
Distribuidor

Stylo+tuyaux
Pen+tubing
Brennerhandstück+Schlauch-Set
Pluma+tubos

Aiguilles 6/10+8/10
Needles
Nädel
Agujas

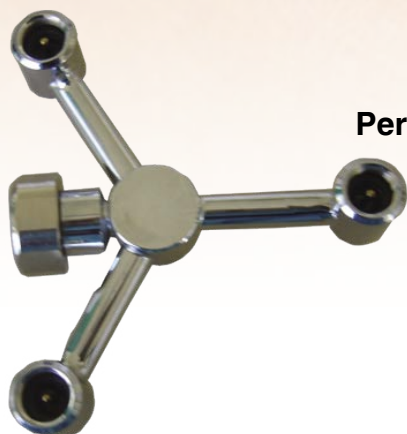

TRIOXY
Permet de raccorder 3 bouteilles d'oxygène
Connects 3 oxygen canisters
Adapter für 3 Sauerstoffflaschen
Adaptador para 3 oxigeno

Ref. FU35/0394 € HT 79,99

Les **adaptateurs** permettent de raccorder les **bouteilles industrielles** d'oxygène et de gaz à **200 bars** sur le distributeur.

ADAPTER (outside EU) *Connects to Standard Hoses 200 bars Tanks, Regulators...*



Ref. FU35/0376 € HT 37,08

Fonctionne également avec des bouteilles d'oxygène et de gaz **basse pression (10 bars)** pour plus de sécurité et de confort. Un container de gaz **rechargeable** peut remplacer la cartouche de gaz.

Gas and Oxygen (EU). Our specific low pressure bottles (10 bars) provides safety and comfort. The rechargeable canister can replace gas bottle.

FLAMME

Ref.	€ HT	
FU47/1601	123,29	Oxygène 1L / Oxygen / Sauerstoff / Oxigeno 12 pcs
FU47/1621	61,39	GP VAPOR GAZ 70ml / Gas 6 pcs



47/1601 47/1621

Les aiguilles se **fixent rapidement (1/4 de tour)**. Leur diamètre varie de **6/10 à 17/10** et délivrent la flamme la plus **fine** de l'industrie pour un **contrôle précis**.

NEEDLES: Fast assembly (1/4 turn). Diameter ranging from 6/10 to 17/10. The smallest flame of the industry for a precise control

Aiguilles

Needle - Lötdüse - Aguja

Ref.	€ HT	
FU36/0411	3,93	6/10
FU36/0412	3,93	8/10
FU36/0413	3,93	10/10
FU36/0414	3,93	12/10
FU36/0415	3,93	15/10
FU36/0416	3,93	17/10



Le support d'établi permet de **fixer** les bouteilles et de maintenir le stylo et les aiguilles pour un espace de travail **sécurisé et pratique**.

CLAMP

No bottles in the workspace. Features built-in pen holder

Bride support stylo+ tige-rallonge support aiguilles

*Pen stand Bridle+needle holder
Bügel+Nädelhalter
Brida+Porta-Agujas*

Ref.	€ HT
FU35/0377	60,79



⌚	1 Gaz	2 Oxygene
6/10	20h	7h
8/10	6h	1h30
10/10	4h	1h
12/10	1h30	0h30

MICROTORCH II



2750°C
5000° F

Ref. € HT
FU35/0372 261,83

Le Microtorch II, outil de précision par excellence, dispose d'un manomètre de contrôle d'oxygène. Il est prêt à l'emploi dans son coffret.

- 1 distributeur pour 1 cartouche GP Vapor (47/1621) et 2 Oxygène (47/1601)
- 1 manomètre
- 1 stylo Microtorch et son jeu de tuyaux
- 1 support de stylo
- 2 cartouches d'oxygène
- 2 aiguilles 6/10mm
- 2 aiguilles 8/10mm
- 1 aiguille 10/10mm
- 1 aiguille 12/10mm

The Microtorch II, above all a precision tool, has an oxygen control gauge and is ready to use in his kit.

- 1 distributor for 1 GP Vapor (47/1621) and 2 Oxygen (47/1601)
- 1 gauge
- 1 microtorch pen and its set of tubes
- 1 pen stand
- 2 oxygen canisters
- 2 6/10mm needle tips
- 2 8/10mm needle tips
- 1 10/10mm needle tip
- 1 12/10mm needle tip

Der Microtorch II, ein hervorragendes Präzisionswerkzeug das mit einem Sauerstoff-Kontroll-Manometer ausgestattet ist.

- Dazu ist er immer parat zur Hand und bereit zur Anwendung, in seinem handlichen, transportierbaren Koffer. Er erreicht eine Temperatur bis zu 2750 °C.
- 1 Verteilerplatte für 2 Sauerstoff-(47/1601) und 1 Gasflasche GP Vapor (47/1621)
- 1 Sauerstoff-Kontroll-Manometer
- 1 Brennerhandstück und Schlauch-Set
- 1 Halter für Brennerhandstück
- 2 Sauerstoff Flaschen
- 2 Lötösen 6/10mm
- 2 Lötösen 8/10mm
- 1 Lötösen 10/10mm
- 1 Lötösen 12/10mm

El Microtorch II, instrumento de precisión por excelencia, presenta las ventajas de tener un manómetro de registro del oxígeno, y de estar dispuesto al uso siempre en su maletín.

- 1 distribuidor para 1 gas GP Vapor (47/1621) y 2 oxígeno (47/1601)
- 1 manómetro de registro del oxígeno
- 1 pluma Microtorch y su juego de tubos
- 1 soporte para la pluma
- 2 botellas de oxígeno
- 2 agujas 6/10mm
- 2 agujas 8/10mm
- 1 aguja 10/10mm
- 1 aguja 12/10mm

MICROTORCH II+



2750°C
5000° F

Ref. € HT
FU35/0373 330,63

Le Microtorch II+, dispose d'un manomètre avec commande principale permettant de conserver les réglages.

- 1 distributeur pour 1 cartouche GP Vapor (47/1621) et 2 Oxygène (47/1601)
- 1 manomètre
- 1 stylo Microtorch et son jeu de tuyaux
- 1 support de stylo
- 2 cartouches d'oxygène
- 2 aiguilles 6/10mm
- 1 aiguille 8/10mm
- 2 aiguilles 10/10mm
- 1 aiguille 12/10mm

The Microtorch II+, has an oxygen control gauge with a main control which allows it to stay adjusted between uses.

- 1 distributor for 1 GP Vapor (47/1621) and 2 Oxygen (47/1601)
- 1 gauge
- 1 microtorch pen and its set of tubes
- 1 pen stand
- 2 oxygen canisters
- 2 6/10mm needle tips
- 1 8/10mm needle tip
- 2 10/10mm needle tips
- 1 12/10mm needle tip

Microtorch II+ mit zentralem Dosierventil zur schnellen und permanenten Flammen-Regulierung. Dadurch sparsamer Verbrauch von Gas und Sauerstoff. Temperatur bis zu 2750°C Im attraktiven Karton-Koffer.

- Ausgestattet mit :
- 1 zentrales Kontroll-Dosierventil für 2 Sauerstoff - (47/1601) und 1 Gasflasche GP Vapor (47/1621)
- 1 Sauerstoff- Kontroll-Manometer
- 1 Brennerhandstück und Schlauch-Set
- 1 Halter für Brennerhandstück
- 2 Sauerstoff Flaschen
- 2 Lötösen 6/10mm
- 1 Lötösen 8/10mm
- 2 Lötösen 10/10mm
- 1 Lötösen 12/10mm

El Microtorch II, presenta las ventajas de tener un manómetro de registro principal.

- 1 distribuidor para 1 botella de gas GP Vapor (47/1621) y 2 de oxígeno (47/1601)
- 1 manómetro principal
- 1 pluma Microtorch y su juego de tubos
- 1 soporte para la pluma
- 2 botellas de oxígeno
- 2 agujas 6/10mm
- 1 aguja 8/10mm
- 2 agujas 10/10mm
- 1 aguja 12/10mm

Kit de branchement Microtorch III

- 1 détenteur propane
- 1 détenteur oxygène
- 3 mètres de tuyau propane
- 3 mètres de tuyau oxygène
- 1 paire de tétines anti-retour
- 2 colliers de serrage

Ref. € HT
FU35/0375 420,24

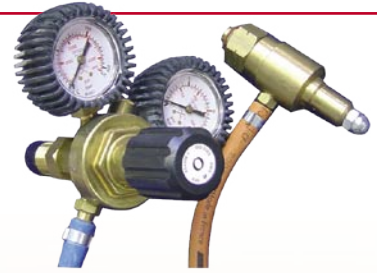

Gas connection set for Microtorch III:
-1 propane pressure reducing valve
-1 oxygen pressure reducing valve
-3 meters of gas tube
-3 meters of oxygen tube
-1 couple of reverse lock parts
-2 clamping collars

Komplettes Set zum Anschluss Ihres Microtorch III:
-1 Propan-Druckreduzierventil
-1 Sauerstoff-Druckreduzierventil
-3 Meter Schlauch für Propangas
-3 Meter Schlauch für Sauerstoff
-1 Paar Klappenventile Anti-Rücklauf
-2 Klemmringe

El kit completo par la conexión con Microtorch III:
-1 descompresor para el gas propano
-1 descompresor para el oxígeno
-3 metros de tubo para el gas propano
-3 metros de tubo para el oxígeno
-1 par de válvulas anti retorno
-2 abrazaderas

Adaptateur Oxygaz 2750°C

- 1 tête de chalumeau
- 1 robinet oxygène avec tuyau
- 1 aiguille 10/10mm
- 1 aiguille 12/12mm
(6/10 et 8/10mm en option)

Ref. € HT
FU36/0313 84,05



Adapter Oxygaz 2750°C
-1 torch head
-1 oxygen nozzle and connecting hose
-1 needle 10/10mm
-1 needle 12/12mm
(6/10 and 8/10mm separately)

Adapter Oxygaz 2750°C
-1 Schweißkopf
-1 Sauerstoff-Hahn und Verbindungs-Schlauch
-1 Lötdüse 10/10mm
-1 Lötdüse 12/12mm
(6/10 and 8/10mm separat erhältlich)

Adaptador Oxygaz 2750°C
-1 cabeza de mechero
-1 llave de paso del oxígeno con su tubo de conexión
-1 aguja 10/10mm
-1 aguja 12/10mm
(6/10 y 8/10 separado)

Adaptateur TriOxy 2750°C

- 1 tête de chalumeau
- 1 robinet 3 oxygène avec tuyau
- 1 aiguille 10/10mm
- 1 aiguille 12/12mm
(6/10 et 8/10mm en option)

Ref. € HT
FU36/0395 153,94

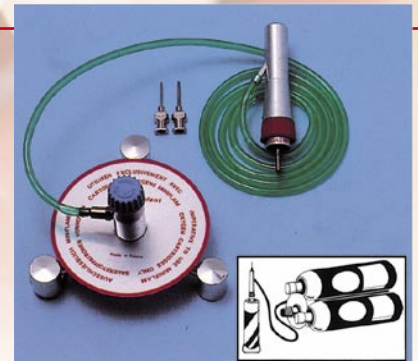

Adapter TriOxy 2750°C
-1 torch head
-1 nozzle 3 oxygen and connecting hose
-1 needle 10/10mm
-1 needle 12/12mm
(6/10 and 8/10mm separately)

Adapter TriOxy 2750°C
-1 Schweißkopf
-1 Verteilerplatte mit 1Hahn für 3 Sauerstoffflaschen und Verbindungs-Schlauch
-1 Lötdüse 10/10mm
-1 Lötdüse 12/12mm
(6/10 and 8/10mm separat erhältlich)

Adaptador TriOxy 2750°C
-1 cabeza de mechero
-1 llave de paso 3 oxígeno con su tubo de conexión
-1 aguja 10/10mm
-1 aguja 12/10mm
(6/10 y 8/10 opcional)

Fers à souder pour l'étain. Ils s'adaptent d'un geste sur les têtes de chalumeaux A et B, AP et BP. La montée en température est très rapide (20 s) et maintenue avec un débit minimum.

Ref. € HT
A, B FU36/0452 4,14
AP, BP FU36/0458 8,28



The soldering irons for tin soldering are adaptable on one motion to the A and B, AP and BP torch heads. The increase in temperature is fast (20 s) and can be maintained with a minimum flow of gas.

LötKolben für das Schweißen von Zinn. Einfach anzupassen auf A oder B, AP oder BP Schweißköpfe. Die Temperatur steigt extrem schnell (20 s) und bleibt konstant bei einer Einstellung mit minimalem Gas-Ausstoß

Soldadores de estaño. Sencillamente se adapta a las cabezas de mechero A y B, AP y BP. Alcanza rápidamente (20s) la temperatura necesaria se mantiene con un coste mínimo.

Accessoires

Accessories - Verschiedenes Zubehör - Accesorios

FLAMME



46/1502



46/1503



46/1504



46/1511

Brasure argent / Silver solder
Silber Hartlot / Soldadura de plata cubierta

Ref.	€ HT	
FU46/1502	32,04	40%, flux C22
FU46/1503	20,39	Flux extérieur, 5 baguettes sous blister / 5 sticks 5 Stäbe, Flux überzogen / Con desoxidante, 5 varillas
FU46/1504	23,18	35%, Flux incorporé / 35%, flux incorporated mit integriertem Flux / con desoxidante incorporado
FU46/1511	23,18	Brasure acier / Steel solder Stahl Hartlot / Soldadura de acero

Jusqu'à épuisement des stocks
Until the end of stocks / So langer der Vorrat
reicht / Hasta el final del existencia

Basse fusion, flux D.A.N. en pot
Low melting point
Niedriger Schweißpunkt, Flux D.A.N.
Baja fusion con desoxidante D.A.N.

La pâte Isoflam isole la proximité des soudures jusqu'à 3000°C sans laisser de trace, évite le démontage fastidieux des pièces sensibles à l'échauffement, protège chromage, zingages, caoutchouc, plastiques, câbles électriques, peinture, verre, textiles...



Ref. € HT
FU46/15201 15,97

The Isoflam paste protects and isolates the area next to the solder, without staining and avoids the tedious dismantling of parts sensitive to overheating; protects chrom, zinc, rubber, plastics, electric cables, paint, glass, textiles...

Die Isoflam Paste ist hitzeisolierend und schützt in der Nähe von Schweißstellen bis zu 3000°C, ohne jegliche Spur zu hinterlassen. Somit kann man kompliziertes Abmontieren von hitzeempfindlichen Teilen vermeiden. Sie isoliert verchromte und verzinkte Teile, Gummi, Plastik, elektrische Kabel, Farbe, Glass, Textil...

La pasta Isoflam protege y aísla la zona alrededor de las soldaduras hasta 3000°C, sin dejar rastros. Evita el desmontaje fastidioso de las piezas sensibles al calentamiento. Protege los cromados, los galvanizaciones con zinc, el caucho, los plasticos, los cables electricos, la pintura, el vidrio, los tejidos...

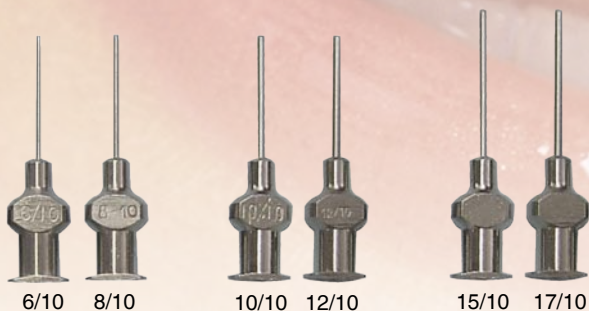

Aiguille / Needle
Lötdüse / Aguja

Ref.	€ HT	
FU36/0411	3,93	6/10
FU36/0412	3,93	8/10
FU36/0413	3,93	10/10
FU36/0414	3,93	12/10
FU36/0415	3,93	15/10
FU36/0416	3,93	17/10

Jeux d'aiguilles pour chalumeaux (2)
Solder needles sets (2)
Lötdüsen Set (2)
Juegos de agujas (2)

Ref.	€ HT	
FU36/0406	10,18	10/10 - 12/10 (Blister)
FU36/0453	10,18	6/10 - 8/10 (Blister)

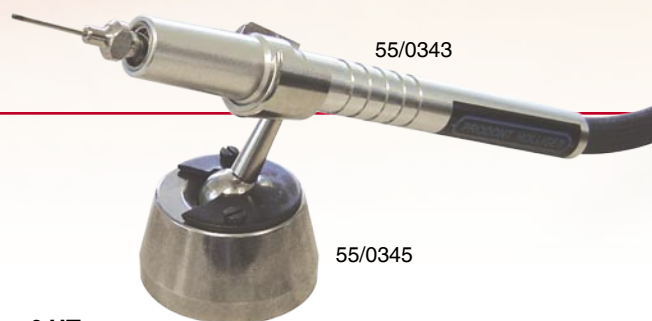

55/0343

55/0345

Injecteurs / Injectors
Injektor / Inyector

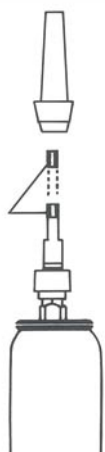

Ref.	€ HT	
FU36/0455	8,59	A, AP
FU36/0456	6,26	B, BP
FU36/0457	4,24	FL, GF, GFP
FU36/0459	7,85	FFP
FU36/0460	8,06	GFP
FU37/0503	14,42	Laboflam ●
FU37/0506	14,85	Laboflam ●
FU37/0507	20,29	Holy ●
FU37/0508	20,90	Holy ●
FU38/0602	2,97	Maticflam
FU68/2025	5,09	Styloflam

Ref.	€ HT	
FU51/0393	16,13	Valve Miniflam S
FU55/0329	110,47	Distributeur Microtorch II Distributor / Verteilerplatte / Distribuidor
FU55/0335	65,67	Distributeur Microtorch I
FU55/0343	48,91	Stylo Microtorch II Pen / Brennerhandstück / Pluma
FU55/0345	25,78	Support stylo Microtorch II / Pen stand Halte für Brennerhandstück / Soporte para pluma
FU55/3210	16,13	Jeu tuyaux fibre de verre Microtorch II Tubes / Schlauch-Set / Tubos
FU35/0464	8,17	Jeu de joints Microtorch I / gaskets
FU35/0465	5,30	Jeu de joints Microtorch II / gaskets

Gaz & Oxygène

Oxygen & gas
Sauerstoff und Gas
Oxígeno y gas

Ref.	€ HT	
FU47/1601	123,29	Microtorch) 12 pcs
FU47/1602	132,87	Protorch, Maticflam, Styloflam) 12 pcs
FU47/1621	61,39	Microtorch, Miniflam) 6 pcs



47/1601
 Oxygène 1L.
 Oxygen
 Sauerstoff
 Oxígeno



47/1602
 Gaz 400ml.
 Gas



47/1621
 GP VAPOR Gaz 70ml.
 Gas

FLAMME

Adaptateurs pour tuyaux de gaz souples Holy, Thermocouple, Laboflam *Adapter / Adaptador*

Ref.	€ HT
FU37/1300	14,11
FU37/1301	14,11



37/1300
 Butane, propane 14mm.

37/1301
 Gaz naturel 22mm.
 Natural gas / Erdgas

Containers Rechargeables S

Ref.	€ HT
FU51/0345	61,08
FU51/0346	61,32



51/0345
 Diam. 38mm.
 Vol. 60ml



51/0346
 Diam. 25mm.
 Vol. 60ml

Pince Crocodile

Revolving clip / orientierbare Zange / Pinza orientable

Ref.	€ HT
FU36/0450	0,95
FU36/0451	23,38

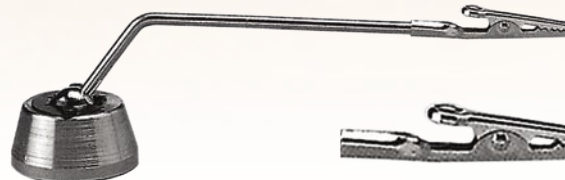

36/0451



36/0450
 Clip

Coupelle à cire

Wax cup / Wachsschale / Copela para cera
Laboflam & Maticflam

Ref.	€ HT
FU37/0580	24,40



Jusqu'à épuisement des stocks
Until the end of stocks / So langer der Vorrat reicht / Hasta el final del existencia

MODELES

Modelos

Models / Modell / Modelos

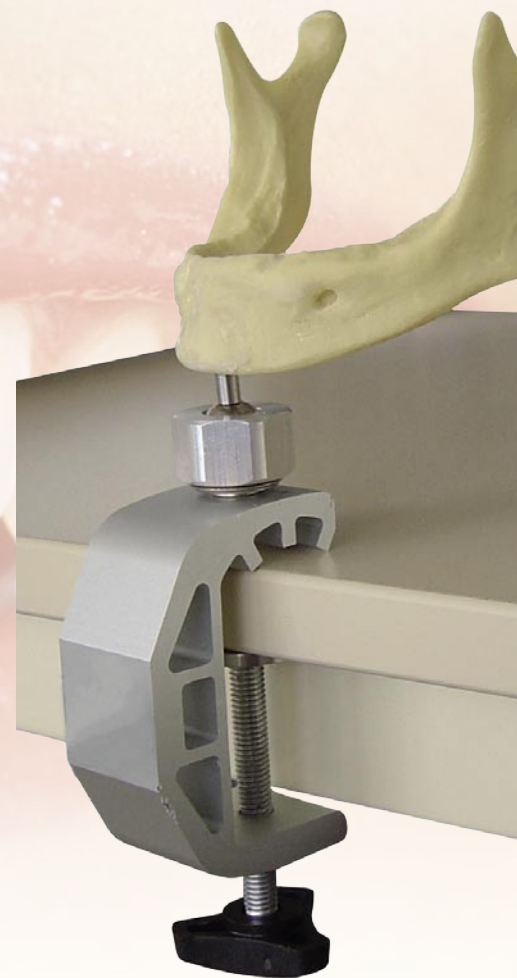
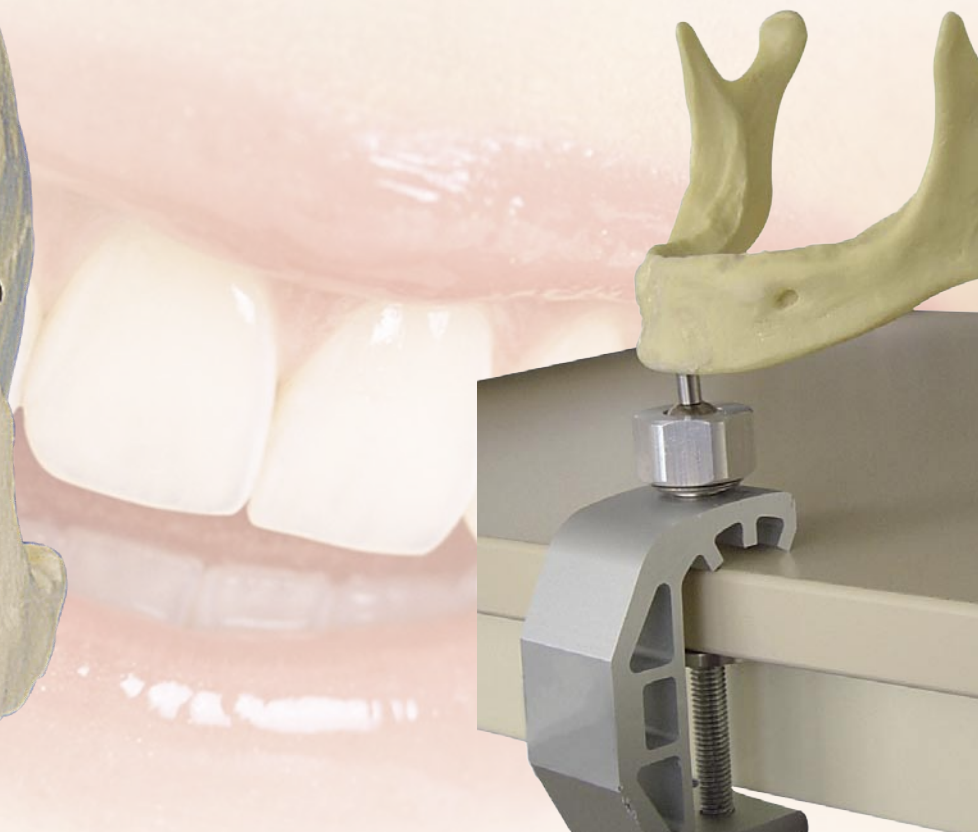

Cubes Cristal Design en 3D

3D Design Crystal Cubes



Modèle sinus avec implants
sinus model / Sinusmodell / Modelo de seno



Mandibule avec implants
mandible / Unterkieferformen / Mandibulas



Crâne
skull / Schädelmodell / Craneo

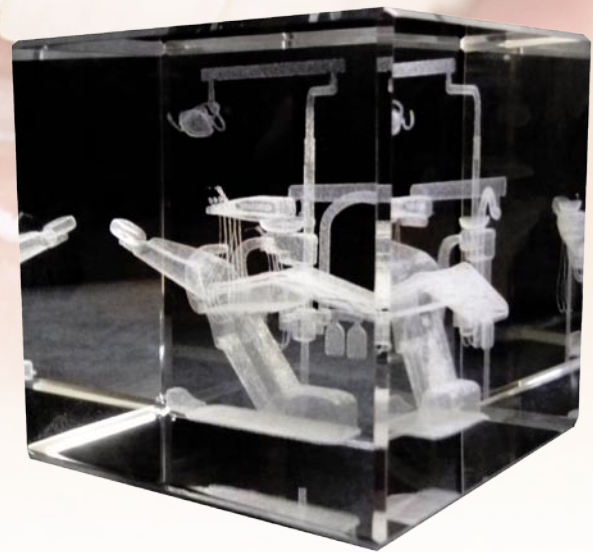

Fauteuil
Chair / Behandlungseinheit / Unidad dental



**Cubes transparents
 avec incrustation de motifs
 en 3 dimensions.**

Existent en 2 tailles (2 sizes):
 60x60mm (FT01)
 100x100mm (FT02)

Ref.	€ HT
FT01	92,00
FT02	319,00

Modèle transparent supérieur avec implants et facettes

Upper transparent model with implant, laminate
 Oberkiefer, transparent mit Implantat und Facette
 Modelos transparentes superiores, con implantes y facetas

MODELES

PFM3

Centrale céramo-métallique
 Metal bonded porcelain central
 Metallkeramikkrone Schneidezahn
 Central de metal-porcelana

Jacket
 Jacket crown
 Jacketkrone
 Funda

Facette
 Laminate
 Keramik-Facette
 Faceta de porcelana

Jacket sur faux moignon métallique
 Thimble post jacket crown
 Jacketkrone auf Metallstumpf
 Funda sobre falso muñón metálico

Bridge céramo-métallique
 Metal bridge with facings
 Dreigliedrige Brücke
 Puente de 3 piezas

Bridge MARYLAND
 Bridge
 Klebebrücke
 Puente colado

Couronne céramique sur implant
 Porcelain crown with implant
 Implantatkrone
 Corona sobre implante

Couronne coulée dorée
 Full metal crown
 Metallkrone
 Corona metálica

Onlay

Inlay céramique
 Porcelain inlay
 Keramik Inlay
 Inlay de porcelana



40/08148

Ref. 40/08138
 Doré / Golden / Vergoldet / Dorado
 Rhodié / Rhodium plated / Vernickelt / Niquelado 40/08148



Le modèle €HT
 741,57

Centrale céramo-métallique
 Metal bonded porcelain central
 Metallkeramikkrone Schneidezahn
 Central de metal-porcelana

Jacket
 Jacket crown
 Jacketkrone
 Funda

Facette
 Laminate
 Keramik-Facette
 Faceta de porcelana

Jacket sur faux moignon métallique
 Thimble post jacket crown
 Jacketkrone auf Metallstumpf
 Funda sobre falso muñón metálico

Bridge céramo-métallique
 Metal bridge with facings
 Dreigliedrige Brücke
 Puente de 3 piezas

Bridge céramique
 Porcelain bridge with facings
 Dreigliedrige Brücke
 Puente de 3 piezas

Couronne céramique sur implant
 Porcelain crown with implant
 Implantatkrone
 Corona sobre implante

Couronne coulée metal
 Full metal crown
 Metallkrone
 Corona metalica

Onlay céramique
 Porcelain onlay
 Keramik Onlay
 Onlay de porcelana

Inlay céramique
 Porcelain inlay
 Keramik Inlay
 Inlay de porcelana

Ref.
 40/08168

Modèle transparent supérieur avec implants et facettes, onlay céramique

Upper transparent model with implant, laminate, porcelain onlay
 Oberkiefer, transparent mit Implantat und Facette, Keramik Onlay
 Modelos transparentes superiores, con implantes y facetas, onlay de porcelana



Le €HT
 modèle 741,57

Modèle transparent supérieur céramique avec implants, facettes, bridge

Upper transparent model, porcelain, with implant, laminate, bridges
 Oberkiefer, transparent mit Keramik-Implantaten, Facette, Keramik-Brücken
 Modelos transparentes superiores de porcelana con implantes, facetas y puentes

MODELES

PFCE

Bridge céramique sur 2 implants
 Porcelain bridge on 2 implants
 Dreigliedrige Keramik-Brücke auf 2 Implantaten
 Puente de 3 piezas, porcelana sobre 2 implantes

Bridge céramique sur 2 moignons naturels
 Porcelain bridge on 2 stumps
 Dreigliedrige Keramik-Brücke auf natürlichen Stumpfen
 Puente de 3 piezas, porcelana sobre pilares naturales

Onlay céramique
 Porcelain onlay
 Keramik onlay
 Onlay de porcelana

Jacket céramique
 Jacket
 Keramik-Jacketkrone
 Funda de porcelana

Facette céramique
 Laminate
 Keramik-Facette
 Faceta de porcelana

Inlay céramique
 Porcelain inlay
 Keramik-Inlay
 Inlay de porcelana

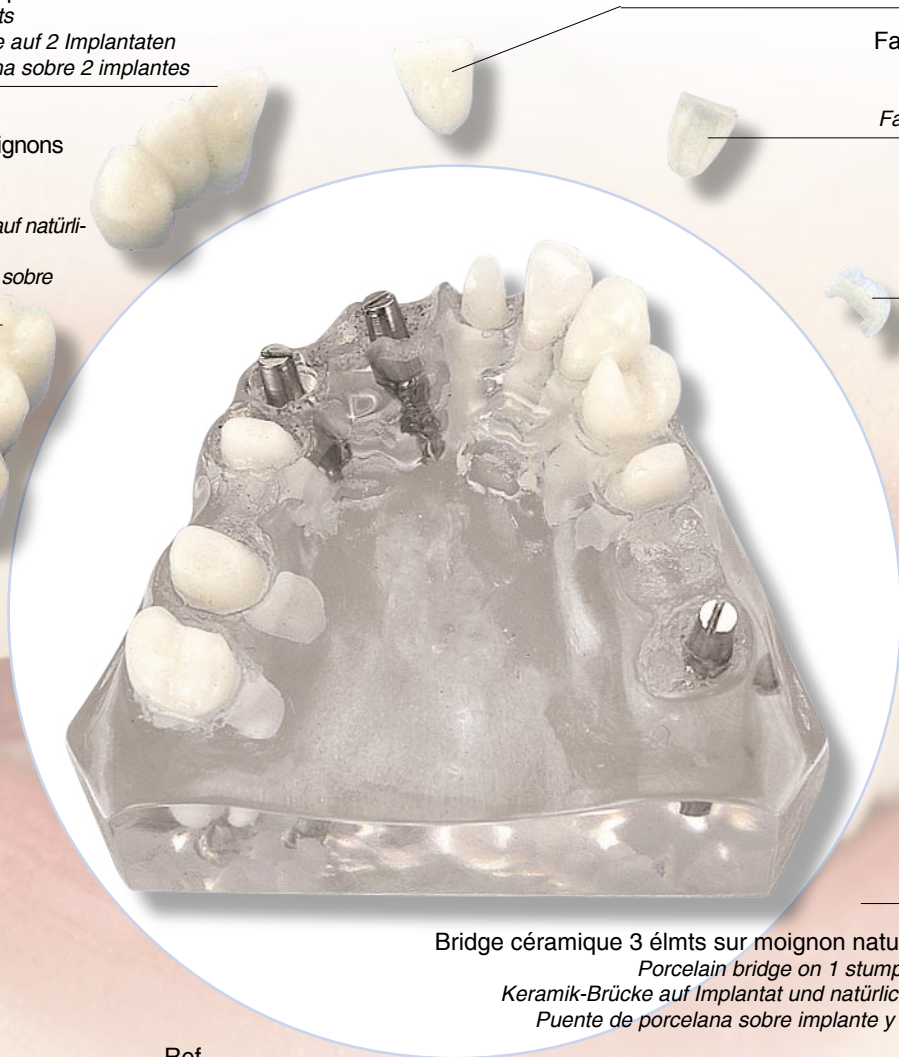

Bridge céramique 3 élmts sur moignon naturel et implant
 Porcelain bridge on 1 stump and 1 implant
 Keramik-Brücke auf Implantat und natürlichem Stumpfen
 Puente de porcelana sobre implante y muñón natural

Ref.
 40/08158



Le modèle €HT
 549,55

Bridge antérieur 3 élmts, 2 implants
 Anterior bridge 3elmts, 2 implants
 Dreigliedrige Keramik-Brücke auf 2 Implantaten
 Puente de 3 piezas, porcelana sobre 2 implantes

Bridge Maryland
 Bridge
 Keramische Klebebrücke
 Puente de porcelana colado

Bridge avec inlay sur I4
 Bridge with inlay on tooth UR4
 Keramik-Brücke mit Inlay
 Puente de porcelana con inlay

Couronne céramique
 Porcelain crown
 Keramikkrone
 Corona de porcelana

Couronne céramique
 Porcelain crown
 Keramikkrone
 Corona de porcelana



Bridge céramique 3 élmts sur moignon naturel et implant
 Porcelain bridge on 1 stump and 1 implant
 Keramik-Brücke auf Implantat und natürlichem Stumpf
 Puente de porcelana sobre implante y muñón natural

Ref.
 40/08150



Le €HT
 modèle 555,91

Bridge céramo-métallique
 Metal bonded porcelain bridge
 Dreigliedrige Brücke auf natürlichen Stumpfen
 Puente, sobre pilares naturales

MARYLAND
 Bridge
 Klebebrücke
 Puente

Couronne céramo-métallique, glissière distale
 Metal crown porcelain facing, precision attachment fitting
 Metallkeramikkrone mit Geschiebe, distal
 Corona metal-porcelana, guía distal



40/08501 Modèle avec couronne dorée
 Model with gold plated crown
 Vergoldete Vollgusskrone
 Corona dorada

40/08502 Modèle avec couronne rhodiée
 Model with rhodium plated crown
 Vernickelte Vollgusskrone
 Corona niquelada

Plaque partielle haut 5 dents avec taquets occlusaux et glissière
 Partial chrome denture 5 teeth with clasps and occlusal rests
 5 Zähne, mit Gussklammern und Geschiebe
 Placa superior parcial, metálica, 5 dientes, tacas oclusales y guía



Doré / Golden / Vergoldet / Dorado	Ref. 40/08501
Rhodié / Rhodium / Vernickelt / Niquelado	40/08502



Ce modèle démontre la possibilité d'un travail combiné entre une plaque métallique avec couronne glissière et une couronne fraisée, qui assure une très bonne tenue en bouche ainsi qu'un très bon ajustement.

Le modèle €HT
 694,89



This model demonstrates the success of a combined work between a partial denture with metal crown and a full metal crown, which ensures an excellent fitting.



Dieses Modell zeigt die Möglichkeit einer Kombination von Prothese und Teleskopkrone, wodurch sicherer Halt und angenehmer Tragekomfort erzielt werden.



Este modelo demuestra la posibilidad de un trabajo que combine la placa metálica con corona deslizante y la corona fresada garantizando un excelente sujeción en la boca y un perfecto ajuste.

Modèle supérieur, 14 prothèses
Upper model, 14 prosthesis - Kunststoffmodell, Ober, 14 Zahnersatzformen

C.I.V. centrale
Full gold crown and facing
Verblendkrone Schneidezahn
C.I.V. central

Couronne jacket céramique
Porcelain jacket crown
Keramikkrone
Corona de porcelana

RICHMOND latérale
Post jacket crown with facing
Metallkeramik-Stiftkrone Frontzahn
RICHMOND lateral de metal porcelana

Jacket sur faux moignon
métallique
Thimble post jacket crown
Jacketkrone auf Metallstumpf
Funda sobre falso muñón
metalico

Bridge céramo-métal-
lique 3 éléments
Metal bonded porcelain
bridge
Dreigliedrige Brücke auf
natürlichen Stumpfen
Puente 3 piezas, sobre
pilares naturales

MARYLAND
Bridge
Klebebrücke
Puente

Inlay M.O.D.
Metal inlay
Metall inlay
Inlay metalico

Couronne coulée métal
Full metal crown
Vollgusskrone
Corona de metal colado

Le €HT
modèle 1050,29

Ref.
40/0953
40/0954

Doré / Golden / Vergoldet / Dorado
Rhodié / Rhodium / Vernickelt / Niquelado

Ce modèle supérieur, en résine, avec dents et moignons amovibles sur pivots comporte 14 prothèses différentes, toutes adaptables au modèle maître. Ce support de communication permet de présenter visuellement aux patients les divers types de prothèses conjointes disponibles. La compréhension et le choix du traitement sont ainsi plus rapides.



The resin upper model with teeth contains 14 different prosthesis, all compliant with the master model. This communication device allows a better understanding of the required treatment between the patient and the dentist. This complete demonstration set comes in a plexiglass case and will become an essential tool.



Kunststoffmodell des Oberkiefers mit abnehmbaren, auf Pins befestigten Zähnen und Zahnstumpfen. Set mit 14 verschiedenen Zahnersatzformen, jeweils kompatibel mit dem Trägermodell.



Modelo superior en resina con dientes y muñones intercambiables sobre pivotes. Conjunto con 14 prótesis distintas, todas adaptables al modelo maestro.



Bridge C.I.V. 3 éléments
Bridge and facings
Dreigliedrige Brücke, vestibular verblendet
Puente de 3 piezas

Facette céramique
Laminate
Keramik Facette
Faceta de porcelana

Centrale céramo-métallique
Metal bonded porcelain central
Metallkeramikkrone Frontzahn
Central de porcelana-metalico

Inlay céramique
Porcelain inlay
Keramik Inlay
Inlay de porcelana

Onlay céramique
Porcelain onlay
Keramik Onlay
Onlay de porcelana

Onlay métal
Metal onlay
Metall Onlay
Onlay metálico

MODELES
Modèle supérieur, 14 prothèses
Upper model, 14 prosthesis - Kunststoffmodell, Ober, 14 Zahnersatzformen

Ces modèles pédagogiques par excellence reproduisent fidèlement la dentition d'un enfant de 4 ou 9 ans, sur une base de résine transparente permettant la visualisation des dents de sagesse en préparation.

MODELES

Modèles Enfants
Children models - Kindermodelle - modelos para niños



41/0904

9 ans / 9 years old / 9 Jahre / 9 años



These teaching models faithfully imitate the full dentition of a 4 or 9 years old child clearly visible through the simulated gum work and shows the wisdoms in formation.



Die in pädagogischer Hinsicht überaus empfehlenswerten Modelle A4 und A9 spiegeln exakt die Bezahnung eines 4 - 9 jährigen Kindes wider. Dank des transparenten Kunststoffmaterials sind die im Zahnfleisch noch verborgenen Weisheitszähne sichtbar.



Los modelos A4 y A9 , pedagógicos por excelencia, reproducen fielmente la dentición de un niño de 4 o 9 años sobre una base de resina transparente que permite la visualización de las muelas del juicio en formación.



41/0907

4 ans / 4 years old / 4 Jahre / 4 años

Avec Charnière métal / metal hinge

Ref. €HT

41/0904 **461,49**

Avec Charnière plastique / Plastic hinge

Ref. €HT

41/09042 **397,84**

Avec Charnière métal / metal hinge

Ref. €HT

41/0907 **472,10**

Avec Charnière plastique / Plastic hinge

Ref. €HT

41/09072 **423,30**

Le modèle Typodont montre le résultat d'un traitement orthodontique.

 *The Typodont model shows the result of an orthodontic treatment.*

 *Das Modell Typodont zeigt das Ergebnis nach der kieferorthopädischen Behandlung.*

 *El modelo Typodont es el resultado de la ortodoncia.*



Ref. €HT
42/1715R 110,33



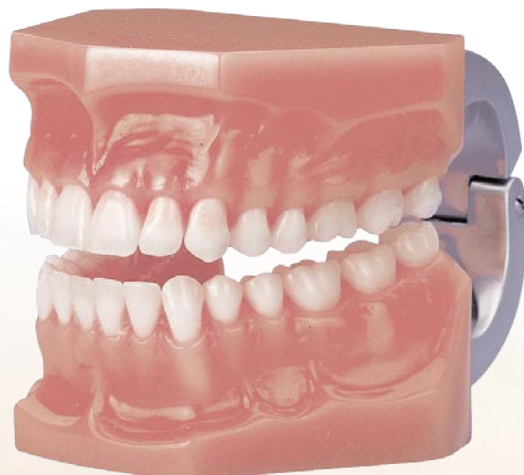

Modèles transparents, semi-rigides, dents amovibles

Transparent models, flexible, removable teeth

Transparent, halbweiches Zahnfleisch, herausnehmbaren Zähnen

Transparentes, semirigidos, dientes intercambiables

Ref. €HT
41/09210 145,34

Haut, 16 dents
Upper, 16 teeth
OK, 16 Zähnen
Superior, 16 dientes

Ref. €HT
41/09211 145,34

Bas, 16 dents
Lower, 16 teeth
UK, 16 Zähnen
Inferior, 16 dientes

Ref. €HT
41/0922 302,36

Haut et bas, 32 dents
Upper & lower, 32 teeth
OK & UK, 32 Zähnen
Superior & inferior, 32 dientes

Ref. €HT
41/0931 419,06

Haut et bas, 32 dents, charnière métal
Upper & lower, 32 teeth, metal hinge
OK & UK, 32 Zähnen, Metallscharnier
Superior & inferior, 32 dientes, bisagra metálica

Ref. €HT
41/09322 355,40

Haut & bas, 32 dents, charnière plastique
Upper & lower, 32 teeth, plastic hinge
OK & UK, 32 Zähnen, Plastikscharnier
Superior & inferior, 32 dientes, bisagra plástica

Modèles roses, semi-rigides, dents amovibles

Pink models, flexible, removable teeth

Fleischfarben, halbweiches Zahnfleisch, herausnehmbaren Zähnen

Rosados, semirigidos, dientes intercambiables

Ref. €HT
41/09260 145,34

Ref. €HT
41/09261 145,34

Ref. €HT
41/0927 302,36

Ref. €HT
41/0936 419,06

Ref. €HT
41/09372 371,32

Modèles transparents, rigides, dents non-amovibles

Transparent models, hard, non-removable teeth

Transparent, festes Zahnfleisch, festsitzende Zähnen

Transparentes, rigidos, dientes fijos

Ref. €HT
41/09010 149,59

Haut, 16 dents
Upper, 16 teeth
OK, 16 Zähne
Superior, 16 dientes

Ref. €HT
41/09011 149,59

Bas, 16 dents
Lower, 16 teeth
UK, 16 Zähne
Inferior, 16 dientes

Ref. €HT
41/0902 307,66

Haut et bas, 32 dents
Upper & lower, 32 teeth
OK & UK, 32 Zähne
Superior & inferior, 32 dientes

Ref. €HT
41/0906 445,58

Haut et bas, 32 dents, charnière métal
Upper & lower, 32 teeth, metal hinge
OK & UK, 32 Zähne, Metallscharnier
Superior & inferior, 32 dientes, bisagra metálica

Ref. €HT
41/09062 371,32

Haut & bas, 32 dents, charnière plastique
Upper & lower, 32 teeth, plastic hinge
OK & UK, 32 Zähne, Plastikscharnier
Superior & inferior, 32 dientes, bisagra plástica

Modèles roses, rigides, dents non-amovibles

Pink models, hard, non-removable teeth

Fleischfarben, festes Zahnfleisch, festsitzende Zähnen

Rosados, rigidos, dientes fijos

Ref. €HT
41/09110 143,22

Ref. €HT
41/09111 143,22

Ref. €HT
41/0912 317,21

Ref. €HT
41/0916 477,41

Ref. €HT
41/09162 371,32



pour Modèle Paro - for Paro Model - für Modell paro - para Modelo paro	Ref.	€HT
Set 27 dents / 27 teeth set / 27 Zähne/ 27 dientes	42/1500	105,03
Unité / Unit / Einzeln / Unidades	42/1511...47	5,15
pour Modèles souples - for flexible Model	Ref.	€HT
für halbfestem Modell - para Modelo flexibles	42/1015	122,00
Set 32 dents / 32 teeth set / 32 Zähne/ 32 dientes	42/1111...47	5,15
Unité / Unit / Einzeln / Unidades		

Simulateurs Endo

Transparent root canal cubes - Endo Simulatoren - Simuladores endo

Recommandés pour l'initiation à la dévitalisation des dents. Ces simulateurs transparents comportent 4 canaux radiculaires courbes ou droits, permettant d'évaluer l'intervention.

Le Simulateur **€HT 20,16**

Droit / Straight / Gerade / Rectos Ref. 42/1902
Courbe / Curved / Gebogen / Curvos Ref. 42/1903

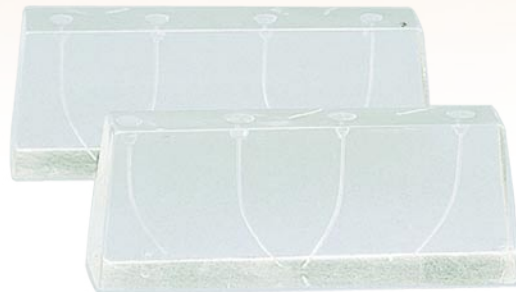
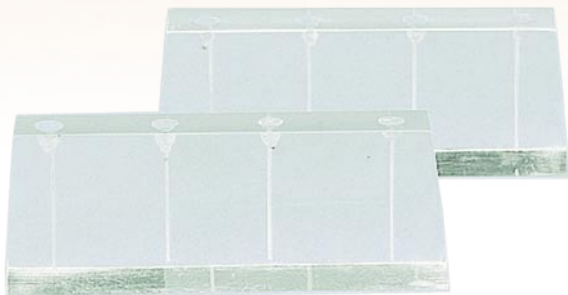

Recommended to study the devitalization of teeth. These transparent root canal cubes with 4 canal, either straight or curved, allow to state the effected root canal treatment.



Empfehlenswert für das Erlernen der Devitalisierung von Zähnen. Diese Simulatoren verfügen über vier gebogene oder gerade Wurzelkanäle und aufgrund ihrer transparenten Farbe sind einzelne Arbeitsschritte sehr gut sichtbar.-



Recomendados para iniciarse en desvitalización de dientes. Estos simuladores transparentes incluyen 4 canales radiculares curvos o rectos, permitiendó verificar el trabajo realizado.

Modèles édentés partiels

Partially edentulous states - Teilweiser Zahnverlust - Caída parcial de dientes

Les 6 modèles d'édentition partielle haut et bas sont disponibles à l'unité. Toutes les dents en place sont amovibles sur pivots.



41/0951
Haut, 6 dents / Upper, 6 teeth
Oberkiefer, 6 Zähne/ Superior, 6 dientes



41/0952
Haut, 8 dents / Upper, 8 teeth
Oberkiefer, 8 Zähne/ Superior, 8 dientes



41/0953
Haut, 9 dents / Upper, 9 teeth
Oberkiefer, 9 Zähne/ Superior, 9 dientes



41/0965
Bas, 2 dents / Lower, 2 teeth
Unterkiefer, 2 Zähne/ Inferior, 2 dientes



41/0966
Bas, 6 dents / Lower, 6 teeth
Unterkiefer, 6 Zähne/ Inferior, 6 dientes



41/0967
Bas, 8 dents / Lower, 8 teeth
Unterkiefer, 8 Zähne/ Inferior, 8 dientes



The 6 upper and lower models showing partially edentulous states are sold individually. The teeth are all removable on pins. these models can be used with the Model Kit 2.



Die 6 Modelltypen von teilweisem Zahnverlust im Ober- und Unterkiefer sind einzeln erhältlich. Alle Zähne sind herausnehmbar. Diese Modelle können mit dem Modell Kit 2 kombiniert werden.



Los 6 modelos tipos de pérdida parcial de dientes superior e inferior están disponibles por unidad. Todos los dientes son intercambiables sobre pivote. estos modelos pueden ser utilizados sobre el Modelo Kit 2.

Ref.	€ HT
41/0951	148,53
41/0952	158,07
41/0953	164,44
41/0965	116,70
41/0966	136,86
41/0967	147,47



41/0975

Crâne réalisé en résine façon os. Excellente reproduction de l'anatomie humaine. Avec maxillaire et mandibule, 28 dents en occlusion. Echelle 1.

Ref. €HT
41/0975 615,32

41/0972
Edenté (Prix sur demande)
Edentulous (price on request)
ohne Zähne (Preis auf An-
frage)
Caída de dientes



Adult Skull model, bone imitation resin. Excellent copy of the human anatomy. With maxillary and mandible, 28 removable teeth. Scale 1.



Schädelmodell eines erwachsenen Menschen, aus hartem Kunststoff. Hervorragende Nachbildung der menschlichen Anatomie. Mit Ober und Unterkiefer, 28 Zähne in Okklusion.



Cráneo adulto realizado en resina tipo oseo, excelente reproducción de la anatomía humana. Con maxilar y mandíbula, 28 dientes montados en occlusión

Modèle haut et bas avec chacun 6 dents et gencive amovibles laissant apparaître le maxillaire alvéolé et la mandibule sous-gingivale. Ce modèle pédagogique est destiné à la démonstration des dommages que peut causer la périodontie. Il présente sur sa moitié gauche une structure totalement saine, permettant la comparaison avec la moitié droite qui est atteinte et comporte:

Modèle du Haut

- la rétraction et l'inflammation gingivale
- les dépôts de tartre (sur demande)
- une résorption alvéolaire après la perte de la dent n°12 et 42
- une décalcification du siège alvéolaire des dents en place
- une mobilité des dents fragilisées par l'atteinte des ligaments
- l'extrusion apparente de la dent n°16

Modèle du Bas

- abcès et fistule de la gencive sur le n°44
- périodontite hypertrophique sur le n°47 et importante carie de la face occlusale
- carie du collet sur le n°43
- carie de l'émail et carie du collet sur le n°44
- carie distale sur le n°45
- carie de l'émail sur le n°46

 Upper and lower model with 6 removable teeth and gum showing the under gingivae maxillary rougae. This teaching model shows the consequences of the periodontal disease. The left quadrant is in a healthy normal state whereas the right quadrant is afflicted with the disease and displays:

Upper model

- the gum retraction and inflammation
- the tartar deposit (on request)
- the tooth socket resorption due to the loss of tooth UR2 and LR2
- the socket neck decalcification of the 6 standing teeth
- the mobility of the fragilized teeth caused by the slow impairment of the ligaments.
- the visible extrusion of tooth UR6

Lower model

- abscess and fistula of the gum tissue on tooth LR4
- hypertrophied periodontitis on tooth LR7 and tooth decay on the occlusal side.
- tooth decay on the neck of tooth LR3
- tooth decay on the enamel and neck of tooth LR4
- distal tooth decay on tooth LR5
- tooth decay on the enamel of tooth LR6

 Gebissmodell, OK und UK mit jeweils 13 Zähnen. Zahnfleisch und 6 Zähne abnehmbar. Ermöglicht die Sichtbarmachung der einzelnen Alveolen sowohl im Ober- als auch im Unterkiefer. Dieses Modell dient zur Darstellung der Schäden, die durch Zahnfleischerkrankungen verursacht werden können. Der Unterschied zwischen krankem und gesundem Zahnfleisch wird dadurch veranschaulicht, das die linke Hälfte im Gegensatz zur angegriffenen rechten Hälfte eine vollkommen gesunde Struktur aufweist:

Oben

- Zahnfleischrückbildung- und Entzündung
- Zahnsteinablagerungen (auf Anfrage des Kunden)
- Knochenabbau in den Alveolen nach Verlust der Zähne 12, 42
- Entkalkung des Zahnschmelzes der vorhandenen Zähne.
- Zahnverlagerung nach Schädigung des Ligaments
- Extrusion des Zahns 16

Unten

- Zahnfistel und Abszess auf 44
- Hypertrophie der Wurzelhaut auf 47, fortgeschrittene Karies auf der Kaufläche
- Zahnhalsskaries auf 43
- Zahnschmelz und Zahnhalsskaries auf 44
- Karies distal auf 45
- Zahnschmelzkaries auf 46

 Modelo superior e inferior con 6 dientes y encias intercambiables cada uno que dejan visualizar el maxilar alveolado y la mandíbula subgingival. Este modelo pedagógico esta destinado a la demostración de los estragos que puede causar la periodoncia. Sobre la mitad izquierda muestra una estructura totalmente sana que permite realizar la comparacion con la mitad derecha que esta afectada y que incluye:

Superior

- La retracción e inflamacion gingival
- Los depósitos de placa (a petición del cliente)
- Una resorcion alveolar tras la perdida de los dientes 12 y 42
- Una descalcificación del soporte alveolar de los dientes
- La movilidad de los dientes frágiles por el deterioro de los ligamentos
- La extrusión aparente del diente 16

Inferior

- Absceso y fistula de la encia en el 44
- Periodontitis hipertrófica en el 47 y caries importante de la cara oclusal
- Caries del cuello dental en el 43
- Caries del esmalte y caries del cuello dental en el 44
- Caries distal en el 45
- Caries del esmalte en el 46

Modèles Pério
Perio models - Modell Perio - Modelos perio

Ref. €HT **Haut et bas, tartre**
41/0938 631,24 *Upper and lower, tartar
Ober- und Unterkiefer, Zahnsteinablagerungen
Superior e inferior, placa*

Ref. €HT **Haut et bas**
41/0939 588,80 *Upper and lower
Ober- und Unterkiefer
Superior e inferior*

Ref. €HT **Haut et bas, charnière métal**
41/0940 646,09 *Upper and lower, metal hinge
Ober- und Unterkiefer, Metallscharnier
Superior e inferior, bisagra metálica*

Ref. €HT **Haut et bas, tartre, charnière métal**
41/0941 689,59 *Upper and lower, tartar, metal hinge
Ober- und Unterkiefer, Zahnsteinablagerungen, Metallscharnier
Superior e inferior, placa, bisagra metálica*

Ref. €HT **Haut et bas, charnière plastique**
41/09402 583,50 *Upper and lower, plastic hinge
Ober- und Unterkiefer, Plastikscharnier
Superior e inferior, bisagra plástica*

Ref. €HT **Haut et bas, tartre, charnière plastique**
41/09412 635,48 *Upper and lower, tartar, plastic hinge
Ober- und Unterkiefer, Zahnsteinablagerungen, Plastikscharnier
Superior e inferior, placa, bisagra plástica*

Ref. €HT **Haut**
41/0945 307,66 *Upper
Oberkiefer
Superior*

Ref. €HT **Haut, tartre**
41/0946 307,66 *Upper, tartar
Oberkiefer, Zahnsteinablagerungen
Superior, placa*

Ref. €HT **Bas**
41/0942 307,66 *Lower
Unterkiefer
Inferior*

Ref. €HT **Bas, tartre**
41/0943 307,66 *Lower, tartar
Oberkiefer, Zahnsteinablagerungen
Inferior, placa*

Ref. €HT **Gencive, Bas**
41/0944 47,74 *Lower gum
Unterkiefer Zahnfleisch
Encia inferior*

Ref. €HT **Gencive, Haut**
41/0947 46,68 *Upper um
Oberkiefer Zahnfleisch
Encia superior*

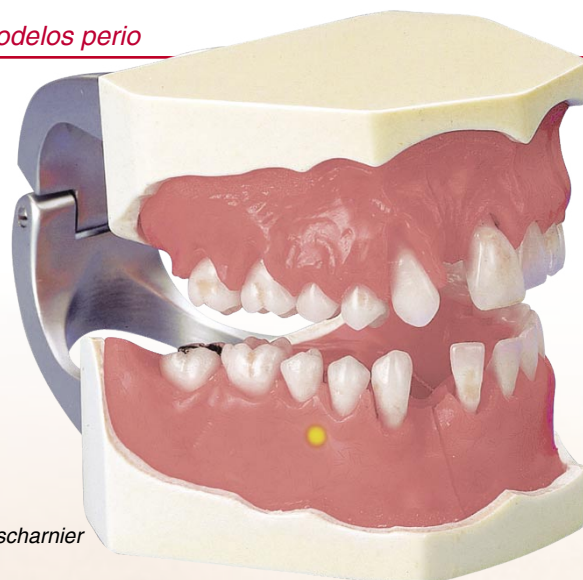

41/0940



41/0946



41/0945

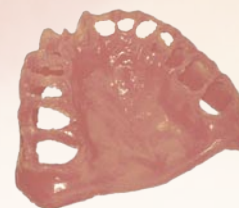

41/0947



41/0942



MODELES

Modèles Pério
Perio models - Modell Perio - Modelos perio



41/0901



Ecrou pour tête fantôme
 Phantom head thread
 Für Phantomköpfe
 Para cabezas de practica



Gencive amovible
 Replaceable gum
 Abnehmbares Zahnfleisch
 Encia y dientes intercambiables



41/09000
Avec tartre

Tartar
 Zahnsteinablagerungen
 Placa



Ces modèles bénéficient d'une approche morphologique la plus réaliste possible. Une attention toute particulière a été mise sur la représentation osseuse des problèmes gingivaux. Pour une plus grande durée de vie, la gencive et les dents sont remplaçables séparément.

La texture de la résine permet de simuler des préparations de cavités dentaires. Le relief osseux met en valeur plusieurs anomalies: alvéolyse, lésions intra-osseuse.

Modèle paro dents fixes, gencive amovible: La texture de cette gencive à usage unique est suffisamment résistante pour la mise en oeuvre de différents types de sutures.

Gencives haut et bas: souples et résistantes, elles permettent l'initiation à la suture et montrent plusieurs hypertrophies et récessions gingivales.

Dents anatomiques: toutes les dents peuvent être extraites de leur alvéole osseuse et remises en place sans difficulté.

All parts are designed faithfully to the gingival morphology with special care for the bone. In order to increase longevity, gum and teeth are replaceable separately.

The resin texture makes it possible to simulate required preparations for dental cavity work. The bone shape shows several anomalies: alveolar disease and intra-bone lesions.

Paro model with removable gum and fixed teeth: The texture of the single-use gum is ideal for studying suture points.

Upper and Lower gums: Soft and resistant, they show several gingival hypertrophies and recessions.

Anatomical teeth: all teeth are removable from their alveols.

Modell Paro Gebissmodell mit herausnehmbaren anatomischen Zähnen und Zahnfleisch. Die morphologische Beschaffenheit aller Elemente ist so naturgetreu wie möglich. Besonderes Augenmerk wurde dabei auf das Aussehen des Knochens bei Zahnfleischproblemen gelegt. Aufgrund der Möglichkeit, Zahnfleisch und Zähne getrennt zu ersetzen, ist dieses Modell überaus beständig und gut zu erhalten. Die Beschaffenheit des Kunststoffmaterials ermöglicht es, die Präparierung der Zahnhöhlen zu simulieren. Das Knochenrelief deutet auf einige Anomalien hin: Alveolyse, intraossäre Läsion.

Die Beschaffenheit und Widerstandsfähigkeit des Zahnfleisches ermöglichen das Ausführen von verschiedenen Nahttechniken.

Este modelo es una imitación morfológica de lo más realista. Se ha prestado una atención especial a la representación ósea de los problemas gingivales. Para dar una mayor vida útil al modelo, la encia y los dientes son reemplazables.

La textura de la resina permite simular la preparacion de cavidades dentales. El relieve óseo resalta varias anomalias: Alveolisis, lesion intraósea.

La textura de la encia, suficientemente resistente y flexible, permite realizar distintos tipos de sutura.

Modèles paro, gencives et dents amovibles

Paro models, removable gum & teeth
 Modell Paro, herausnehmbare Zähne & Zahnfleisch
 Modelo paro, encia y dientes removibles

Ref.	€HT	
41/09101	175,05	Haut / Upper / OK / Superior
41/09102	175,05	Bas / Lower / UK / Inferior
41/0901	357,52	Haut et bas / Upper & lower OK & UK / Superior & inferior

Dents

Teeth / Zähne / Dientes

42/1500	105,03	Set 27 dent
42/15..	5,15	Unité / Unit / Einzel / Unidad

Modèles paro, gencives amovibles, dents fixes

Paro models, removable gum, non-removable teeth
 Modell Paro, abnehmbares Zahnfleisch, festsitzende Zähne
 Modelo paro, encia reemplazable, dientes fijos

Ref.	€HT	
41/0910	84,87	Haut / Upper / OK / Superior
41/0911	84,87	Bas / Lower / UK / Inferior
41/09000	205,81	Haut et bas / Upper & lower OK & UK / Superior & inferior

Gencives

Gum / Zahnfleisch / Encia

41/0870	37,13	Haut / Upper / OK / Superior
41/0871	37,13	Bas / Lower / UK / Inferior

Modèles TP sur Fantôme pour Taille de Prothèse

Carving models - Übungsmodelle - Aprendizaje de Tallado

Modèles économiques jetables inférieur et supérieur permettant la taille des dents

Disposable carving models

Einweg-Trainingsmodell, Ober- und Unterkiefer, erlaubt die Bearbeitung der Zähne
modelos economicos desechables inferiores y superiores con posibilidad de corte de los dientes

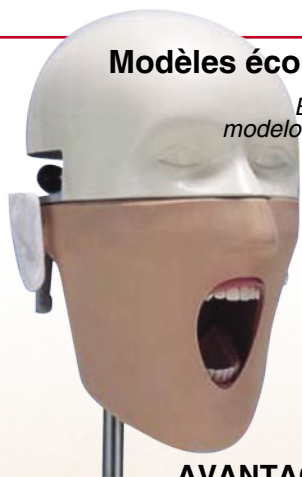

	Ref.	€HT
Haut / Upper / OK / Superior	42/1704	62,59
Bas / Lower / UK / Inferior	42/1705	62,59
Haut et bas / Upper & lower	42/1706	105,03
OK & UK / Superior & inferior		



AVANTAGES

- Ecrou de fixation sur fantôme
- Ne changez plus les dents
- Modèles réutilisables pour plusieurs TP
- Les dents fixes garantissent la fiabilité des évaluations lors des TP



ADVANTAGES:
suitable for phantom head
no need to replace the teeth
models reusable



VORTEILE:
Schraube zum Einpassen in Phantomköpfe
Das Ersetzen der Zähne ist überflüssig
Modell mehrmals verwendbar.
Die feststehenden Zähne garantieren die Zuverlässigkeit der
Bewertungen während des Trainings.



VENTAJAS:
Tuerca de fijación a la cabeza modelo
No hace falta cambiar los dientes
Reutilizable para varios trabajos
Los dientes fijos garantizan la fidelidad de las evaluaciones de
los trabajos



Modèles TP Reconstitution

Teeth models - Dentalabore - Dientes

Ref.	€HT
42/1700	140,04

Echelle x3,5
Scale



8 dents haut, gauche n°21 à 28 + 8 dents bas gauche n°31 à 38

8 upper left teeth + 8 lower left teeth

8 obere Zähne links + 8 untere Zähne links

8 dientes superiores + 8 dientes inferiores

Ces dents sont conformes aux caractéristiques morphologiques. Elles facilitent l'étude des formes des dents et sont destinées aux écoles dentaires, aux laboratoires de prothèse et à l'information des patients.



These teeth are representative of the morphological characteristics of natural teeth. They facilitate the study of teeth's anatomy and will suit the needs of universities, dental laboratories and patient education.



Diese Zähne dienen der morphologischen Analyse. Hervorragendes Studienmodell der Zahnformen. Speziell geeignet für Dentalabore, Schulen im Dentalbereich aber auch zur Patienteninformation



Estos dientes son adecuados para las diferentes características morfológicas. Facilitan el estudio de las formas de los dientes y están destinados a las escuelas de odontología, los laboratorios de prótesis y la información de los pacientes.

Le support pour **modèles de travaux pratiques** permet de fixer les modèles et de les **orienter** en fonction de la partie travaillée.
 Il s'adapte sur tout support (bureau, table...) sans le détériorer.

MODELES

Support pour Modèles TP implantologie
 Stand for Implantology models - Implantología modelos

Ref. € HT
 35/0377M 63,44



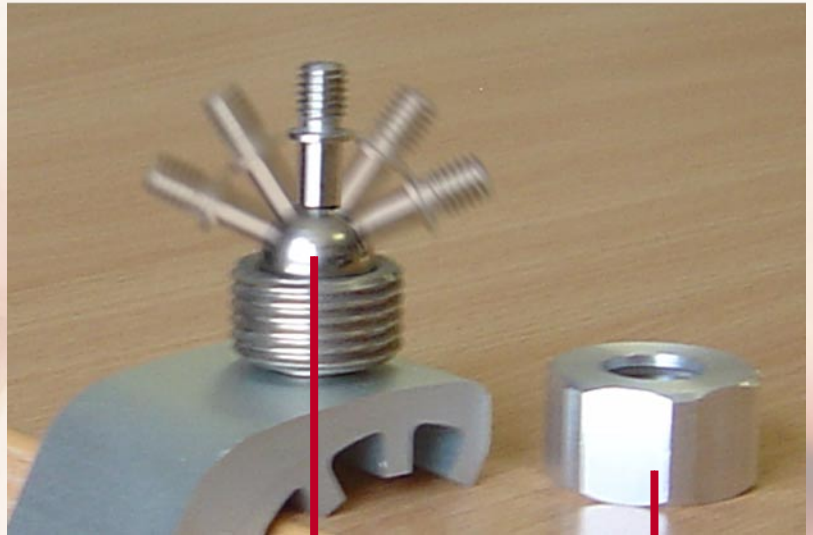

Support



Vis orientable pour modèle

Bague de serrage

-  **The bench stand** provides ease of use of implantology models: screw the stand on the bench, screw the model on the stand, direct the model freely and set the working position by fastening the bolt.
-  **Der Halter für Trainingsmodelle** erlaubt den sicheren Halt während der Arbeit und die Orientierung des Modells je nach Bedarf. Der Halter kann überall befestigt werden (Tisch, Büro, u.s.w.).
-  **El soporte para los modelos de trabajo** permite fijar los modelos y orientarlos en función de la parte a trabajar. Se adapta fácilmente a mesas o escritorios sin dañarlos (con tornillo orientable, anillo de cierre).

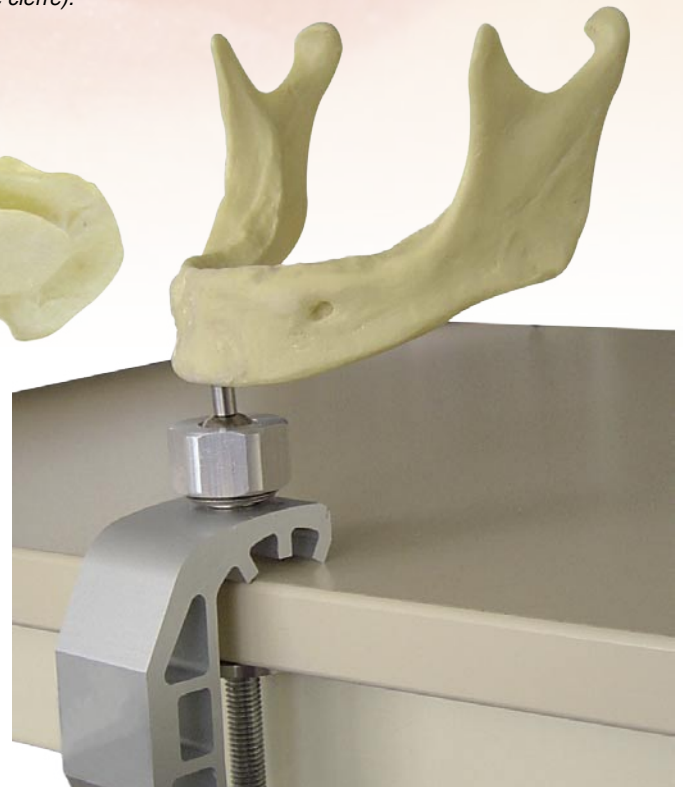



41/0980
N°1



41/0981
N°2



41/0982
N°3



41/0983
N°4

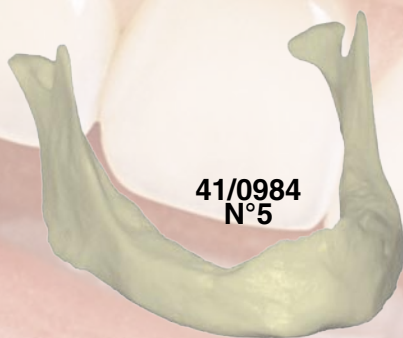

41/0984
N°5



41/0987

41/0985
Jeu 5 mandibules
n°1-2-3-4-5
 5 mandibles set
 5 UnterkieferformenSet
 Estucho de 5 mandibulas

Ref.	€ HT
FT41/0980	24,40
FT41/0981	24,40
FT41/0982	24,40
FT41/0983	24,40
FT41/0984	24,40
FT41/0985	105,03
FT41/0987	185,66
FT41/0993	41,38

Ces mandibules sont destinées aux études d'implantologie et de chirurgie faciale.
 les 5 types de mandibules façon os représentent des stades différents de résorption osseuse.
 La mandibule transparente montre la position des 16 dents anatomiques.

41/0993
Mandibule avec couche de silicone
Mandible with silicone surface
Unterkieferformen mit Silikon
Mandibula con silicona



These mandibles are suitable for implant and facial surgery studies.
 5 types of bone fashion mandibles demonstrate various patterns of bone resorption.
 The transparent mandible shows 16 anatomical teeth.



Diese Modelle können für Studienzwecke in der Implantologie sowie der Kiefer- und Gesichtschirurgie verwendet werden.
 5 Unterkieferformen, die die verschiedenen Stadien der Knochenresorption darstellen.
 1 Unterkiefer aus transparentem Kunststoff mit 16 anatomischen Zähnen



Estos modelos de mandíbulas son adecuados para los estudios de implantología y cirugía facial.
 5 tipos de mandíbulas que representan los distintos estadios de resorción ósea.
 1 mandíbula de resina transparente que muestra la posición de los 16 dientes anatómicos.

Les mandibules façon os et les modèles sinus sont particulièrement adaptés à la pose d'implants.

Ils sont traités pour restituer fidèlement les sensations du geste chirurgical.



41/09103



41/09103G

Avec gencive / With gum
Mit Zahnfleisch / Con encia

Ref.	€HT
41/09103	16,44
41/09103G	54,11
41/0991	24,40
41/0991G	59,41
41/0990	41,38
41/09901	41,38
41/09901G	85,93
41/0995G	68,96

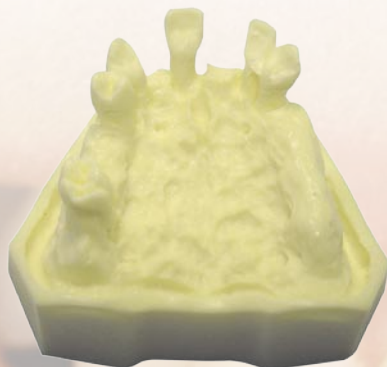

41/0991

Sans gencive / Without gum
Ohne Zahnfleisch / Sin encia



41/0991G

Modèles sinus avec alvéoles

Sinus models with alveolas/ Sinusmodelle mit Alveolen/ modelos de senos con alveolos



41/0990



41/09901



41/09901G



41/0995G



The bone imitation mandibles and sinus models are specifically designed for implant insertion training and restore the feel of the surgical gesture.



Die Unterkiefer sowie Sinusmodelle nach Knochenart, wurden insbesondere zur Schulung für das Einsetzen von Implantaten entwickelt. Diese Modelle sind so erstellt, dass sie das Gefühl des chirurgischen Eingriffs getreu wiedergeben.



Las mandíbulas modelo de hueso y los modelos de seno se adaptan especialmente a la realización de implantes. Se la utiliza para restablecer exactamente las sensaciones del gesto quirúrgico.

Modèle sinus partiellement édenté

avec arcades et écrou de fixation - Avec ou sans membrane sinusienne

Partially edentulous sinus model with/without membrane, with/without screw

Sinusmodell, Zahnverlust, mit/ohne Membrane

Modelo de seno, con/sin membrana

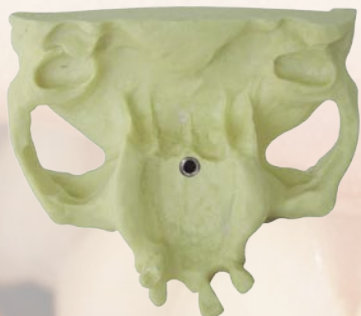

41/0992

Sans membrane

Without membrane / ohne Membrane / sin membrana

41/0992M

Avec membrane

With membrane / mit Membrane / con membrana

Ref.	€ HT
41/0992	91,98
41/0992M	126,88

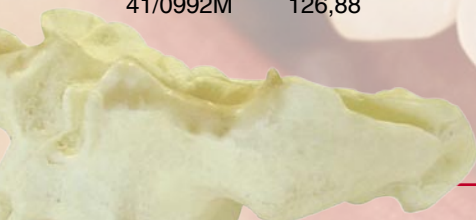

Modèle sinus totalement édenté avec arcades

Avec ou sans membrane sinusienne - Avec ou sans écrou

Totally edentulous sinus model with/without membrane, with/without screw

Sinusmodell, Zahnverlust, mit/ohne Membrane

Modelo de seno, con/sin membrana



41/0997

Sans membrane

Without membrane / ohne Membrane / sin membrana

41/0997M

Avec membrane

With membrane / mit Membrane / con membrana



41/0998

Modèle demi-sinus

Avec membrane sinusienne

Totally edentulous half-sinus model with membrane / Sinusmodell, Zahnverlust, mit Membrane / Modelo de seno, con membrana

Ref.	€ HT
41/0997	91,98
41/0997M	126,88
41/0998	59,20

Modèle de démonstration transparent rigide, idéal pour présenter vos implants en situation.



Ref. € HT
FT41/0 118,45

Prix de base sans implant
Price without implants

Fabrication sur demande
Manufactured upon request / Auf Anfrage / A petición



The transparent model base can receive your own implants for demonstration purpose.



Für eine Vorbereitung ohne Fehler des Einsetzens von Implantaten : das transparente Modell mit 5 Implantaten, erlaubt die Simulation der Implantation. Verfügbar entweder zahnlos, oder mit teilweiser Bezahlung.



Para una preparación segura de la intervención implantaria, el modelo transparente 5 implantes permite simular la colocación de un implante. Disponible en destentado total o parcial.



Fabrication sur Demande
Manufacture upon request

Toute fabrication sur demande de prototypes non suivie d'une commande entraîne **une facturation forfaitaire de 95€.**

Any model manufactured upon request will be **charged €95** unless it becomes part of an order.

Modell-Prototypen, die kundenspezifisch angefertigt wurden, werden mit einem pauschalen Betrag von **95 € berechnet**, wenn kein Auftrag folgt.

Toda fabricación de prototipos no seguida de un pedido supone una **facturación forfetaria de 95 €.**

Designation	Page	Designation	Page	Designation	Page	Designation	Page
ADAMS, Pincés	85, 105	Disques abrasifs pour zircone	107, 120	MILLER COLBURN, râpe à os	74	RHEIN, Sondes	16
Adaptateur outils contre angle	81	DMS, Miroirs	7	MILLER, précelle	31	ROACH	108
ADERER, Pincés	84, 102	EASYCLIP, cassette	93	MILLER, précelle papier	89	ROMEROWSKI, amalgames	23
ADSON, précelle	61, 74	Ecarte-joues	10, 90	MINIFLAM	130, 131	ROOS, Décolleur	8, 42, 76
Aiguilles, chalumeau	133, 136	Ecarteurs	72	Miroirs	5	SAUZEAT, Pincés	103
Alginate, mélangeur	83	Ecarteurs d'os	68	Miroirs, DMS	7	SCHWARZ, Pincés	103
ALLIS, Pince hémostatique	64	Élévateurs	46-51	Miroirs, double face	7	Séquenceur de fraises	91
ANDRESEN, Pincés	84, 105	Elevateurs de sinus	77, 79	Miroirs, gradués	6, 78	SHURE, enfonce bague grattoir	87
ANGLE, Pincés	85, 105	Excavateurs	26, 27	Miroirs, HOLY CLAR	7	Simulateurs endo	149
Antibulée	6	Extracteur de vis	80	Miroirs, laryngiens	9	Sondes	16, 37
Articulateur	99	Extracteurs d'implants	80	Miroirs, manches	14	Sondes, graduées	37
Bac à ultrasons	124	FALCON, cuillère à os	73, 79	Miroirs, micro	9	Spatule	88, 91, 113
BACKHAUS, Pince à champs	64	FANHSTOCK, couteau à cire	89, 111	Miroirs, photographiques	11	Spatule à ciment	106
Bagues, enfonce bagues	87	FARABOEUF, Ecarteurs	72	Miroirs, photographiques, manche	10	Spatule à cire	108
BARRY, élévateurs	46	Fers à souder	135	Miroirs, PURE REFLECT	5	Spatule à cire, Liberty Sculpt Lab	96, 97
BENNETT, Brunissoirs	25	FLAGG, Précelles	17	Modèle démonstration PFCE	142	Spatule à fil	87
BENQUE, Décolleur	77	FOC, amalgames	21	Modèle démonstration PFM16	145	Spatule, plâtre	88, 91, 113
BERNARD, Syndesmotosomes	44, 45	Fond de cavité, instrument	24	Modèle démonstration PFM3	140	Spatules, ciment	28, 29
Bigorne	115	FORMABRILL	115	Modèle démonstration PFM4	141	Spatules, composites	18
Bistouri	36, 40, 66	FRAHM	106	Modèle démonstration, enfant	82, 146	Spatules, obturation & modelage	18-20
Bistouri, Liberty Sculpt Lab	96, 97	FURRER, Pincés	103	Modèle d'étude, dents amovibles	148	SPENCER, Ciseaux	59
Boc fils	90	Gaz & oxygène	133, 137	Modèle paro	154	STYLOFLAM	126
Bols à plâtre	88, 91, 112	Godets DAPPEN	28, 91	Modèle pério	153	Support endodontique	91
BOYD WALLIS, Spatules, obturation & modelage	20	Godets silicone	91	Modèle taille de prothèse	155	Suture, précelle	43, 61
Brasure	136	GOLDMAN FOX, Ciseaux	58	Modèle support	156	Syndesmotosomes	44, 45
BREWER, Pincés	86	GOLDMAN FOX, Curettes	37	Modèles édentés partiels	150	THERMOCOUPLE	129
BRIAULT, Sondes	16	GOLDMAN FOX, précelle à marquer	42, 61	Modèles édentés partiels	150	Brûleur	
Bride	114	GOLDMAN-FOX, Décolleur	77	Modèles édentés partiels	150	THORPE, Détartreurs	34
Brûleur HOLY	128	GOSLEE, Pincés	101	Modèles sinus	158, 159	Tournevis	79
Brûleurs	128-130	GRACEY, Curettes	38, 39	Modèles, cube cristal	139	TOWNER, Détartreurs	34
Brunissoirs	25	Gratte-brosse	92	MOLT, Décolleur	42, 77	TWEED, Pincés	84, 105
Butées	72	HALSTEAD-MOSQUITO, Pince hémostatique	63	Mortier à os	73	TYPODONT, modèle démonstration enfant	82, 89, 147
Canules	6	HEIDEMANN, Spatules, obturation & modelage	18	MORTONSON, amalgames	21	UWD, amalgames	23
Cassette	93	HEMINGWAY, Curettes tranchantes	57	MOSQUITO, Pince hémostatique	63	VALLORBE, lime	115
Cassette implantologie	78	HOLLINOX	92	MOSQUITO, Pincés	103	VIGNAL, Elévateurs	50, 51
CASTROVIEJO, Ciseaux	59	HOLLOW CHOP, Pincés	85, 105	Moufles	114	WALDSACHS, Pincés	85, 101
CASTROVIEJO, Compas	73	HOLY Brûleur	129	Moules à empreintes	117	WARD	106
CASTROVIEJO, porte aiguille	43, 65, 75	HOLY CLAR, Miroirs	7	NEUMANN, Ciseaux	59	WARWICK-JAMES, élévateurs	45
CHOMPRET, Curettes tranchantes	56	HOURIGAN, Décolleur	77	NOYES, Ciseaux	59	WEDELSTAEDT, ciseau à émail	36
CHOMPRET, Syndesmotosomes	45	HOW, Pincés	85, 100	NPH, Spatules, obturation & modelage	19	WEINGART, Pincés	85, 105
Cire	89, 118, 119	IDI, Détartreurs	34	Obturation	18-22	WESTCOTT, amalgames	20
Ciseau à émail	36	INA, Détartreurs	35	OLIVIER, Pincés	105	WESTCOTT, Brunissoirs	25
Ciseau plat	115	INH, Détartreurs	34	Onglette plate	115	WESTON, Sondes	16
Ciseaux	58-60, 74	Injecteurs	136	ORBAN, bistouri	36	WHITE, Excavateurs	27
Ciseaux à couronnes	86, 104	ISOFLAM, pâte	136	Ostéotomes	69-71	WHITE, Spatules, obturation & modelage	18
Ciseaux à os	67	IWANSON, compas	116	PALMER, Pincés	86	WILLIAM, Sondes, graduées	37
CK6, Détartreurs	39	JAUQUETTE, Détartreurs	34	pansement, instrument	24	WOODSON, Spatules, obturation & modelage	20
Clavettes	114	JLM6ED, amalgames	20	PEAN, Pince hémostatique	63	YOUNG, Pincés	84
Clé dynamométrique	81	JOHNSON, Pincés	100	PEESO, Pincés	100	YOUNGER GOOD, Curettes	37
CLEOID, amalgames	23	JOSEPH, Ciseaux	58	PERRY, Précelles	17	ZAHLE	109
COLLEGE, Précelles	17	KIRKLAND, Bistouri	41	PFFID, Spatules, obturation & modelage	18	ZALHE, Liberty Sculpt Lab	96, 97
Compas	73, 116	KIRKLAND, Détartreurs	34	Pied à coulisse	90, 116	ZERFING, Détartreurs	34
Container brûleurs	130	Kits examen et soins	15	Pince à coulisse	64		
CORN, Précelle à suture	43, 61	KOCHER, Pince hémostatique	64	Pince à champs	64		
Couronnes, ciseaux	86	KOLINSKY, pinceaux	98	Pince à cylindre	114		
Couronnes, dépose couronne	30	KOPP, élévateurs	47	Pince à tenons	31		
Couronnes, enfonce couronne	30	LABOFLAM	128	Pince coupante	104		
Couteau à événements	30	LADMORE, amalgames	20	Pince coupante pour modèles	112		
Couteau à plâtre	113	LAGRANGE, Ciseaux	59, 74	Pince crocodile	137		
ROSEWOOD		Lampe à alcool	115	Pince hémostatique	63		
Crâne	139, 151	LECRON	108	Pinceaux KOLINSKY	98		
CRILE WOOD, porte aiguille	75	LECRON, Liberty Sculpt Lab	96, 97	Pincés	84, 85		
CRILLE, Pince hémostatique	63	LIBERTY SCULPT, instr. Labo	96, 97	Pincés plates	101		
CRILLE, Pincés	103	Lime	115	Pincés pour pièce zircone	107		
Cuillère à os	73	Lime, manches	115	Pincés, plâtre	88, 112		
Cupules	73	LSP, Spatules, obturation & modelage	18, 19	PKT	109		
Curettes	37-39	LUCAS, Curettes tranchantes	57	PKT, Liberty Sculpt Lab	96, 97		
Curettes tranchantes	56, 57	LUER-FRIEDMAN, pince gouge	57, 64	Plateau	93		
DAPPEN	28	Lunettes de protection	92	POLITZER, Maillet	72		
DARBY PERRY, Détartreurs	35	Luxateurs	47	Porte aiguille	43, 65, 75		
DARBY PERRY, Excavateurs	26	MAC CALL, Curettes	37	Porte-empreintes	32, 33		
DAUTREY, Ecarteurs	72	Maillet	67, 72	Pot à coton	92		
DAVENPORT, Détartreurs	34	MALLOTHY, Pincés	84, 102	Précelle	62, 74		
Daviers	52-55	MAMMOUTH, couteau	88	Précelle à céramique	110		
DEAN, Ciseaux	59	Mandibules	139, 157, 158	Précelle à marquer	42		
Décolleur, ROOS	8, 42, 76	Marteau	115	Précelle à marquer	61		
DENTALPRÉCI	109	Marteau, manches	115	Précelle à souder	110		
Dents	149, 155	MATHIEU, porte aiguille	43, 65, 75	Précelle à suture	43, 61		
Détartreurs	34, 35, 38	MATICFLAM	128	Précelle pour pièce zircone	107		
DEVIN, Détartreurs	34	MAYO, Ciseaux	60	Précelles	17		
DIRIGO, Spatules, obturation & modelage	19	MERIAM, Précelles	17	PRITCHARD, Décolleur	77		
Disques abrasifs	120-123	METZENBAUM, Ciseaux	59, 74	PROTORCH3	127		
Disques abrasifs diamantés	121	MICROTORCH, adaptateur bit. ind.	132,	Porte serviette	92		
		MICROTORCH, distributeur	136	PURE REFLECT, miroirs	5		
				QUIMBY, Ciseaux	59		
				Râpe à os	74		
				REEVES	109		
				Rétraction gingivale, instrument	24		
				REYNOLDS, Pincés	100		

Article	Page
Abrasive discs	120-123
Abrasive discs, diamond	121
Abrasive discs, zirconia	107, 120
ADAMS, Pliers	85, 105
Adapter for contra angle instruments	81
ADERER, Pliers	84, 102
ADSON, tweezers	61, 74
Alcohol lamp	115
Alginate mixer	83
ALLIS, Forceps, haemostatic	64
ANDRESEN, Pliers	84, 105
ANGLE, Pliers	85, 105
Anti-mist	6
Articulator	99
BACKHAUS, Towelclips	64
Band, band pusher	87
Bandage, instrument	24
BARRY, elevators	46
Beak irons	115
BENNETT, Burnishers	25
BENQUE, Elevator	77
BERNARD, Syndesmotosomes	44, 45
Bone chisel	67
Bone chisel	68
Bone curette	73
Bone files	74
Bone mixer	73
Bowls silicone	91
Bowls, for plaster	88, 91, 112

INDEX Alphabétique

Article	Page
BOYD WALLIS, Spatulas, filling	20
BREWER, Pliers	86
BRIAULT, Probes	16
Bur cleaning brush	92
Bur holder	91
Burner HOLY	128
Burners	128-130
Burnishers	25
Caliper	73, 116
Cannulas	6
CASTROVIEJO, Caliper	73
CASTROVIEJO, needle holders	43, 65, 75
CASTROVIEJO, Scissors	59
Cavity bottom, instrument	24
Cheek retractors	10, 90
Chisel, flat	115
Chisels, for enamel	36
CHOMPRET, Curettes, sharp	56
CHOMPRET, Syndesmotomes	45
CK6, Scalars	39
CLEOID, amalgam	23
Clip, revolving	137
COLLEGE, Tweezers	17
Container, Burners	130
CORN, Tweezers, suture	43, 61
Cotton wool holder	92
CRILE WOOD, needle holders	75
CRILLE, Forceps, haemostatic	63
CRILLE, Pliers	103
Crown remover	30
Crown scissors	86
Crown setter	30
Crucible tongs	114
Cupules	73
Curettes	37-39
Curettes, sharp	56, 57
DAPPEN	28
DARBY PERRY, Excavators	26
DARBY PERRY, Scalars	35
DAUTREY, Retractors	72
DAVENPORT, Scalars	34
DEAN, Scissors	59
DENTALPRÉCI	109
Denture flasks	114
DEVIN, Scalars	34
DIRIGO, Spatulas, filling	19
Dishes DAPPEN	28, 91
DMS, Mirrors	7
EASYCLIP, tray	93
Elevator, ROOS	8, 42, 76
Elevators	46-51
Endodontic holder	91
Excavators	26, 27
FALCON, bone curette	73, 79
FANHSTOCK, wax knife	89, 111
FARABOEUF, Retractors	72
Files	115
Files, handle	115
Filling instrument	18-22
FLAGG, Tweezers	17
FOC, amalgam	21
Forceps	52-55
Forceps, haemostatic	63
FORMABRILL	115
FRAHM	106
FURRER, Pliers	103
Gas & oxygen	133, 137
Gingival retraction, instrument	24
Glasses, protection glasses	92
GOLDMAN FOX, Curettes	37
GOLDMAN FOX, Scissors	58
GOLDMAN FOX, tweezers, pocket marker	42, 61
GOLDMAN-FOX, Elevator	77
GOSLEE, Pliers	101
GRACEY, Curettes	38, 39
HALSTEAD-MOSQUITO, Forceps, haemostatic	63
Hammer	115
Hammer, handle	115
HEIDEMANN, Spatulas, filling	18
HEMINGWAY, Curettes, sharp	57
HOLLEMBACK, amalgam	23
HOLLINOX	92
HOLLOW CHOP, Pliers	85, 105
HOLY Burner	129
HOLY CLAR, Mirrors	7
HOURIGAN, Elevator	77
HOW, Pliers	85, 100

Article	Page
IDI, Scalars	34
Implant extractors	80
Impression trays	32, 33
INA, Scalars	35
INH, Scalars	34
Injectors	136
ISOFLAM, paste	136
IWANSON, compass	116
JAQUETTE, Scalars	34
JLM6ED, amalgam	20
JOHNSON, Pliers	100
JOSEPH, Scissors	58
KIRKLAND, Scalars	34
KIRKLAND, Scalpel	41
Knife, plaster	113
ROSEWOOD	30
Knife, to remove silicone excess	30
KOCHER, Forceps, haemostatic	64
KOLINSKY, pencils	98
KOPP, elevators	47
LABOFLAM	128
LADMORE, amalgam	20
LAGRANGE, Scissors	59, 74
LECRON	108
LECRON, Liberty Sculpt Lab	96, 97
LIBERTY SCULPT, Lab instr.	96, 97
Lock pins	114
LSP, Spatulas, filling	18, 19
LUCAS, Curettes, sharp	57
LUER-FRIEDMAN, bone rongeur forceps	57, 64
Luxating instruments	47
MAC CALL, Curettes	37
Mallet	67, 72
MALLOTHY, Pliers	84, 102
MAMMOUTH, knife	88
Mandibles	139, 157, 158
MATHIEU, needle holders	43, 65, 75
MATICFLAM	128
MAYO, Scissors	60
MERIAM, Tweezers	17
METZENBAUM, Scissors	59, 74
MICROTORCH, adapter	132
MICROTORCH, distributor	136
MILLER COLBURN, bone files	74
MILLER, articulating paper forceps	89
MILLER, Tweezers	31
MINIFLAM	130, 131
Mirrors	5
Mirrors, DMS	7
Mirrors, double sided	7
Mirrors, handle	14
Mirrors, HOLY CLAR	7
Mirrors, laryngeal	9
Mirrors, micro	9
Mirrors, millimetric	6, 78
Mirrors, photographic	11
Mirrors, photographic, handle	10
Mirrors, PURE REFLECT	5
Model, carving	155
Model, demonstration, child	82, 146
Model, paro	154
Model, perio	153
Model, stand	156
Model, Study models with removable teeth	148
Models, crystal cubes	139
Models, demonstration	142
PFCE	145
Models, demonstration PFM16	140
Models, demonstration PFM3	141
Models, demonstration PFM4	150
Models, partially edentulous	158, 159
Models, sinus	42, 77
MOLT, Elevator	21
MORTONSON, amalgam	63
MOSQUITO, Forceps, haemostatic	103
MOSQUITO, Pliers	92
Napkin holder	43, 65, 75
Needle holders	133, 136
Needles, solder	31
Nerve instrument	59
NEUMANN, Scissors	59
NOYES, Scissors	19
NPH, Spatulas, filling	105
OLIVIER, Pliers	36
ORBAN, scalpel	69-71
Osteotomes	69-71

Article	Page
PALMER, Pliers	86
PEAN, Forceps, haemostatic	63
PEESO, Pliers	100
Pencils KOLINSKY	98
PERRY, Tweezers	17
PFID, Spatulas, filling	18
PKT	109
PKT, Liberty Sculpt Lab	96, 97
Pliers	84, 85
Pliers for zirconia	107
Pliers, cutting	104
Pliers, cutting, for models	112
Pliers, flat	101
Pliers, plaster	88
POLITZER, Mallet	72
Press	114
PRITCHARD, Elevator	77
Probes	16, 37
Probes, millimetric	37
PROTORCH3	127
PURE REFLECT, mirrors	5
QUIMBY, Scissors	59
REEVES	109
Retractors	72
REYNOLDS, Pliers	100
RHEIN, Probes	16
ROACH	108
ROMEROWSKI, amalgam	23
ROOS, Elevator	8, 42, 76
Root canal cubes	149
SAUZEAT, Pliers	103
Saw frame	90
Scalars	34, 35, 38
Scalpel	36, 40, 66
Scalpel, Liberty Sculpt Lab	96, 97
SCHWARZ, Pliers	103
Scissors	58-60, 74
Scissors, Crown scissors	86, 104
Screw remover	80
Screwdriver	79
Set, examination and care	15
SHURE, band pusher & cement scraper	87
Sinus lift	77, 79
Skull	139, 151
Sliding caliper	90, 116
solder	136
Soldering irons	135
Spatula	88, 91, 113
Spatula, cement	106
Spatula, plaster	88, 91, 113
Spatula, thread slot	87
Spatula, wax	108
Spatula, wax, Liberty Sculpt Lab	96, 97
Spatulas, cement	28, 29
Spatulas, composites	18
Spatulas, filling	18-20
SPENCER, Scissors	59
Stop	72
STYLOFLAM	126
Suture, Tweezers	43, 61
Syndesmotomes	44, 45
Teeth	149, 155
THERMOCOUPLE	129
Burner	34
THORPE, Scalars	81
Torque ratchet key	64
Towelclips	34
TOWNER, Scalars	93
Tray	93
Tray	117
Tray base	78
Tray, implantology	84, 105
TWEED, Pliers	62, 74
Tweezers	17
Tweezers, ceramic	110
Tweezers, pocket marker	42
Tweezers, pocket marker	61
Tweezers, soldering	110
Tweezers, suture	43, 61
Tweezers, zirconia	107
TYPODONT, child demonstration model	82, 89, 147
Ultrasonic cleaner	124
Ungula chisel	115
UWD, amalgam	23
VALLORBE, files	115
VIGNAL, Elevators	50, 51
WALDSACHS, Pliers	85, 101
WARD	106
WARWICK-JAMES, elevators	45
Wax	89, 118, 119
WEDELSTAEDT, enamel chisels	36
WEINGART, Pliers	85, 105
WESTCOTT, amalgam	20

Article	Page
WESTCOTT, Burnishers	25
WESTON, Probes	16
WHITE, Excavators	27
WHITE, Spatulas, filling	18
WILLIAM, Probes, millimetric	37
WOODSON, Spatulas, filling	20
YOUNG, Pliers	84
YOUNGER GOOD, Curettes	37
ZAHLE	109
ZALHE, Liberty Sculpt Lab	96, 97
ZERFING, Scalars	34

Artikel	Seite
Abdrucklöffel	32, 33
Absaugkanüle	6
ADAMS, Zangen	85, 105
Adapter für Winkelstück-Schraubendreher	81
ADERER, Zangen	84, 102
ADSON, Pinzetten	61, 74
Alginat, Mischgerät für	83
Alkohollampe	115
ALLIS, Klemmen, Arterienklemmen	64
Ambösschen	115
ANDRESEN, Zangen	84, 105
ANGLE, Zangen	85, 105
Anti Dunst	6
Artikulator	99
BACKHAUS, Tuchklemme	64
Bandsetzer	87
BARRY, Wurzelheber	46
Becher, für Gips	88, 91, 112
Becher, Silikon	91
BENETT, Brünierer	25
BENQUE, Raspatorien	77
BERNARD, Syndesmotome	44, 45
Bohrer-Bürste	92
Bohr-Ständer	91
BOYD WALLIS, Spateln, Füllung	20
Brenner	128-130
Brenner HOLY	128
BREWER, Zangen	86
BRIAULT, Sonden	16
Brille, Protektionsbrille	92
Brünierer	25
CASTROVIEJO, Nadelhalter	43, 65, 75
CASTROVIEJO, Scheren	59
CASTROVIEJO, Tasterzirkel	73
CHOMPRET, Küretten, Scharfe	56
CHOMPRET, Syndesmotome	45
CK6, Reiniger, Zahn-	39
CLEOID, Amalgam	23
COLLEGE, Pinzetten	17
Container, Brenner	130
CORN, Pinzetten, Naht-	43, 61
CRILE WOOD, Nadelhalter	75
CRILLE, Klemmen, Arterienklemmen	63
CRILLE, Zangen	103
Cupule	73
DAPPEN	28
DARBY PERRY, Exkavatoren	26
DARBY PERRY, Reiniger, Zahn-	35
DAUTREY, Wundhaken	72
DAVENPORT, Reiniger, Zahn-	34
DEAN, Scheren	59
DENTALPRÉCI	109
DEVIN, Reiniger, Zahn-	34
DIRIGO, Spateln, Füllung	19
DMS, Spiegel	7
Drehmoment Ratsche	81
EASYCLIP, tray	93
Endo Simulatoren	149
Exkavatoren	26, 27
FALCON, Knochenkürette	73, 79
FANHSTOCK, Messer, Wachse	89, 111
FARABOEUF, Wundhaken	72
Feilen	115
Feilen, Halter	115
FLAGG, Pinzetten	17
FOC, Amalgam	21
FORMABRILL	115
FRAHM	106
Füllungsinstrumente	18-22
FURRER, Zangen	103
Gas & Sauerstoff	133, 137
Glas DAPPEN	28, 91
GOLDMAN FOX, Küretten	37
GOLDMAN FOX, Scheren	58

Artikel	Seite	Artikel	Seite	Artikel	Seite	Designacion	Pagina
GOLDMAN FOX, Taschenmarkierung	42, 61	Modell, Übungsmodelle	155	TOWNER, Reiniger, Zahn-Tray	34	Casete, implantologia	78
GOLDMAN-FOX, Raspatorien	77	Modelle, Kindermodelle	82, 146	Tuchklemme	93	CASTROVIEJO, Calibradores	73
GOSLEE, Zangen	101	Modelle, Kristallwürfel	139	TWEED, Zangen	64	CASTROVIEJO, Porta agujas	43, 65, 75
GRACEY, Küretten	38, 39	Modelle, Sinusmodell	158, 159	TYPODONT Kindermodelle	84, 105	CASTROVIEJO, Tijeras	59
HALSTEAD-MOSQUITO, Klemmen, Arterienklemmen	63	Modelle, Studienmodelle, herausnehmbaren Zähnen	148	Ultraschallreinigung	82, 89, 147	Ceras	89, 118, 119
Halter für Nervnadeln	91	Modelle, Teilweisen Zahnverlust	150	Unterkieferformen	124	CHOMPRET, Curetas, cortantes	56
Hammer	115	Modellsockelformen	117	UWD, Amalgam	139, 157, 158	CHOMPRET, Syndesmotomos	45
Hämmer	67, 72	MOLT, Raspatorien	42, 77	VALLORBE, Feilen	23	Cinzel llano	115
Hammer, Halter	115	MORTONSON, Amalgam	21	VIGNAL, Wurzelheber	50, 51	Cinzel para hueso	67
Hartlot	136	MOSQUITO, Klemmen, Arterienklemmen	63	Wachse	89, 118, 119	Cinzel para hueso	68
HEIDEMANN, Spateln, Füllung	18	MOSQUITO, Zangen	103	WALDSACHS, Zangen	85, 101	Cinceles, para esmalte	36
HEMINGWAY, Küretten, Scharfe	57	Nadelhalter	43, 65, 75	Wangenhalter	10, 90	CK6, Limpiadores	39
HOLLEMBACK, Amalgam	23	NahtPinzetten	43, 61	WARD	106	CLEOID, amalgama	23
HOLLINOX	92	NEUMANN, Scheren	59	WARWICK-JAMES, Wurzelheber	45	COLLEGE, Pinzas	17
HOLLOW CHOP, Zangen	85, 105	NOYES, Scheren	59	Wattebehälter	19	Compas de corredera	90, 116
HOLY Brenner	129	NPH, Spateln, Füllung	19	WEDELSTAEDT, Schmelzmesser	92	Contenedor, Sopletes	130
HOLY CLAR, Spiegel	7	OLIVIER, Zangen	105	WEINGART, Zangen	36	CORN, Pinzas para sutura	43, 61
HOURIGAN, Raspatorien	77	ORBAN, Skalpelle	36	WESTCOTT, Amalgam	85, 105	Coronas, instrumento para colocar	30
HOW, Zangen	85, 100	Osteotome	69-71	WESTCOTT, Brünierer	20	Coronas, instrumento para quitar	30
IDI, Reiniger, Zahn-Implantaten-Extractor	34	PALMER, Zangen	86	WESTON, Sonden	25	Coronas, tijeras	86
INA, Reiniger, Zahn-INH, Reiniger, Zahn-Injektor	80	PEAN, Klemmen, Arterienklemmen	63	WHITE, Exkavatoren	16	Craneo	139, 151
ISOFLAM, Paste	35	PEAN, Klemmen, Arterienklemmen	63	WHITE, Spateln, Füllung	27	CRILE WOOD, Porta agujas	75
IWANSON, Tasterzirkel	116	PEAN, Klemmen, Arterienklemmen	63	WILLIAM, Sonden, graduierte	37	CRILLE, Alicates	103
JAQUETTE, Reiniger, Zahn-JLM6ED, Amalgam	34	PEAN, Klemmen, Arterienklemmen	63	WOODSON, Spateln, Füllung	30	CRILLE, Pinzas hemostaticas	63
JOHNSON, Zangen	100	PEAN, Klemmen, Arterienklemmen	63	Wundhaken	72	Cubetas	73
JOSEPH, Scheren	58	PERRY, Pinzetten	17	Wurzelheber	46-51	Cubetas para yeso	88, 91, 112
Kassette, Implantologie	78	PFID, Spateln, Füllung	18	Wurzerkanalinstrumente	31	Cuchillas, yeso, ROSEWOOD	113
Kautschuckstichel	115	Pinsel KOLINSKY	98	YOUNG, Zangen	84	Cuchillo, exceso de silicona	30
Kavitätsböden, Instrumenten	24	Pinzetten	62, 74	YOUNGER GOOD, Küretten	37	Cureta de hueso	73
Keilverschluss	114	Pinzetten	17	ZAHLE	109	Curetas	37-39
KIRKLAND, Reiniger, Zahn-KIRKLAND, Skalpelle	34	Pinzetten, Keramik	20	Zähnen	149, 155	Curetas, cortantes	56, 57
Klemmen, Arterienklemmen	63	Pinzetten, Lötpinzetten	110	Zahnverband, Instrumenten	24	DAPPEN	28
Knochenfeilen	74	Pinzetten, Naht-	43, 61	Zahnzangen	52-55	DARBY PERRY, Excavadores	26
Knochenkürette	73	Pinzetten, Taschenmarkierung	42	ZALHE, Liberty Sculpt Lab	96, 97	DARBY PERRY, Limpiadores	35
Knochenmeißel	67	Pinzetten, Zirkon	107	Zange, Orientierbare Zange	137	DAUTREY, Separadores	72
Knochenmeißel	68	PKT	109	Zangen für Zirkon	77	DAVENPORT, Limpiadores	34
Knochenmischdose	73	PKT, Liberty Sculpt Lab	96, 97	Zangen, Flachzangen	107	DEAN, Tijeras	59
KOCHER, Klemmen, Arterienklemmen	64	POLITZER, Hämmer	72	Zangen, Gips	101	DENTALPRÉCI	109
KOLINSKY, Pinsel	98	PRITCHARD, Raspatorien	77	Zangen, Schneide	88	Destornillador	79
KOPP, Wurzelheber	47	PROTORCH3	127	Zangen, Schneide, für Modelle	104	DEVIN, Limpiadores	34
Kronenabnehmer	30	PURE REFLECT, Spiegel	5	ZERFING, Reiniger, Zahn-Zurückziehen des Zahnfleisches, Instrumenten	112	Dientes	149, 155
Kronenscheren	86	QUIMBY, Scheren	59	Zylinder Zange	34	DIRIGO, Espatulas, obturacion	19
Kronensetzer	30	Raspatorien, ROOS	8, 42, 76		24	Discos abrasivos	120-123
Küretten	37-39	REEVES	109		114	Discos abrasivos, diamant	121
Küretten, Scharfe	56, 57	Reiniger, Zahn-REYNOLDS, Zangen	34, 35, 38			Discos abrasivos, zircono	107, 120
Küvetten	114	RHEIN, Sonden	16			DMS, Espejos	7
Küvettenbügel	114	ROACH	108			EASYCLIP, bandeja	93
LABOFLAM	128	ROMEROWSKI, Amalgam	23			Elevador de seno	77, 79
LADMORE, Amalgam	20	ROOS, Raspatorien	8, 42, 76			Elevadores	46-51
LAGRANGE, Scheren	59, 74	SAUZEAT, Zangen	103			Equipos, cuidado y examen	15
Laubsägebogen	90	Schädelmodell	139, 151			Espatula para cera, Liberty Sculpt Lab	96, 97
LECRON	108	Schale	93			Espatulas	88, 91, 113
LECRON, Liberty Sculpt Lab	96, 97	Scheren	58-60, 74			Espatulas para cemento	106
LIBERTY SCULPT, Lab. Instr.	96, 97	Scheren, Kronenscheren	86, 104			Espatulas para hilo	87
Lötdüsen	133, 136	Schiebelehre	90, 116			Espatulas, cementar	28, 29
LötKolben	135	Schleifinstrumente	120-123			Espatulas, cire	108
LSP, Spateln, Füllung	18, 19	Schleifinstrumente, diamond	121			Espatulas, composite	18
LUCAS, Küretten, Scharfe	57	Schleifinstrumente, Zirkon	107, 120			Espatulas, obturacion	18-20
LUER-FRIEDMAN, Holmeissenzangen	57, 64	Schraubendreher	79			Espatulas, yeso	88, 91, 113
Luxationsinstrumente	47	Schrauben-Extractor	80			Espejos	5
MAC CALL, Küretten	37	SCHWARZ, Zangen	103			Espejos, DMS	7
MALLOTHY, Zangen	84, 102	Serviettenhalter	92			Espejos, doble cara	7
MAMMOUTH, Messer	88	Sets, Diagnostik & Pflege	15			Espejos, fotograficos	10
MATHIEU, Nadelhalter	43, 65, 75	SHURE, Bandsetzer	87			Espejos, fotograficos, mango	11
MATICFLAM	128	Sinus Lift	77, 79			Espejos, graduados	6, 78
MAYO, Scheren	60	skalpel, Liberty Sculpt Lab	96, 97			Espejos, HOLY CLAR	7
MERIAM, Pinzetten	17	Skalpelle	36, 40, 66			Espejos, laryngeos	9
Messer, Gips, ROSEWOOD	113	Sonden	16, 37			Espejos, mangos	14
Messer, Schmelzmesser	36	Sonden, graduierte	37			Espejos, micro	9
Messer, Silikon-Abrucküberschuss	30	Spatel, Fadenfurche	87			Espejos, PURE REFLECT	5
METZENBAUM, Scheren	59, 74	Spatel, Zement	28, 29			Excavadores	26, 27
MICROTORCH, Adapter	132	Spateln	88, 91, 113			Extractor de implantados	80
MICROTORCH, Verteilerplatte	136	Spateln, Composite	18			Extractor de tornillo	80
MILLER COLBURN, Knochenfeilen	74	Spateln, Füllung	18-20			FALCON, cureta de hueso	73, 79
MILLER, Artikulationspapier pinzetten	89	Spateln, Gips	88, 91, 113			FANHSTOCK, cuchillas para ceras	89, 111
MILLER, Pinzetten	31	Spateln, Wachse	108			FARABOEUF, Separadores	72
MINIFLAM	130, 131	Spateln, Wachse, Liberty Sculpt Lab	96, 97			FLAGG, Pinzas	17
Modell, Demonstrationsmodell PFCE	142	Spateln, Zementspateln	106			FOC, amalgama	21
Modell, Demonstrationsmodell PFM16	145	SPENCER, Scheren	59			Fondo de cavidad, instrumentos	24
Modell, Demonstrationsmodell PFM3	140	Spiegel, DMS	7			Forceps	52-55
Modell, Demonstrationsmodell PFM4	141	Spiegel, doppelseitig	7			FORMABRILL	115
Modell, Halter	156	Spiegel, Fotospiegel	11			FRAHM	106
Modell, paro	154	Spiegel, Fotospiegel, Griffe	10			FURRER, Alicates	103
Modell, Perio	153	Spiegel, graduierte	6, 78			Gafas de proteccion	92
		Spiegel, Griffe	14			Gas y oxigeno	133, 137
		Spiegel, HOLY CLAR	7			GOLDMAN FOX, Curetas	37
		Spiegel, Kehlkopfspiegel	9			GOLDMAN FOX, pinzas para marcar	42, 61
		Spiegel, Mikro	9			GOLDMAN FOX, Tijeras	58
		Spiegel, Mundspiegel	5			GOLDMAN-FOX, Periostomo	77
		Spiegel, PURE REFLECT	5				
		Stichel, Flachstichel	115				
		Stop	72				
		STYLOFLAM	126				
		Syndesmotome	44, 45				
		Tasterzirkel	73, 116				
		THERMOCOUPLE Brenner	129				
		THORPE, Reiniger, Zahn-	34				

Designacion	Pagina
GOSLEE, Alicates	101
GRACEY, Curetas	38, 39
HALSTEAD-MOSQUITO, Pinzas hemostaticas	63
HEIDEMANN, Espatulas, obturacion	18
HEMINGWAY, Curetas, cortantes	57
HOLLEMBACK, amalgama	23
HOLLINOX	92
HOLLOW CHOP, Alicates	85, 105
HOLY CLAR, Espejos	7
HOLY Sopletes	129
HOURIGAN, Periostomo	77
HOW, Alicates	85, 100
Hueso, recipiente para mezcla de hueso	73
IDI, Limpiadores	34
Impulso	72
INA, Limpiadores	35
INH, Limpiadores	34
Inyector	136
ISOFLAM, pasta	136
IWANSON, compas	116
JAQUETTE, Limpiadores	34
JLM6ED, amalgama	20
JOHNSON, Alicates	100
JOSEPH, Tijeras	58
KIRKLAND, Bisturis	41
KIRKLAND, Limpiadores	34
KOCHER, Pinzas hemostaticas	64
KOLINSKY, pincel	98
KOPP, elevadores	47
LABOFLAM	128
LADMORE, amalgama	20
LAGRANGE, Tijeras	59, 74
LECRON	108
LECRON, Liberty Sculpt Lab	96, 97
LIBERTY SCULPT, Lab. Instr.	96, 97
Limas	115
Limas, mango	115
Limpiadores	34, 35, 38
Limpieza ultrasonica	124
Llave dinamométrica	81
LSP, Espatulas, obturacion	18, 19
LUCAS, Curetas, cortantes	57
LUER-FRIEDMAN, pinzas gubias	57, 64
Luxadores	47
MAC CALL, Curetas	37
MALLOTHY, Alicates	84, 102
MAMMOUTH, cucchillas	88
Mandibulas	139, 157, 158
Martillo	115
Martillo, mango	115
Martillos	67, 72
MATHIEU, Porta agujas	43, 65, 75
MATICFLAM	128
MAYO, Tijeras	60
Mechero de alcohol	115
MERIAM, Pinzas	17
METZENBAUM, Tijeras	59, 74
MICROTORCH adaptador	132
MICROTORCH, distribuidor	136
MILLER COLBURN, rallador de huesos	74
MILLER, Pinzas	31
MILLER, pinzas para papel de articular	89
MINIFLAM	130, 131
Modelo de seno	158, 159
Modelo, cubo cristal	139
Modelos de estudio, dientes intercambiables	148
Modelos para niños	82, 146
Modelos paro	154
Modelos perio	153
Modelos, caida parcial de dientes	150
Modelos, demostracion PFCE	142
Modelos, demostracion PFM16	145
Modelos, demostracion PFM3	140
Modelos, demostracion PFM4	141
Modelos, soporte	156
Modelos, tallado	155
Moldes a huella	117
MOLT, Periostomo	42, 77
MORTONSON, amalgama	21
MOSQUITO, Alicates	103
MOSQUITO, Pinzas hemostaticas	63
Mufias	114
NEUMANN, Tijeras	59
NOYES, Tijeras	59
NPH, Espatulas, obturacion	19
Obturaciones instrumentos	18-22
OLIVIER, Alicates	105

Designacion	Pagina
ORBAN, bisturis	36
Osteotomos	69-71
PALMER, Alicates	86
pasador	114
PEAN, Pinzas hemostaticas	63
PEESO, Alicates	100
Periostomo, ROOS	8, 42, 76
PERRY, Pinzas	17
PFID, Espatulas, obturacion	18
Pincel KOLINSKY,	98
Pinza orientable	137
Pinzas	62, 74
Pinzas	17
Pinzas de campo	64
Pinzas hemostaticas	63
Pinzas para ceramica	110
Pinzas para marcar	42
Pinzas para marcar	61
Pinzas para nervios	31
Pinzas para soldar	110
Pinzas para sutura	43, 61
Pinzas para zircone	107
PKT	109
PKT, Liberty Sculpt Lab	96, 97
Pocillos DAPPEN	28, 91
Pocillos, silicona	91
POLITZER, Martillos	72
Porta agujas	43, 65, 75
Porta moldes	32, 33
PRITCHARD, Periostomo	77
PROTORCH3	127
PURE REFLECT, espejos	5
QUIMBY, Tijeras	59
Rallador de huesos	74
REEVES	109
Retraccion de la encia, instrumentos	24
REYNOLDS, Alicates	100
RHEIN, Sondas	16
ROACH	108
ROMEROWSKI, amalgama	23
ROOS, Periostomo	8, 42, 76
SAUZEAT, Alicates	103
SCHWARZ, Alicates	103
Secuenciador de fresas	91
Separadores	10, 90
Separadores	72
Servilletero	92
SHURE, asentador de bandas	87
Sierra	90
Simuladores endo	149
Soldadores de estano	135
Soldadura	136
Sondas	16, 37
Sondas, graduados	37
Sopletes	128-130
Sopletes HOLY	128
Soporte endodontico	91
SPENCER, Tijeras	59
STYLOFLAM	126
Sutura, Pinzas	43, 61
Syndesmotomos	44, 45
Tenazas	114
THERMOCOUPLE Sopletes	129
THORPE, Limpiadores	34
Tijeras	58-60, 74
Tijeras para coronas	86, 104
TOWNER, Limpiadores	34
TWEED, Alicates	84, 105
TYPODONT, modelo para niños	82, 89, 147
Uneta llana fina	115
UWD, amalgama	23
VALLORBE, limas	115
Vendajes, instrumentos	24
VIGNAL, Elevadores	50, 51
WALDSACHS, Alicates	85, 101
WARD	106
WARWICK-JAMES, elevadores	45
WEDELSTAEDT, cinceles para esmalte	36
WEINGART, Alicates	85, 105
WESTCOTT, amalgama	20
WESTCOTT, Brunidores	25
WESTON, Sondas	16
WHITE, Espatulas, obturacion	18
WHITE, Excavadores	27
WILLIAM, Sondas, graduados	37
WOODSON, Espatulas, obturacion	20
YOUNG, Alicates	84
YOUNGER GOOD, Curetas	37
ZAHLE	109
ZALHE, Liberty Sculpt Lab	96, 97
ZERFING, Limpiadores	34



Conditions Générales de Vente

Nos marchandises voyagent aux risques et périls du destinataire même si le prix est établi franco. Celui-ci dispose d'un délai de 72 heures de leur réception pour introduire une réclamation valable. Aucun escompte n'est accordé pour paiement anticipé.

Toute commande implique l'adhésion à nos seules conditions générales de vente sans que l'acquéreur puisse de quelque manière y déroger. Aucune tolérance de notre société ne sera créatrice de droit. Nos obligations seront suspendues et notre responsabilité dérogée en cas de force majeure ou de cas fortuit.

En cas d'inexécution par l'acheteur de l'une de ses obligations et 8 jours après une mise en demeure par lettre recommandée avec A R sans effet, la vente sera résolue de plein droit, les marchandises seront restituées par l'acheteur à ses frais, sans préjudice de tous autres droits et recours.

A défaut de paiement à l'échéance contractuelle, les pénalités de retard exigibles seront calculées depuis la date d'échéance jusqu'au jour du paiement effectif à un taux égal à 3 fois le taux d'intérêt légal : ces pénalités seront payables à réception de l'avis informant l'acheteur qu'elles sont portées à son débit.

Nos traites ou acceptations ne font dérogation au lieu de paiement qui est le siège de notre société. En cas de litige, le Tribunal de Commerce dont dépend le siège de notre société sera seul compétent.

RESERVE DE PROPRIETE : Les marchandises restent notre propriété jusqu'au paiement intégral de la facture. Nos prix sont calculés pour paiement net sans escompte, franco de port à partir de 400 € H.T remises déduites.

Toute commande inférieure à 80 € net H.T sera majorée de 8 € pour frais de facturation.

Les factures sont payables à Vence. En cas de contestation, le Tribunal de Commerce de Grasse est seul compétent.

RETOURS : Aucune marchandise ne peut être reprise ou échangée sans notre accord préalable écrit. En cas d'acceptation, il sera décompté 10% pour frais. Toute commande spéciale ou ayant fait l'objet de marquage, ne pourra être reprise.

Indemnité forfaitaire pour frais de recouvrement: 40 euros. Si les frais de recouvrement sont supérieurs à ce montant forfaitaire, une indemnisation complémentaire sera due, sur présentation des justificatifs.



General Sales Conditions

Our goods are always carried at the buyer's risks, whatever Incoterm chosen, even franco. Any claims have to be made within a delay of 72 hours after receipt of the goods.

Each order is bound to our general sales conditions, which are the only valid ones. Any impairment from the buyer's side, by whatever means, is not acceptable. Any tolerance from our company will not give any further rights. Our obligations will be suspended and our responsibility disengaged in case of force majeure or fortuitous cases.

In case of non-performance by the buyer of one of his obligations and 8 days after a formal notice by registered letter with acknowledgement of receipt, remaining ineffective, the sale is annulated in full right, the goods have to be returned by the buyer at his charge, without any prejudice of all other rights and resorts.

In case of non-payment at the contractual due date, the penalties for overdue payable, will be calculated from the due date up to the date of the effective payment, to 3 times the legal rate of interest : these penalties are due at the receipt of the advice which informs the buyer that he has been debited with.

Our drafts or acceptances are not subject of impairments as to the place of payment which is the head office of our company. In case of contestations, the commercial court, which our head office depends on, is the only competent one.

PROPERTY CLAUSES : The goods remain our property until the full settlement of the same.

Settlement to be made in Vence. In case of contestation the commercial court in Grasse (France) is the only competent one.

Orders : Minimum order value : Euros 80.

Our prices are ex works, packing included. Each order is subject of an acknowledgement of order with indication of prices, delivery time, and payment terms.

RETURNS : Goods will not be taken back or exchanged without our preliminary written agreement. In case of acceptance, 10% of the returned goods value will be deduced for expenses. Any special orders, or orders which have been subject of marking, cannot be taken back.



Filiale du

GROUPE NADIA

1156, Route de la Sine 06140 Vence France

Tel. +33 (0)4 93 24 20 82 - Fax. +33 (0)4 93 24 68 26

Email: info@prodont-holliger.fr

www.prodont-holliger.com

SAS au capital de 285.000€ N° 572 168 979 RCS Grasse