



Attachments and Pre-fabricated Castable Components

CATALOG / TECHNICAL MANUAL
for Dentists and Dental Technicians



2013

W o r l d L e a d e r i n S p h e r i c a l A t t a c h m e n t s

1983 30° 2013
ANNIVERSARY

INDICATING COLOURS

to make catalogue reading easier

WHITE
background

CATALOGUE OF PRODUCTS

BLUE
background

INSTRUCTION FOR THE CLINIC

GREEN
background

TECHNICAL INSTRUCTION FOR THE LABORATORY

HOW TO GET TO OUR OFFICE



Metallic spherical attachments have been in existence for many years. But these attachments were not widely accepted, by the dental professionals. Then came the idea to render these mechanisms elastic! Smooth the head of the sphere and construct an elastic cap as a result of these innovative changes this technique to day is amongst the most widely used.

Rhein'83 has been in business since 1983 and today these products have been copied throughout the entire world, copies that in many cases reflect the forms of the objects but not the materials they are made from, and therefore it significantly changes the functional result.

Research is not only oriented towards the study of new products, but also continually trying to perfect those that have been used for many years.

Dental attachments are small mechanisms subjected to continuous movement, stresses and oral changing, requiring periodic maintenance and revisions. Some products in this have been made for maintaining and restoring the functionality, to all the prostheses, directly while they are in the mouth of the patients.

The commitment of Rhein'83 with its knowledge and skills continually being enriched by the contributions of dentists and laboratory technicians, is to be able to improve the actual standards and develop new products by means of original projects.

Ezio Nardi



HOW TO GET OUR OFFICE 1

RHEIN'83 INTRODUCTION 2

GENERAL INDEX 3

FRICTIONS AND RETENTIONS CONCEPT 4

FEMALE CAPS ASSORTMENTS 5

OT EQUATOR CASTABLE 6-7

OT EQUATOR FOR IMPLANTS 8-9

OT EQUATOR ELASTIC SEEGER 10-11

OT CAP SINGLE THREADED SPHERES 12-13

OT CAP & OT CAP TECNO - COMBINED PROSTHESES 14-15

OT BOX MONO 16

OT STRATEGY - COMBINED PROSTHESES 18-19

OT STRATEGY/STEADY 20

OT STRATEGY & OT CAP PROSTHETIC PROJECT 21

SINGLE SPHERES - OT CAP CASTABLE - OT CAP TITANIUM + TIN
DIRECT SYSTEM OVERDENTURES 22-23

S.P.L. TITANIUM POSTS FLEX - BLOCK
DIRECT SYSTEM OVERDENTURES - COPING COVER 24-25

OT BOX, CLASSIC - SPECIAL - CAST REINFORCEMENTS WITHOUT MODEL DUPLICATION 26-27

OT REVERSE 3 DIRECT SYSTEM OVERDENTURES 28-29

RECONSTRUCTIVE SPHERES: CONCAVE SPHERE 30

RECONSTRUCTIVE SPHERES: SOLID SPHERE 31

OT BAR MULTIUSE 32-33

OT VERTICAL 34-35

OT UNILATERAL 36-37

OT LOCK LOCKING PIN 38-39

IMPLANT OVERDENTURE ATTACHMENTS: SPHERO FLEX - BLOCK
DIRECTIONAL RINGS 40-41

IMPLANT OVERDENTURE ATTACHMENTS: UNIVERSAL "ANTI-UNSCREWING" SYSTEMS 42

MINI PARALLELOMETER DEVICE WITH MODEL HOLDER BASE
AND CUFF HEIGHT MEASURER 43

IMPLANTOLOGY: BROKEN SCREW EXTRACTOR FOR IMPLANTS FOR REMOVAL OF BROKEN IMPLANT
SCREWS 44-45

INSTRUCTION AND TECHNICAL ADVICE 46

ACRYLIC DEMONSTRATION MODELS 47

PRODUCT SPECIFICATIONS 48-49-50

KITS AND CODES 51-52-53-54-55

RHEIN'83 USA 56

HANDS ON COURSES ON RHEIN'83 PRODUCTS AND DIRECT SERVICES 57

Comparison of RIGID CAPS vs. ELASTIC CAPS

Characteristics and retentive functionality

FRICITION FIT CAPS:
RIGID MATERIALS
 • ACETALIC PLASTICS
 • METALS
 (thin layer)

Friction fit contact zone is very thin because of non-elastic material

FRICITION CONTACT ZONE
 With rigid materials, only minimal friction retention is achieved due to the smaller friction contact zone

FLEXION OF THE WALL
 With rigid materials, there is an "outward flex" of the wall of the cap

RIGID RESILIENCY
 In spite of the flat surface of the sphere, rigid materials do not allow vertical resiliency

RETENTIVE FIT CAPS:
ELASTIC MATERIALS
 • NYLON
 • TEFLON
 (thick layer)

The elastic materials permit a wide contact zone of retention at the equator and lower radius of the sphere

RETENTIVE CONTACT ZONE
 With elastic materials, greater friction and mechanical retention is achieved with a higher degree of functionality

COMPRESS AND RETURN
 With elastic materials, the wall of the cap is compressed and then returns to its original shape

VERTICAL RESILIENCY
 The space between the flat surface of the sphere and elastic cap allows for vertical resiliency and reduces stress

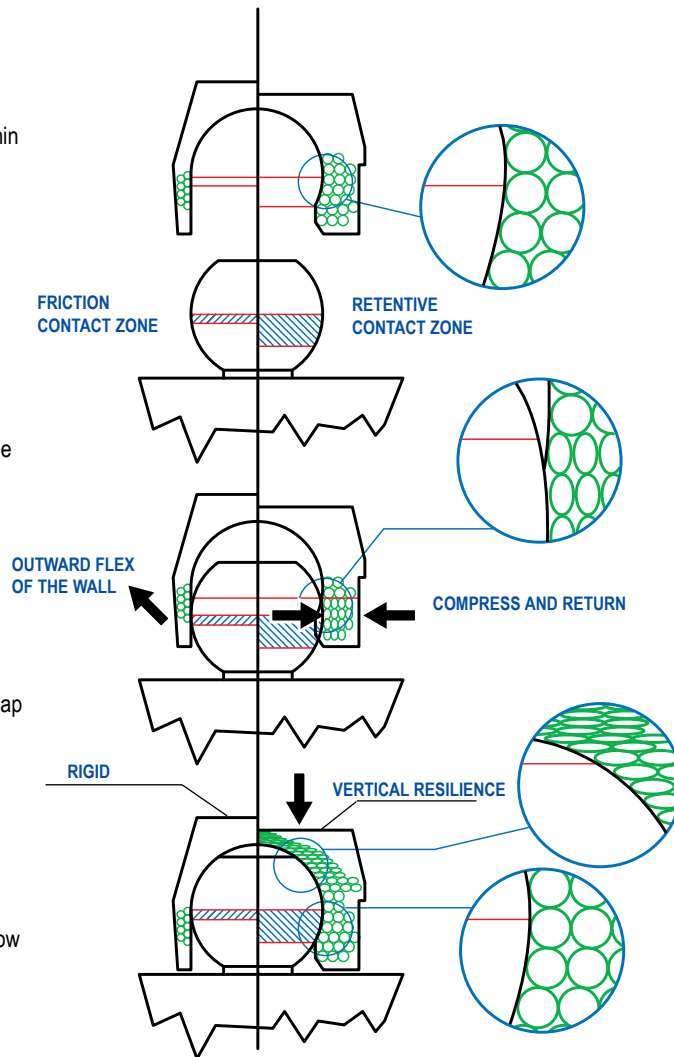

RHEIN83 - DESIGN AND FUNCTION

Rhein83 continues to manufacture female caps with elastic retention with the intention of eliminating as much vertical stress and trauma to the restoration as possible. For Rhein83 the important thing is to make a system of components available to the dental technician and dentist that will allow for the fabrication of a rigid, shock absorbing or resilient prosthesis. With the use of elastic retention, the function of Rhein83 attachments are extended.

With overdenture prosthetic devices or cases involving edentulous saddles, resiliency can be controlled with a wide range of retentive caps that have various levels of elasticity and retention.



Vertical movement



Rigid retention

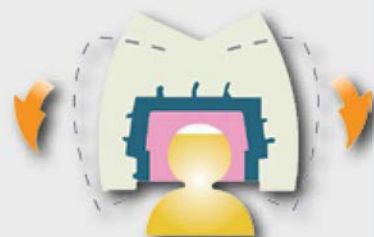

Movement in all directions

CLASSIC CAPS SIZES AVAILABLE: NORMAL AND MICRO

Retentive cap colors and retention

CLEAR CAPS

STANDARD RETENTION



Slightly Elastic

Maximum suggested time of duration in mouth: 12 months
Retention in grams: Normal from 1200 to 1300 gr. / Micro from 1000 to 1100 gr.

PINK CAPS

SOFT RETENTION



Elastic

Maximum suggested time of duration in mouth: 12 months
Retention in grams: Normal from 800 to 950 gr. / Micro from 750 to 850 gr.

YELLOW CAPS

EXTRA SOFT RETENTION



Very elastic

Maximum suggested time of duration in mouth: 12 months
Retention in grams: Normal from 500 to 550 gr. / Micro from 450 to 500 gr.

GREEN CAPS



Characteristics:

Extremely elastic retention, "GUMMY" type. Minimally hydroscopic, with a good adhesion on the sphere.

EXTRA RESILIENT GOLD CAPS

SLIGHTLY ELASTIC



Characteristics:

To be used in overdenture prostheses, where resilience and vertical movements are necessary.

Retention in grams: Normal from 450 to 500 gr. / Micro from 250 to 300 gr.

EXTRA RESILIENT SILVER CAPS

ELASTIC AND GUMMY



Characteristics:

To be used in overdenture prostheses, where a vertical movement is necessary and a light initial retention is requested.

PROCESSING CAPS



Characteristics:

Caps to be used only for laboratory processing.

TITAN CAPS

NYLON CAPS WITH INTERNAL TITANIUM RING



Characteristics:

Extremely durable. To be used especially in combination with pre-fabricated spheres such as titanium spheres, concave spheres, etc.

UNDERSIZED INTERNAL DIAMETER CAPS

STANDARD RETENTION



Characteristics:

Internal diameter reduced (Normal 2.2mm | Micro 1.6mm), for worn out sphere or 2.2mm - 1.6 sphere

UNDERSIZED INTERNAL DIAMETER CAPS

SOFT RETENTION



Characteristics:

Internal diameter reduced (Normal 2.2mm | Micro 1.6mm), for worn out sphere or 2.2mm - 1.6 sphere

STAINLESS STEEL AND TITANIUM HOUSING FOR CAPS, PRE-FABRICATED, NORMAL AND MICRO SIZES

THE NEW STAINLESS STEEL HOUSING DESIGN OFFER REDUCE SIZE AND ADDITIONAL STABILITY, IT CAN BE ENBODY DIRECTLY IN THE RESIN, WELDED OR BONDED TO THE FRAME.
THE NEW DESIGN IS ALSO AVAILABLE IN TITANIUM.

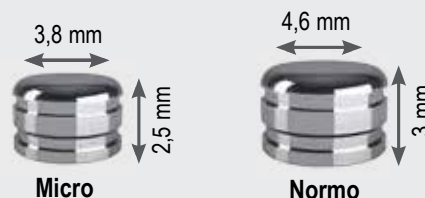

TITAN CAP

The TITAN cap is a nylon cap with an internal titanium ring that has an oblique cut around the circumference, that makes it elastic. It is able to pass, without any friction on the sphere, leaving the perimeter smooth for a long time. The lifetime of these caps is very long and they can be used with different prostheses, even in cases where there is an imbalanced prosthesis where the cap, made entirely from nylon produces unsatisfactory results.

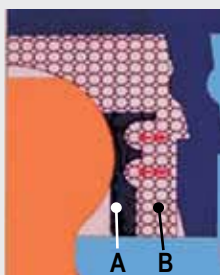

FUNCTIONAL CONCEPTS

- After a brief period of adjustment, the titanium ring maintains a steady retention.
- Over time, even with the wearing of the nylon, the titanium ring maintains constant compression and retention because it is enclosed between the titanium and the housing.

OT EQUATOR CASTABLE

Single Attachment for Overdentures



OT EQUATOR PROFILE CASTABLE
MALE
ATTACHMENT

RETENTIVE CAPS
OT EQUATOR



STAINLESS STEEL HOUSING



VIOLET CAP
RIGID RETENTION (2.7Kg)



CLEAR CAP
STANDARD RETENTION (1.8Kg)



PINK CAP
SOFT RETENTION (1.2Kg)



YELLOW CAP
EXTRA-SOFT RETENTION (0.6Kg)



BLACK CAP
PROCESSING



IMPRESSION
TRANSFER
pick-up impression



IMPRESSION
TRANSFER
individual tray



STAINLESS STEEL
ANALOG FOR
PLASTER MODEL



RETENTIVE CAP
INSERTION TOOL
NORMAL SIZE AND FOR "SEEGER"
RINGS



PARALLELOMETER
MANDREL

CLINIC

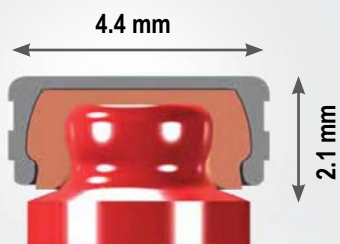

If additional retention is needed to secure the prosthesis, OT Cap Normal retentive caps and metal housings can be placed over any OT Equator Profile spheres. The prosthesis will be retained in the same way and the connection will be more rigid. Only the dimension of the attachment will be changed.



SEVERE DIVERGENCY MAY REQUIRE THE
OT EQUATOR IN COMBINATION WITH A
CASTABLE UCLA

LABORATORY

OT EQUATOR CASTABLE = SINGLE CASTING



Use separating material on the stone model in the prepared areas to receive the castable posts.



Use longer castable posts in the root channels for easy removal. Reline with castable resin, for higher accuracy.



Place posts and finish margins with composite material. Once resin is cured, cut posts to the required length at root level.



Position OT Equator on the occlusal surface with the paralleling key and continue waxing technique.



OT Equator in the final position. The wax-up has been completed.



For the best results, create the casting with an alloy that has a vickers hardness of 220 or greater.

BUILD UP THE FRAME DIRECTLY ON MASTER MODEL



The plaster model with the OT Equator analog in position. The stainless steel housing and black processing cap are also visible.



Apply a thin layer (.5mm) of wax to the model. Fill the undercuts on the stainless steel housing and attach the connectors.



Connect the parts using a castable resin. Be sure to cover the stainless steel housing.



Add sprues to the framework and remove it from the model. Be sure that the stainless steel housing does not remain inside. The framework is now ready to be invested.



Cast the metal frame and verify the position on the model.



Use composite to bond the stainless steel housing to the frame.



The metal frame with the stainless steel housing in place.



The finished prosthesis on metal frame. After processing, the black caps are replaced with pink caps.

OT EQUATOR FOR IMPLANTS

Low Profile Titanium Abutment



RETENTIVE CAPS OT EQUATOR



STAINLESS STEEL
HOUSING



VIOLET CAP
RIGID RETENTION (2.7Kg)



WHITE CAP
STANDARD RETENTION (1.8Kg)



PINK CAP
SOFT RETENTION (1.2Kg)



YELLOW CAP
EXTRA-SOFT RETENTION (0.6Kg)



BLACK CAP
PROCESSING



SQUARE SCREWDRIVER
1.25 MM
for implant abutment



SQUARE DRIVER CONNECTOR
1.25 MM
for contra angle torque controller



OT EQUATOR PROFILE
TITANIUM + TIN ATTACHMENT



IMPRESSION
TRANSFER
(pick-up impression)



IMPRESSION
TRANSFER
(individual tray)



STAINLESS STEEL
ANALOG FOR
PLASTER MODEL



INSERTION TOOL
FOR RETENTIVE CAPS
Normal size and for "Seeger" Rings



EXTRACTOR TOOL
FOR RETENTIVE CAPS

CLINIC

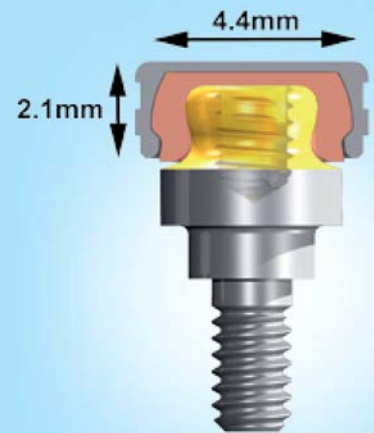

LABORATORY



The unique design and exceptionally low 2.1mm profile of the OT Equator 4 in 1 System provides exceptional stability and superior retention when compared with other attachment systems.

Due to its lower radius, OT Equator is indicated to correct divergence up to 28 degrees between implants without affecting the functionality of the elastic nylon cap.

Caps are available in a wide variety of retention levels.

ATTENTION; Where implant divergence exceed the maximum 28 degrees, Sphero Block and Sphero Flex are recommended case plan options.

See Sphero Block and Sphero Flex page 40-41

ATTACHING THE CAPS IN CLINIC



Select the OT Equator with the appropriate cuff height. Screw the OT Equator into the implant.



Place the protective disk over the OT Equator. Then, place the stainless steel housing with cap on the attachment.



Verify the positioning of the prosthesis before bonding the stainless steel housing with cap on the attachment.

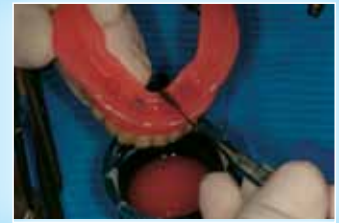

On the prosthesis, fill the implant sites with a self curing resin and insert into the patient's mouth.



Remove the prosthesis and verify that the positions of the attachments are correct.



Remove the protective disks.



Carefully trim away the excess resin.



The completed prosthesis.

IMPRESSION TRANSFER



Place the impression coping on the OT Equator.



The impression coping picked up in the impression.



Insert the analog into the impression coping and pour the master model.



Master model with analog in position.

BUILD UP THE FRAME DIRECTLY ON MASTER MODEL



Master model with OT Equator analog in position. Also pictured is the stainless steel housing with black processing cap.



Apply a thin layer (.5mm) of wax on the model. Fill the undercuts on the stainless steel housing with wax and attach the connectors.



Attach the parts using a castable resin. Be sure to cover the stainless steel housing.



Add sprues to the framework and remove it from the model. Be sure that the stainless steel housing does not remain inside.



Finish the metal frame and verify the position on the model.



Use composite to bond the stainless steel housing to the frame.



The metal frame with stainless steel housings bonded in place.



The finished prosthesis on metal frame. After processing the black caps are replaced with pink caps.

ELASTIC SEEGER

Passive bar connection

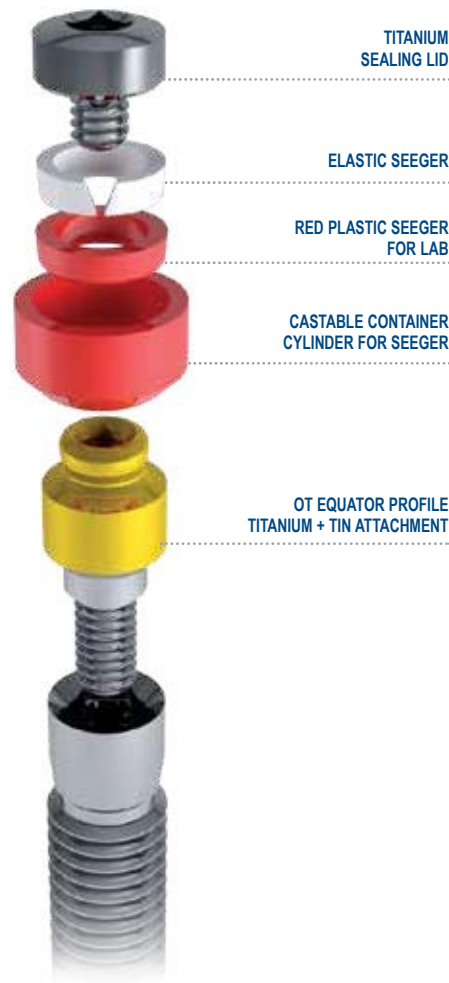

TITANIUM SEALING LID

ELASTIC SEEGER

RED PLASTIC SEEGER FOR LAB

CASTABLE CONTAINER CYLINDER FOR SEEGER

OT EQUATOR PROFILE TITANIUM + TIN ATTACHMENT



UNIVERSAL HANDLE curved for seeger inclusion



HEX SCREWDRIVER 1.3 MM for screwing attachments into implants



STAINLESS STEEL ANALOG for plaster model

The purpose of the OT Equator "seeger" system is to create a passive connection for implant supported bars. The elastic seeger will correct small imperfections created by the chairside impression technique or laboratory casting process. This reduces the risk of the implant bar not seating passively.

CLINIC

SECTION OF SEEGER INSERTION



THE ELASTIC SEEGER IS MANUFACTURED FROM A SPECIAL HARD PLASTIC WITH A CONICAL DESIGN. THE LOWER PART OF THE RING IS THINNER ADAPTING TO THE DESIGN OF THE ATTACHMENT.

LABORATORY



OT EQUATOR castable attachments for direct overdentures on endodontically treated roots



OT EQUATOR castable attachments are placed on the connecting bar creating a "balance" with the removable prosthesis. Alloys with a Vickers Hardness of 240 or greater are recommended for casting.

POSITIONING SYSTEM WITH BAR "ELASTIC SEEGER"



OT Equator titanium attachments screwed into the implants. The elastic seeger system will be used to position the bar.



The cast bar in position. Insert the white elastic seeger ring into the cylindrical space.



Using the insertion tool, push down on the white elastic seeger ring until it is fully seated.



A "click" will be heard once the seeger ring is seated over the OT Equator attachment. Remove any excess material to avoid creating a gap during the casting procedure.



After the elastic seeger ring has been inserted, lock the bar into place using the titanium screw cap and the appropriate key.



When the screw cap is tightened, the elastic ring is compressed which prevents unscrewing.



The finished bar secured in the mouth. A passive connection has been achieved due to the elastic seeger rings.



The completed prosthesis. For best results a reinforced superstructure is always recommended.

WAX-UP OF THE BAR DIRECTLY ON MODEL MASTER



Screw the OT Equator attachments into the implant analogs.



Position the seeger castable cylinders, followed by the red plastic seeger for laboratory use on the attachments. Screw the titanium sealing lid into position. Do not overtighten.



Connect the castable abutments with wax or resin.



Before casting, remove the red plastic seeger ring.



The cast bar in position on the model.



The cast framework in position. Undercuts on the stainless steel housing can be blocked out using composite material to maintain a passive connection.



Fit and stability of the prosthesis can be regulated using nylon caps. Various levels of retention are available.



The final prosthesis.

Interchangeable threaded Attachments with threaded sleeve system



NORMAL SPHERE
HEX 1.3 mm

MICRO SPHERE
HEX 0.9 mm

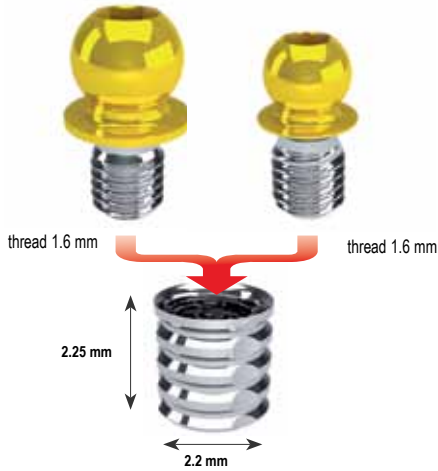

THREADED SLEEVE FOR BONDING



OT CAP SLEEVE SPACERS
Normal/Micro



HEX SCREWDRIVER
HEX 0.9 mm



HEX SCREWDRIVER
HEX 1.3 mm



RETENTIVE CAPS
OT CAP

Clear Standard Pink Soft Yellow Extra Soft Green Elastic Black Processing



METAL HOUSING
OT CAP NORMAL / MICRO

INSERTION TOOL FOR CAPS



NORMAL / MICRO
IN METAL HOUSING AND
IN THE PATIENT'S MOUTH

PARALLELOMETER KEY
Normal / Micro



RHEIN'83 COMPOSITE MATERIAL
Metal to Metal Bonding



OT EQUATOR SQUARE HEAD



thread 1.6 mm

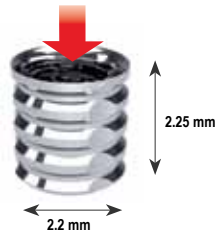

THREADED SLEEVE FOR BONDING



SCREWDRIVER
OT EQUATOR SQUARE



METAL HOUSING
OT EQUATOR



OT EQUATOR SLEEVE SPACER



RETENTIVE CAPS
OT EQUATOR

Violet Strong Clear Standard Pink Soft Yellow Extra Soft Black Processing

LABORATORY



OT Equator profile



OT CAP - OT EQUATOR FOR CAD-CAM MILLED BARS

NORMAL SPHERE



Standard
2 mm Thread

MICRO SPHERE



Standard
2 mm Thread

OT EQUATOR



Standard
2 mm Thread

STEP BY STEP THREADED SLEEVE BONDING PROCEDURE

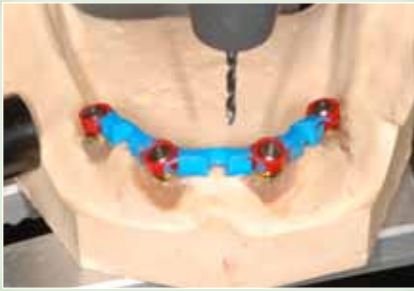

Once the bar has been connected with wax, create an area where the attachment spacer will be placed.



Apply separator to the base of the attachment spacer and position using the parallelometer key.



With the attachment spacer in position, complete the wax-up design.



Carefully remove the attachment spacers and proceed with the normal casting procedure.



Screw the threaded attachment of choice (Micro Ball shown) into the threaded sleeve.



Place the assembled attachment into the parallelometer key. Use a self curing metal to metal bonding composite on the sleeve and in the cylinder.



After the composite is cured, remove any excess material.



Unscrew the attachment to verify the threaded sleeve is securely bonded in place.



The finished bar complete with attachments.

3 ATTACHMENT OPTIONS

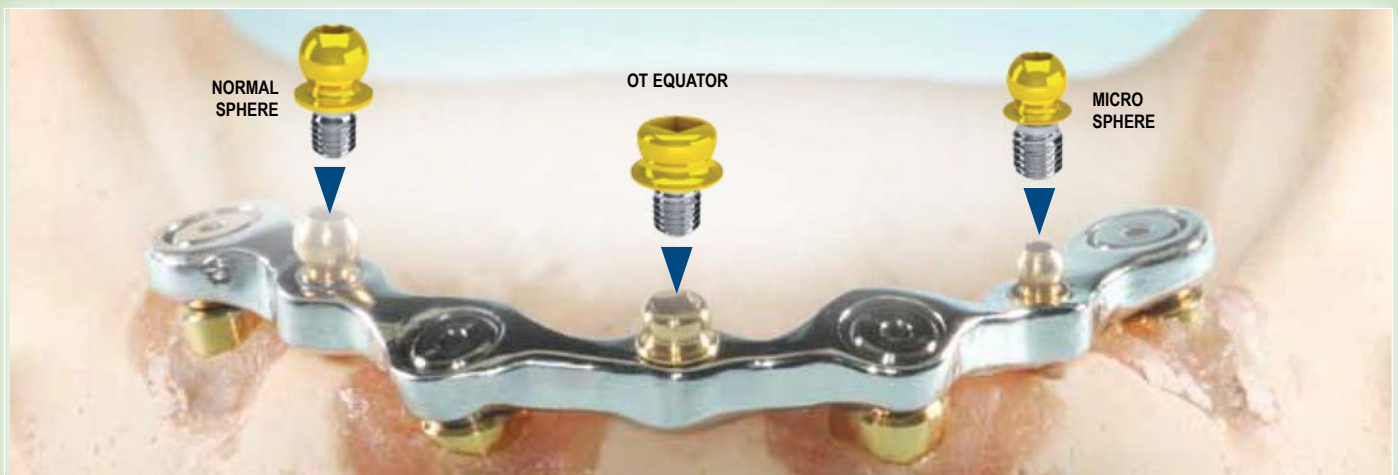

THE TECHNIQUE IS THE SAME FOR ALL THREE OPTIONS

EXTRACORONAL CASTABLE ATTACHMENTS

OT CAP - OT CAP TECNO



STAINLESS STEEL
AND TITANIUM HOUSINGS
Normal / Micro
for resin
or soldering



OT BOX MONO
Normal / Micro



RETENTIVE CAPS
Normal / Micro



TITANIUM + TIN
OVER 1600 VICKERS



CASTABLE BARS
Normal / Micro



OT CAP TECNO BARS
Normal / Micro

PARALLELOMETER
KEY FOR OT CAP
Normal / Micro



PARALLELOMETER
KEY FOR OT CAP TECNO
Normal / Micro



REGULATING TOOL FOR
RETENTION
Normal / Micro



INSERTION TOOL
FOR CAPS
Normal / Micro



TOOL FOR TESTING CAP
RETENTION
Normal / Micro



REMOVAL TOOL FOR
RETENTIVE CAPS



OT Cap is a resilient distal extension attachment. It is indicated to be used with combined prostheses and removable partial dentures.

For treatment plans that require a rigid substructure with milling and adequate counter attachments, OT Cap functions as a stabilizing retentive connector. In addition, for treatment plans which require resiliency, OT Cap provides a "Cushion Effect" similar to a shock absorber. This is achieved by the design of the sphere in conjunction with the elastic retentive caps.

The OT Cap Tecno consists of a titanium sphere and ring that is incorporated into the nylon cap which has been machined with a tolerance that assures high precision. While fabricating the prosthesis, the Tecno titanium sphere is not exposed to any of the risks associated with the laboratory fabrication procedures and ceramic firing cycles.

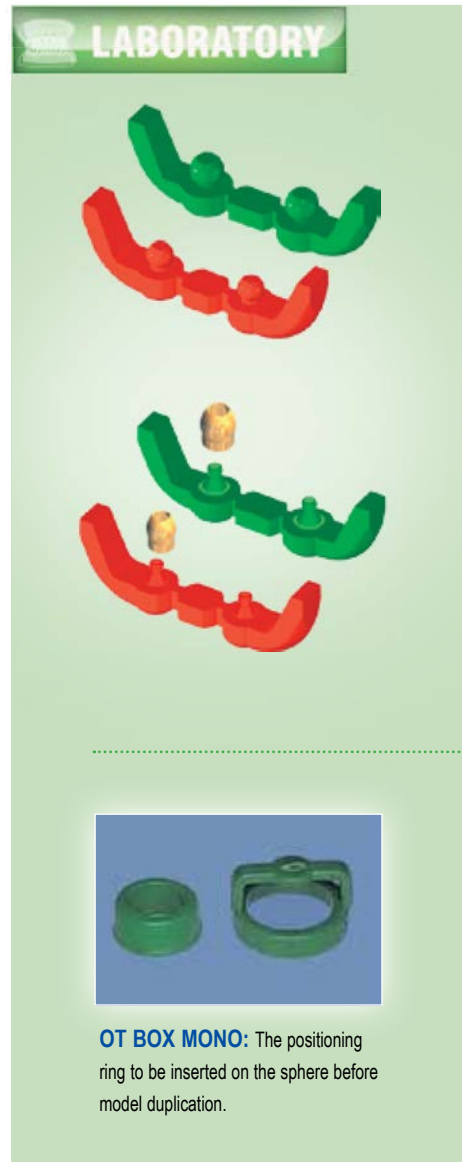

OT BOX MONO: The positioning ring to be inserted on the sphere before model duplication.

COMBINED PROSTHESES with extracoronary castable attachments

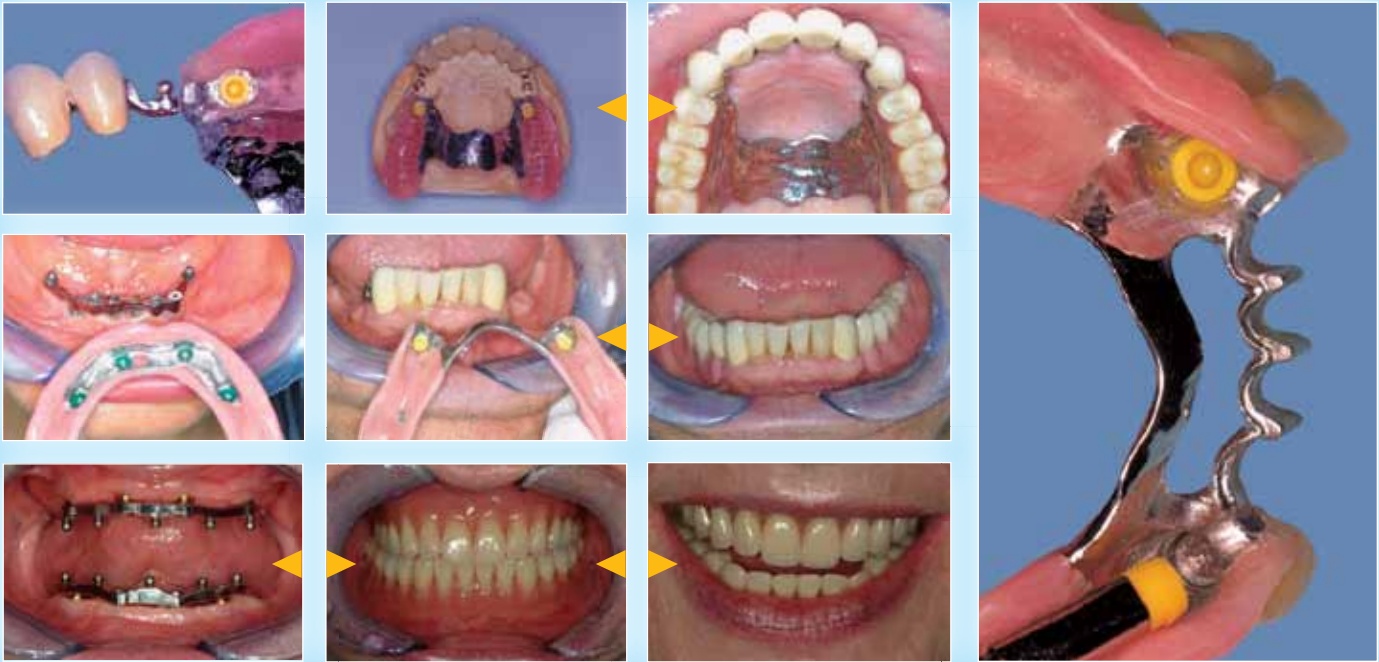

OT CAP CASTABLE



Cut the plastic bar and use only the section that you need.



Using the mandrel, position the spheres in parallel. Complete the wax-up with a "ledge" along the crown. The "ledge" must not be lower than the sphere.



The cast crowns. It is suggested to use a retentive cap to protect the sphere from excessive wear.



The cast attachment. The "ledge" along the crown helps select and redirect the vertical loads.

OT CAP TECNO



Separate the plastic bar.



Position the attachment in parallel using the OT Tecno mandrel.



Cast the attachment and polish. Do not polish the post or the sphere to allow for more retention.



Using anaerobic cement, attach the titanium sphere in parallel using the OT Cap mandrel.

OT MONO BOX - CAST HOUSING WITH DUPLICATED MODELS



The OT Cap positioning ring on the sphere.



The duplicated model in investment.



The OT Mono Box castable housing in position and incorporated into the final wax design.



The final OT Mono Box casting with retentive caps inserted into the housing.

The castable **OT MONO BOX** reproduces the shape of the housing which incorporates the retentive cap into the framework. Use the OT CAP insertion tool to place the retentive cap into the housing.



CASTABLE HOUSING

SINGLE HOUSING
Castable Normal size

POSITIONING RING



SINGLE HOUSING
Castable Micro size

POSITIONING RING



HOUSINGS:

STAINLESS STEEL - TITANIUM

The new stainless steel housing design offer reduce size and additional stability, it can be embdy directly in the resin, welded or bonded to the frame.

The new design is also available in titanium.

SIZE FOR RESIN OR SOLDERING



Micro



Normo

LABORATORY

When vertical space is limited, use reinforced pins to reduce the risk of breakage of the denture teeth.

SOLUTION A



Place a piece of .5mm calibrated wax over the wax-up design for additional protection.



The finished casting with retentive cap in place.

SOLUTION B



Small wax pins are added for reinforcement of the denture acrylic as well as additional retention for the denture teeth.



The final cast housing with reinforced metal pins.

STAINLESS STEEL PRE-FABRICATED HOUSINGS

For bonding or soldering to the frame

To obtain the right position use the **POSITIONING RINGS**.
NORMAL and **MICRO** sizes are available.



Rhein83 continues to be the world leader in spherical attachments and implant components. Largely due to continuous research and development, active participation in exhibitions as well as providing practical hands-on technical training for dentists and dental laboratory technicians. In addition, the company utilizes state of the art technology to constantly develop new products and improve existing product design as well as promote product awareness.

Rhein83 attachment systems are technically supported in over 75 countries worldwide.



Ezio Nardi
Founder

Claudia Nardi
President

Gianni Storni
VP Technology

CERTIFICATIONS:

Since 1996 Rhein83 has been operating with a quality control system that conforms to:

UNI EN ISO 9001:2008 Standards

UNI EN ISO 13485:2004 Standards

Directive 93/42/EEC

Rhein83 received this certification from Clementi, Italy, which is the certifying body for all activities associated with C€ certification.

That same year, the company passed the rigorous requirements for the United States Food and Drug Administration, permitting it to sell attachments and implant components in the United States market.

All of the components are designed, manufactured and sold with respect to the D.Lg 93/42.

CASTABLE VERTICAL ATTACHMENT MICRO

OT strategy
FOR
DUPLICATION
TECHNIQUE



OT strategy
FOR INSERTION INTO THE
PRE-FABRICATED HOUSING



CAPS

- Clear • Standard
- Pink • Soft
- Yellow • Extra Soft
- Black • Processing

STANDARD BASE
Sphere Ø 1.8 mm
LONG BASE
Sphere Ø 1.8 mm



ANALOG POST

CAPS

- Clear • Standard
- Pink • Soft
- Yellow • Extra Soft
- Black • Processing

STAINLESS STEEL HOUSING
to be soldered or bonded to the frame

STRATEGY POSITIONER
for correct positioning of the cap housing on the frame

INSERTION TOOL FOR CAPS



PARALLELOMETER KEY



PARALLELOMETER KEY PROFILE



SIDE A: For SPHERE positioning
SIDE B: For STEADY positioning

REINFORCEMENT FOR THE SPHERE



- Increased shear force strength
- Prevents rotation of female cap
- Increased lateral stability

OT Strategy from Rhein83 is a vertical micro-sized 1.8 mm castable sphere that is placed distally on abutments for removable partials or utilized in implant bar combination case design. The male component is designed with an additional support strut located under the sphere, increasing strength and preventing rotation of the female cap during paralleling. The optional Steady, when connected to OT Strategy, provides lateral stability without any additional milling.

OT Strategy caps are available for both duplication and fabrication using a stainless-steel housing technique. Rhein83 caps are manufactured from an elastic material that increases the contact zone with the sphere, giving mechanical and friction retention. Caps are color-coded indicating five levels of retention. Tools for paralleling, inserting, and removing caps are available.

CLINIC



LABORATORY



Insert the OT Strategy male into the mandrel and place in position with base of attachment in contact with the stone.



Using the insertion tool, insert the cap.



The entire cap must be covered with a thin layer of wax during the frame wax-up procedure.



Once the casting is complete, proceed to use the cap and the prefabricated **STAINLESS STEEL HOUSING**. The housing can be bonded or laser welded to the frame. In addition, it can also be used for direct chairside procedures.



For best results during the **DUPLICATION TECHNIQUE**, it is suggested to use the **YELLOW** retentive cap.



DUPLICATION TECHNIQUE: USING CASTABLE HOUSING



OT Strategy casting is complete with mandatory lingual milling to accept partial bracing arm.



Yellow retentive cap is placed on the sphere and the model is ready for duplication. Use wax to remove any undercuts.



Model is duplicated and the shape of the cap is reproduced.



Insert the cap into the finished cast partial with the OT Strategy Insertion Tool.



Frame is complete and placed on the model.



The finished prosthesis.

WELDING TECHNIQUE: USING PRE-FABRICATED STAINLESS STEEL HOUSING



Crown and OT Strategy attachment cast. Positioning ring and housing.



Positioning ring on the sphere.



Stainless Steel Housing in position on the attachment.



Wax-up on the duplicated model.



First Option: Stainless Steel Housing welded to the frame.



Second Option: Stainless Steel Housing bonded to frame with anaerobic self-curing resin.



ATTENTION:
Insertion of the cap from the mesial.

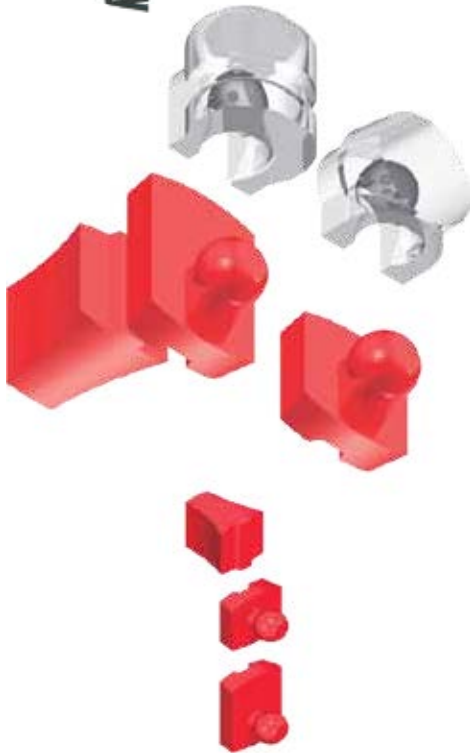

Optional = STEADY

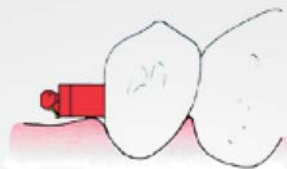

Steady + standard base

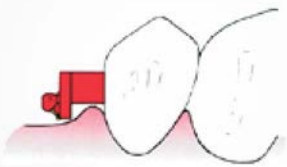

Steady + long base

The castable Steady is an optional conical shaped support intended for use in cases where milling is not performed. Steady can be used with the OT Strategy Standard or Long base.

It is an object in line with the philosophy of the personalization of each single prosthesis and is used with both the OT Strategy bases; Standard or Long and offer various technical solutions.

CLINIC



LABORATORY

TECHNIQUE WITH STANDARD BASE



Lute the two parts together using an adhesive and insert the sphere into the mandrel of the parallelometer.



The Steady can be used with its original height or it can be shortened and modified to accommodate the adjacent tooth and ridge.



Finish the wax-up and give the Steady the necessary shape for duplication in the sphere.



The duplicated model.



The frame wax-up.



The finished casting.

TECHNIQUE WITH LONG BASE



Lute the Steady to the Long base. Be sure to position the two parts according to the resorption of the ridge.



Position the attachment as close to the ridge as possible. Fill the space between the Steady and the ridge with wax.



The finished attachment design. The Steady has been adapted to the contour of the ridge.



Crown and Steady for duplication and retentive cap on the sphere.



Cast framework seated on the model.



Finished prosthesis.

When the **STEADY** base is utilized it provides superior lateral support when milling is not indicated. In the case of free saddles, the **STEADY** base avoids movement in all directions during mastication.

CLINIC **LABORATORY**

OT
strategy

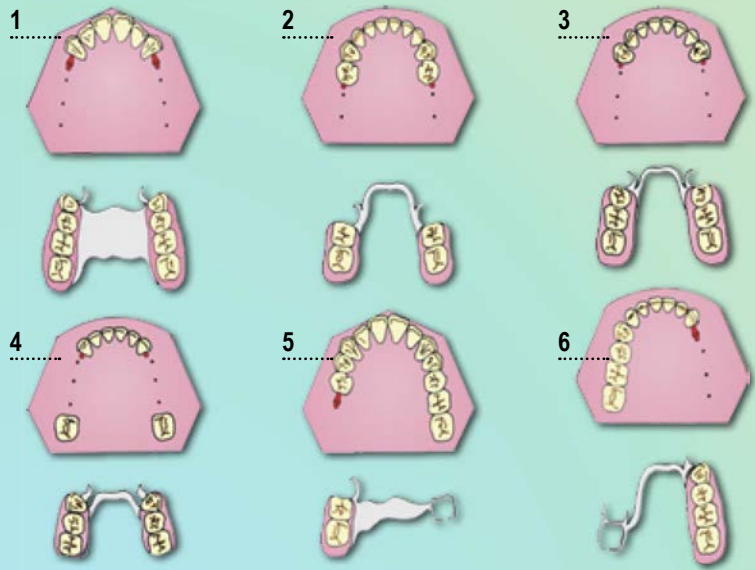

OT
normal
micro
CAP



OT CAP
LOWER
ARCH



OT CAP
UPPER
ARCH

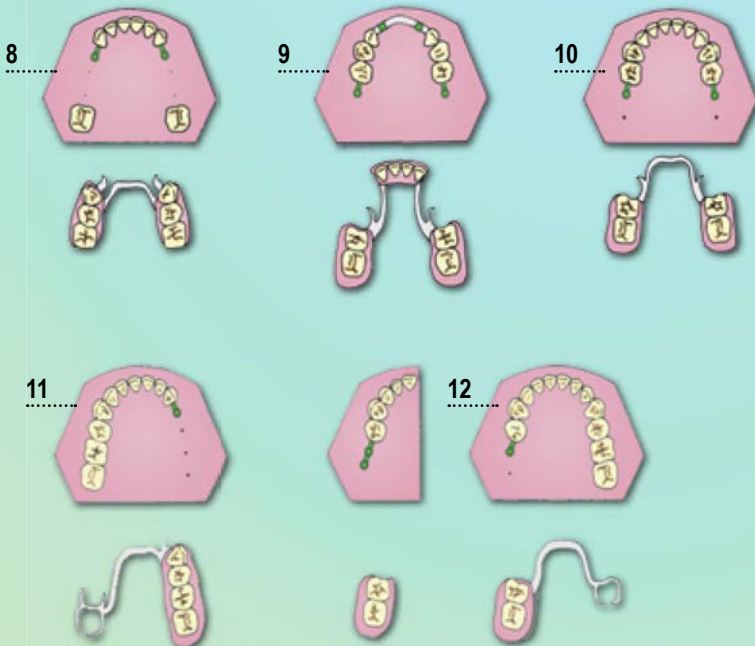
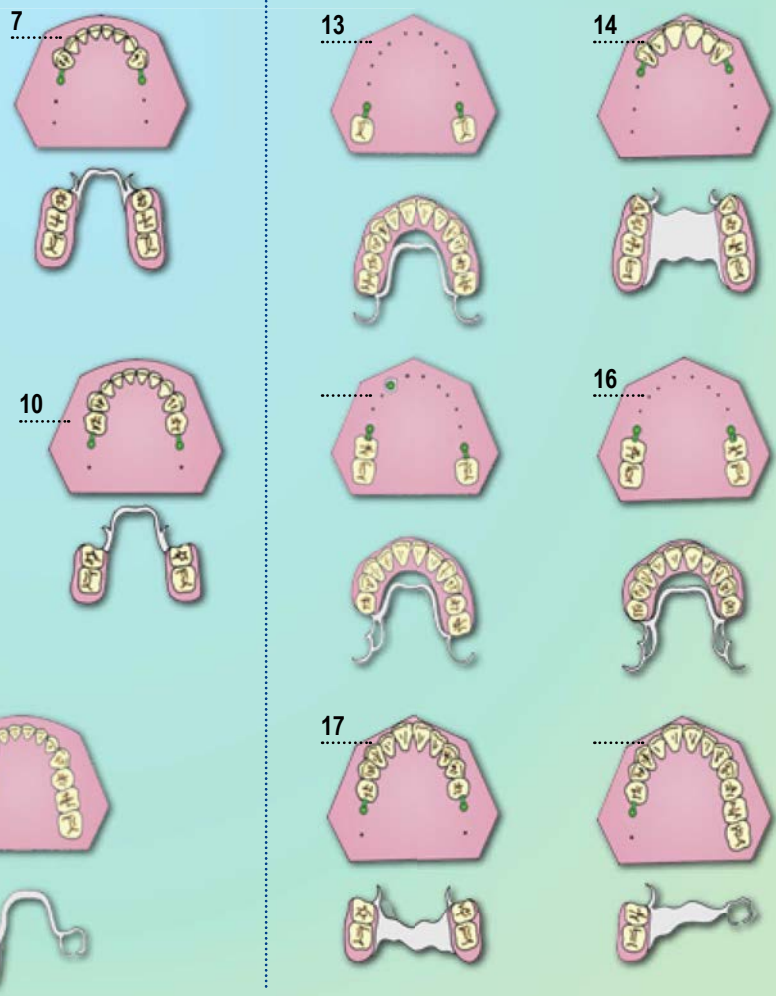

Single Spheres OT CAP



CASTABLE SINGLE SPHERES



NORMAL
Green
Ø 2.5 mm



MICRO
Red
Ø 1.8 mm

STAINLESS STEEL AND TITANIUM HOUSINGS
Normal / Micro size for welding to embody in resin



ELASTIC RETENTIVE CAPS

Normal / Micro



Undersized caps for worn or damaged spheres are also available. They are also compatible with 1.7mm and 2.2mm spheres.
See parts list for item codes and descriptions.

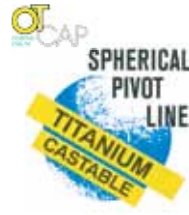

SINGLE SPHERES TITANIUM + TIN FOR WELDING OR BONDING

1600 Vickers Hard

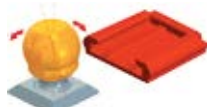

FLEX SPHERE
Ø 2.5 mm



FIXED SPHERE
NORMAL SIZE
Ø 2.5 mm



FIXED SPHERE
MICRO SIZE
Ø 1.8 mm



CASTABLE SLIDING BASE



IMPRESSION COPING
Normal / Micro

PLASTIC PIVOTS

for impression of the root canals



Normal

Micro



PIVOT ANALOGS
Normal / Micro



REMOVAL TOOL FOR RETENTIVE CAPS



PROTECTIVE DISKS



KEYS FOR PARALLELOMETER
Normal/Micro size



MOSSER BURS



INSERTION TOOL
for retentive caps

The design of the sphere with a FLAT head in addition to the spherical inner surface of the elastic cap, permits vertical movement during mastication. Rhein83 female caps are manufactured out of a special nylon material that remains stable and continues to function in the oral cavity over long periods of time.

Clinical data is available showing that stability is obtained with a minimal amount of trauma.

CLINIC



TRANSFER IMPRESSION TECHNIQUE



Put the impression coping on the sphere in the patient's mouth. Different levels of retention are available depending on the color of the cap used.



Impression coping in position, the external profile ensures a stable position in the impression.



Insert analogs into the impression copings and pour the model.



Stone model with analogs in place.

LABORATORY



ATTENTION:

These attachments can be cast with all types of alloys, but it is important to use a metal with a high Vickers rating in order to avoid the risk of wearing the spheres.

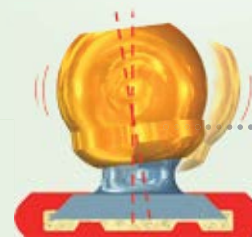

NEW DESIGN

EASY FIT

IMPRESSION OF ROOT CANALS



Prepare the roots.



Apply adhesive to the post.

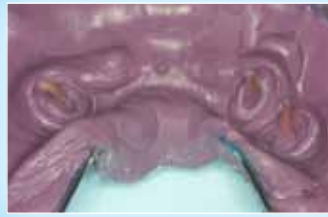

Impression with elastomer.

ATTENTION:

To obtain proper function, it is important to mill the resin with a bur to create a space (highlighted in blue) between the root and the prosthesis.

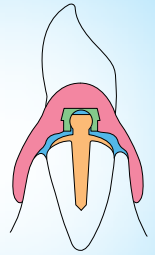

OT CAP - ATTACHING CAPS TO DENTURE



Protective discs on the cast metal spheres.



Fill the space corresponding to the caps with self curing resin. Insert the prosthesis into the final position.



Once the resin has cured, remove the disc and trim the excess material around the cap.



Finished prosthesis.

OT CAP - CASTABLE SINGLE SPHERE TECHNIQUE



Insert the castable plastic post into the prepared root cavity.



Cut the post to the level of the root and remove sphere.



Position the single spheres in parallel with each other.



Cast post and sphere. It is also possible to place the sphere off center in respect to the long axis of the post.

OT CAP - TITANIUM SINGLE SPHERES + TIN TO BE BONDED OR LASER WELDED



Wax-up the root cap. Insert the titanium sphere into sliding base and position on the root cap.



Wax-up with titanium sphere in position. Do not cover the "open" side of the base with wax.



Remove the titanium sphere from the base before attaching sprue.



The finished wax-up with sprue. The root cap and post is ready to be invested.



Using the tool, check the fit of the cast cap by inserting the sphere into the base.



Titanium sphere inserted in the cast root cap base.



Bond the titanium sphere to the base using anaerobic or self curing composite material.



Finished root cap. The sphere is bonded and locked in position.

PIVOTS FOR DIRECT OVERDENTURE



PIVOT FLEX
TITANIUM + TIN
1600 Vickers Hard
"self-parallel" sphere

STAINLESS STEEL AND TITANIUM HOUSINGS
Normal / Micro size for welding to embody in resin



PIVOT BLOCK
TITANIUM

ELASTIC RETENTIVE CAPS
Normal / Micro



SUPER-RESILIENT CAPS



PIVOT FLEX
TITANIUM + TIN
Ø 2.5 mm
3 lengths



PIVOT BLOCK
TITANIUM WITH STATIONARY SPHERE
NORMAL Sphere
Ø 2.5 mm
3 lengths



PIVOT BLOCK
TITANIUM WITH STATIONARY SPHERE
MICRO Sphere
Ø 1.8 mm
3 lengths



COPING COVER RING FOR OVERCASTING
Steel Alloy

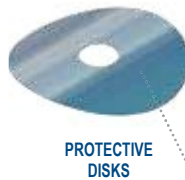

MOOSER BURS

SPRING

PROTECTIVE DISKS

The Pivot Flex line of titanium posts was developed as an **economical** solution for direct "in root" supported overdentures. The self-aligning Pivot Flex post features a rotating ball with a 2.5 mm diameter and is indicated for divergent roots. When the posts are used with directional rings to align retentive caps before the resin curing stage, the insertion of the denture is easy and trauma-free.

The Pivot Block line of milled titanium posts has a stationary ball and can be used for a temporary or as a permanent solution. The Pivot Block titanium posts are available in 2.5 mm and 1.8 mm sphere diameters. The Rhein83 elastic caps ensure optimal retention and function while minimizing wear.

There are five levels of retentive caps, including extra resilient caps for precarious root situations. The levels of retention are identified by different colored caps.

CLINIC

DIRECTIONAL RINGS



The **WHITE** directional ring is used for parallel roots. **GREEN** and **RED** directional rings are used when angle correction is indicated. Directional rings must be used to position the retentive caps in parallel and in the same horizontal plane to correct divergence.

PIVOT FLEX AND PIVOT BLOCK



COPING COVER

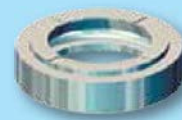

The Coping Cover is used to construct a cast metal cap preventing additional exposure to the remaining root which has been subject to decay, by creating a seal over the remaining exposed dentition.

LABORATORY

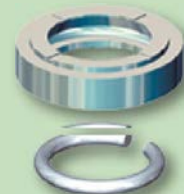

DIRECTIONAL RINGS - FOR FIXED AND ROTATING SPHERES



Pivot Flex posts in divergent roots.



Nylon caps **without** directional rings. Caps are not supported in the same horizontal plane.



Nylon caps **with** directional rings. Caps are now supported in the same horizontal plane.

PIVOT BLOCK - FOR TEMPORARY OR PERMANENT ECONOMICAL SOLUTIONS



Pivot Block cemented with oxyphosphate cement for a temporary solution.



To remove the post from the root, grasp the sphere with the pliers and rotate carefully in both directions.



Due to the conical shape and smooth surface, the post is removed easily.



For permanent solutions, create notches in the post and roughen the surface before cementation.

PIVOT FLEX AND PIVOT BLOCK SYSTEM - COPING COVER FOR OVERCASTING

CLINICAL PHASE 1: Impression



Clinical Phase 1: Preparation

Prepare the occlusal portion of the root until the collar of the post is fully exposed and carefully clean around it.



Clinical Phase 1: Impression

When taking the impression, include the post and the entire occlusal surface of the root which is necessary to reproduce the cast coping cover.

CLINICAL PHASE 2: Fixing



Clinical Phase 2: Try-In

Place cast coping cover on the root assuring acceptable fit and proceed with final cementation.



Clinical Phase 2: Cementation

Bond the coping cover with cement. Once the cement is cured, the locking spring becomes a unique body with the post.

WAX-UP AND CAST



For best results, use a synthetic or "non-chipping" die stone. It is important that the circular part of the post be reproduced accurately.



Position the coping cover on the model without the locking spring.



Complete wax-up and cast.



Polish the coping cover and insert the locking spring.

Castable Bar Cap Housings



CLASSIC + CONNECTOR



CLASSIC BARS
NORMAL - Green + Yellow
MICRO - Red + Yellow



CONNECTOR
Universal castable bar for joining the OT BOX housings



SPECIAL + CONNECTOR



ELASTIC RETENTIVE CAPS Normal / Micro size

- Clear • Standard
- Pink • Soft
- Yellow • Extra Soft
- Green • Elastic
- Black • Processing

EXTRA-RESILIENT CAPS

- Gold • Slightly Elastic
- Silver • Elastic and Gummy

SPECIAL BARS NORMAL - Green MICRO - Red



ANALOGS
Normal / Micro

CLINIC



Cast reinforcement wax-up on the master model without duplication.

LABORATORY

OVERSIZED CASTABLE HOUSING for repositioning the caps directly in the patient's mouth



NORMAL + CONNECTOR



MICRO + CONNECTOR



The OT Box Large casting compensates for the distance between the cap and the housing. It is manufactured to reposition the cap chairside into the frame.



A fracture is likely at the point where the overdenture attachments are inserted in a prosthesis fabricated entirely of resin. With a cast superstructure reinforcement, the denture will be less likely to fracture. Fast and simple, the OT Box bar components are used to fabricate the superstructure directly on the master model, eliminating duplication and saving time. A non-precious or chrome cobalt alloy is recommended for best results.

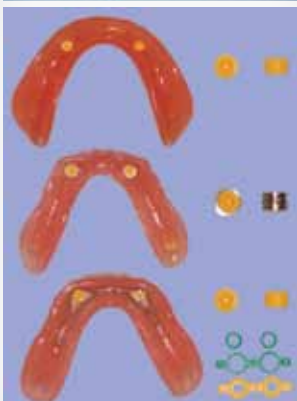

It is recommended that all nylon caps are inserted into a stainless steel housing or cast reinforced frame. The stainless steel housing offers a considerable advantage when the cap has to be removed and replaced for routine maintenance or repositioned. Adjustments or repairs can be performed chairside quickly and easily.

Option 1: OT CAP
OT Cap cured directly into the prosthesis.

Option 2: OT Cap + Stainless Steel Housing
OT Cap with housing cured directly into the prosthesis or bonded into frame.

Option 3: OT Cap + OT Box
OT Cap inserted into OT Box cast reinforced frame.

LABORATORY REQUIREMENTS FOR THE MASTER MODEL

When a new denture is being fabricated utilizing existing spheres, the dentist must provide the laboratory with an impression using the **YELLOW CAP**. The laboratory will place the analog into the cap and pour the stone model.



CAST REINFORCEMENT IN ACRYLIC DENTURES without duplication of the model

IMPRESSION WITH POSTS FIXED IN THE MOUTH



Titanium posts cemented into the root.



YELLOW CAPS in position. The impression is ready to be taken.



For best results, use a "stiff" bodied impression material to ensure accurate positioning of the cap. The laboratory will insert the analog for the sphere.



The stone model with the analog of the sphere.



Another Example: The stone model with cast root coping and retentive caps in position.

OT BOX CLASSIC + CONNECTOR

DIRECT WAX-UP ON THE MASTER MODEL



OT Box Classic. Glue the two OT Box bars together.



Separate the housing from the OT Box bar connector.



Apply a layer of wax on the ridge. Create three holes in contact with the stone model. Place the positioning rings over the spheres. Be sure to place the ring with the "flared" end towards the coping.



Position the OT Box Classic or Special housings over the rings. Complete the reinforcement using the connectors and join the pieces together with self-polymerising resin.

"ONE-PIECE" MONO BAR
OT BOX SPECIAL is a "one-piece" mono bar. Separate the bar and use only the section needed.



Finished wax-up with sprue; ready to be invested.



Finished casting with black retentive caps in housing.



Complete prosthesis with cast reinforcement.



For additional reinforcement...with the silicon mask in position, insert a wax pin to support each tooth before casting.



ROOT ATTACHMENT TITANIUM + TiN



CLINIC



PROSTHESIS WITH REINFORCEMENT IN CAST METAL

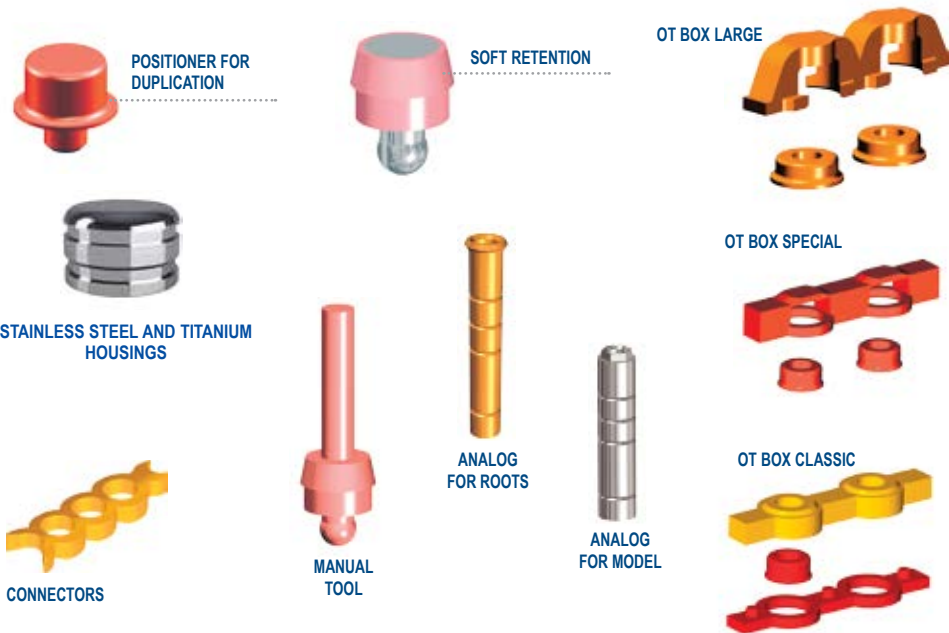

LABORATORY



OT REVERSE 3 is a root supported direct pivot attachment system which provides retention and stability for full dentures. The "split" male portion of the attachment is manufactured from titanium that is embedded into a soft nylon material. The female pivots have a unique shape that is designed to fit most remaining root structures. **OT REVERSE 3** is successful even with minimal bone support of the remaining dentition. The system is cost effective with simple laboratory and chairside procedures.

ROOT PREPARATION AND IMPRESSION



Use the diamond sizing bur to prepare the root for the attachment. Using the hand tool, insert the plastic pivot and apply cement.



Pivots cemented into the roots. Insert the male transfer coping into the pivot and take the impression. For best results, use a stiff bodied impression material.



The laboratory will place the analog and pour the stone model.



The stone model with the OT REVERSE 3 analog in position.

CHAIRSIDE PROCEDURES



If you are using the plastic retentive male, remove the stem. Caution: If the prosthesis is inserted incorrectly, it could bend and it will not fit into the female housing.



Place the attachment with self-curing resin. It is important to always use the protective disk around the perimeter of the attachment.



When OT Box Large is used, enlarge the space using a carbide bur to reduce interference with the male.



Fill the spaces with self-curing resin. Insert the prosthesis into the patient's mouth and have them bite down until the resin has cured.



Remove the prosthesis and trim the excess resin.

FABRICATION OF FRAME FOR DIRECT ROOTS OR IMPLANTS



OT BOX CLASSIC
Glue the two OT Box sections together.



OT BOX CLASSIC
Separate the two housings and trim any excess material. Use only the part that is needed.



OT BOX SPECIAL
Separate the two housings and use only the part that is needed.



OT BOX LARGE
Separate the two housings and use only the part that is needed.



OT REVERSE 3
Stone model with analogs, denture setup and silicon guide.



Insert positioners in the analogs. Apply wax on the gingival crest. Make holes in the wax in contact with the stone. Be sure to use stone separator.



Position the sectioned OT Box housing of choice. Complete the reinforcement by using the castable connectors.



Join all of the components with self-curing resin. With the silicon mask in place, insert a wax pin for each tooth for additional support.



Remove the OT Box frame from model. Fill in any voids with wax.



White or pink opaque can be used to block out the metal frame.



Sandblasted Cast Reinforcement



The finished prosthesis. Attachments are inserted into the cast housings.

The finished prosthesis on the stone model.



RECONSTRUCTIVE SPHERES

Titanium + TiN coating

Concave Reconstructive Sphere

MULTIUSE

TITANIUM +
TIN COATING

more than 1600 Vickers

Available for any
implant system on
the market!



CONCAVE SPHERE Sizes:

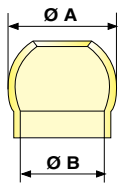

CONCAVE SPHERE

Ø A	Ø B
2,5 mm	1,9 mm
2,2 mm	1,55 mm
1,8 mm	1,4 mm

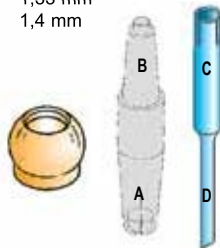

- A - Sphere support
- B - Sphere holder
- C - Strip holder
- D - Spatula for applying cement to the inside of the sphere.

For existing cases with worn spherical attachments which no longer provide adequate retention, the **DR8 UNDERSIZED CAP** can be used in the early stages of wear of the male component. This elastic cap offers an inner dimension of 1.7 mm and 2.2 mm which is smaller than Rhein83 normal and micro size caps and can be used with standard Rhein83 stainless steel housings.

When ball attachments show excessive wear, the **CONCAVE RECONSTRUCTIVE SPHERES** are recommended as the best long term restorative option. The **CONCAVE RECONSTRUCTIVE SPHERES** restore the worn male to it's original size of 1.8 mm, 2.2 mm or 2.5 mm diameter. **CONCAVE RECONSTRUCTIVE SPHERES** are manufactured with a Titanium Nitrite coating and are rated over 1600 Vickers hard.

The chairside procedure for using the reconstructive spheres is fast, easy and provides an economical alternative to replacing the old restoration.



Aqua caps are shown

DR8 Undersized Caps are available in 3 levels of retention for normal and 2 levels of retention for the micro size.

CLINIC

Dental attachments, like most other mechanisms, are subject to wear and tear. Rhein83 produces spheres for restoring worn ball attachments which restore and stabilize the prosthesis in a single appointment. Reconstructive spheres are bonded over the worn ball restoring the attachment to it's original size.

CONCAVE RECONSTRUCTIVE SPHERE RESTORING A WORN SPHERE



Insert the concave sphere into side A of the plastic tool. Fit over the worn out sphere in the mouth.



If the concave sphere does not fit passively, use a cylindrical bur (diamond or carbide) to slightly reduce the diameter. Check the fit again and repeat as needed.



Check the position of the concave sphere on the worn sphere and finish by cleaning the two parts.



Additional surface can be removed by using side C of the tool. Insert a diamond strip into the notches, place the tool over the sphere and turn the manually.



Place a small amount of two-part self curing "metal to metal" resin inside the sphere.



Place the concave sphere over the worn sphere and wait for the resin to cure.



Once the resin has cured, remove any excess material.



The completed repair. The cap can be repositioned if necessary.

Rhein83 offers two types of reconstructive spheres; A solid sphere and a concave sphere. Both types are titanium nitrate coated with a Vickers hardness rated over 1600. The Concave Reconstructive Spheres are available in 1.8 mm, 2.2 mm and 2.5 mm ball diameter. The Solid Reconstructive Spheres are only available with a 1.8 mm ball diameter. The Concave Sphere is used for restoring worn ball attachments and the Solid Sphere is used for restoring ERA® and CEKA® type attachments.

SOLID RECONSTRUCTIVE SPHERE RESTORING A WORN RING ATTACHMENT



The worn-out female ring attachment.



Apply a small amount of two-part self-curing "metal to metal" resin on the bottom of the sphere. Insert the sphere into the attachment using the tool. Wait for the resin to cure.



The female attachment was converted into a male OT Cap Micro directly in the patient's mouth.

SOLID RECONSTRUCTIVE SPHERE RESTORING A WORN OVERDENTURE BAR



Create a hole in the wall of the bar using a 1.6 mm ball drill.



Apply a two part composite to the shank of the sphere. Using the tool, insert the sphere into the hole. Wait for the composite to cure.



The sphere is firmly cemented in place. The OT Strategy Cap can now be used in the prosthesis resulting in stability and retention.

SOLID RECONSTRUCTIVE SPHERE RECOVERY OF TITANIUM ABUTMENTS



A case with unknown titanium abutments. Worn openings are present on top of the fixtures.



Solid Reconstructive Spheres are placed into the openings. A two-part self-curing "metal to metal" resin is applied.



Retentive caps are positioned into the existing denture. The denture is now stable and secure.

Solid Reconstructive Sphere

MULTIUSE

SOLID
"RECONSTRUCTIVE"
TITANIUM +
TIN COATING
rated over 1600 Vickers

TO REBUILD ANY
"RING" TYPE ATTACHMENT
SUCH AS: ERA® AND CEKA®



TOOL
to hold the sphere

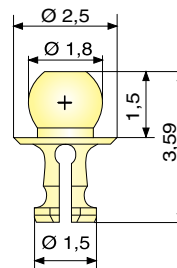

SOLID SPHERE
Micro Ø 1.8 mm



Dual Cure "Metal to Metal" Resin
material recommended for the following products:

- OT CAP TECNOC
- CONCAVE SPHERE
- SOLID SPHERE
- COPING COVER

The **SOLID RECONSTRUCTIVE SPHERES** can be bonded to the inside of hollow attachments or those with a female ring such as ERA® and CEKA®

Reconstructive Spheres can be used to repair various attachments available on the market. These attachments can be found in many types of prosthesis including overdentures, implants, roots and frameworks. If worn or broken, they cannot be repaired easily.

The **SOLID RECONSTRUCTIVE SPHERES** offer a fast and easy cost effective alternative, transforming a female ring attachment into a male Micro **OT CAP** attachment. This repair can be completed chairside in a single appointment.

BAR AND CAST OVERSTRUCTURE on the master model without duplication

OT BAR MULTIUSE + CONNECTOR

A



CASTABLE BAR
version **A**



GINGIVAL
CONNECTOR
OPTIONAL

B



CASTABLE BAR
version **B**



CONNECTOR
Universal castable bar for joining the CASTABLE
BOX housings



POSITIONING
CLIP A



POSITIONING
CLIP B

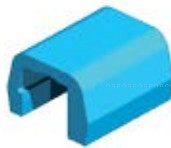

CASTABLE BOX



RETENTIVE
YELLOW CLIP
MEDIUM RETENTION



RETENTIVE
PINK CLIP
SOFT RETENTION

KEY FOR
PARALLELOMETER



TOOL FOR
INSERTING CLIP



The **OT BAR MULTIUSE** is designed with a 4 point retentive system. This unique system provides superior retention and can be utilized for both rigid and resilient functionality. With its innovative two-sided design (Side A is rounded and Side B side is flat), depending on the indication, either side can be used. If a resilient solution is required the bar is positioned with the flat side facing up or if a rigid solution is required then the bar is positioned with the round side facing up. **OT BAR MULTIUSE** can also be used as a connecting bar between canines in the anterior region.

OT BAR MULTIUSE and the cast housing are fabricated directly on the master model saving time by eliminating the need for duplication.

CLINIC

LABORATORY

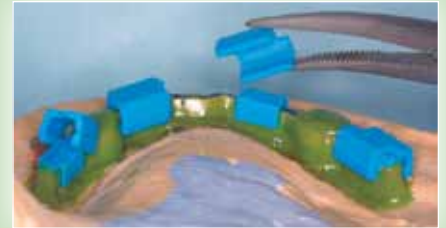

Castable Bar
Side **A**



Castable Box



Positioning
CLIP **A**



Yellow Clip
Medium Retention



Pink Clip
Soft Retention



SIDE A

The rigid bar is used as a "connection" between two stable teeth where a "back and forth" motion is required. The bar can also be used in scenarios involving multiple abutments where the prosthesis is supported by a thin layer of soft tissue.



Castable Bar
Side **B**



Castable box



Positioning
CLIP **B**



Yellow Clip
Medium Retention



Pink Clip
Soft Retention

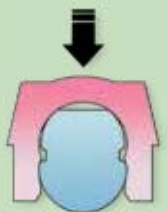

SIDE B

The resilient bar is most often used in scenarios involving multiple abutments where the prosthesis is supported by a "normal" layer of soft tissue.

CASTABLE BAR IN TWO VERSIONS

RESILIENT - RIGID



FABRICATION OF THE SUPERSTRUCTURE ON THE MASTER MODEL WITHOUT DUPLICATION

SIDE A - RIGID

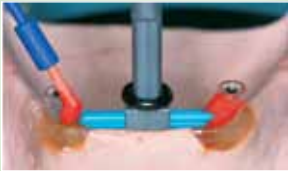

Mount the bar using Side A of the mandrel. Using resin or wax, complete the model.



The finished casting. Be careful not to wear out the retentive surfaces when polishing.



Block out any undercuts using wax and place Positioning Clips A on the bar.



To isolate, apply a small piece of tape (ex: teflon, Scotch) on the Positioning Clips A and on the cast bar. Insert the castable box housings.



To prevent resin from adhering to the bar, place a small piece of adhesive tape (ex: teflon, Scotch tape) over the bar. Use self-curing resin to connect the castable boxes.



Complete the model using wax and add castable connectors for extra reinforcement of acrylic. Sprue the model and cast.



The completed casting with retentive clips snapped in place.



The finished denture with cast reinforcement and retentive clips in place.

SIDE B - RESILIENT



Mount the bar using Side B of the mandrel. Using resin or wax, complete the model.



The completed casting. Use caution when polishing the surface. Be sure not to wear out the retentive undercuts.

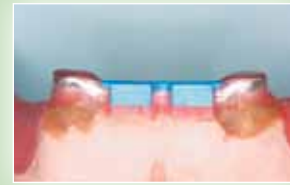

Use wax to remove all undercuts. Apply a thin layer of wax on the top of the bar to create a cushion. Insert Positioning Clips B.



To isolate, apply a small piece of tape (ex: teflon, Scotch) on the Positioning Clips B and on the cast bar. Insert the castable box housings.



To prevent resin from adhering to the bar, place a small piece of adhesive tape (ex: teflon, Scotch tape) over the bar. Use self-curing resin to connect the castable boxes.



Complete the model using wax and add castable connectors for extra reinforcement of acrylic. Sprue the model and cast.



The completed casting with retentive clips snapped in place.



The finished denture with cast reinforcement and retentive clips in place.

OT VERTICAL Attachment

Castable
Twin Cylinder
Attachment
with centering and
balancing pin



CASTABLE STEADY FOR VERTICAL

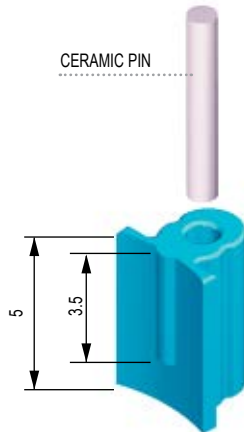

CERAMIC PIN

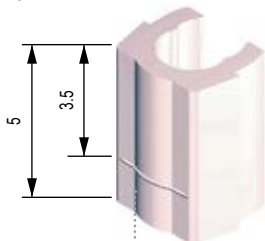

WHITE CLIP
Standard Retention



GREEN CLIP
Soft Retention

INSERTION TOOL FOR CLIPS



NEW STEADY

The cast metal guide pin is necessary to center, connect and balance the prosthesis during the final insertion. When milling or "cross arch" stabilization are not possible, the guide pin along with the **NEW STEADY** will provide lateral stability to the prosthesis. This ensures a longer life for the retentive clips. The vertical height of the attachment can be adjusted by reducing both male and female parts from the original length of 5 mm down to 3.5 mm according to the pre-marked notches. Reducing the vertical height creates no difference in functionality. Removal and replacement of clips can be easily performed by the Dentist chairside.

LABORATORY

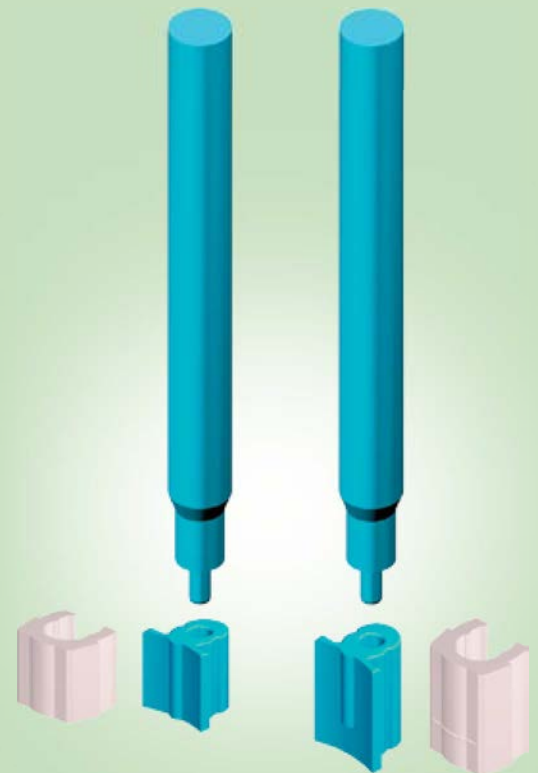

ATTENTION

When shortening the **OT VERTICAL** attachment, it is suggested that the clips not be reduced more than 3.5 mm to prevent excessive wear or failure. The limit is indicated by a notch on both male attachments and clips.

REPLACEMENT OF RETENTIVE CAPS

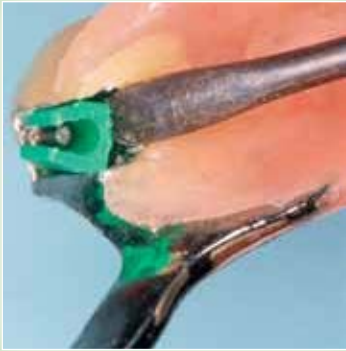

Remove the clip using a flat round instrument.

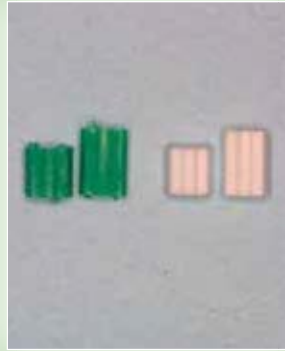

Once it has been removed, compare the height of the old clip to the height of the new clip.



If the clip needs to be reduced, use a rotary instrument to shorten according to the notch on the back.



Insert the new clip using the OT VERTICAL insertion tool.



The attachment and the clip can be mounted with its original height (5 mm) or shortened (3.5 mm) by filing the side opposite the hole.



Once the assembly and the wax model have been completed, insert the ceramic cylinder into the hole of the attachment and cast.



After the attachment has been connected with wax, insert the pin into the hole on the top of the attachment. Rotate the pin until a proper fit is obtained and it is easily removed.



Sandblast the casting. Use a round bur or appropriate acid to remove any ceramic material that may be present in the hole.



Before duplicating the model, remove the tip of the plastic pin that is located on the end of the parallelometer key mandrel from the rest of the shank.



Insert the pin into the hole of the attachment and pour the duplicating material (silicone or gelatin).



The castable plastic pin in the duplicated model. The pin can either be removed or remain in the model.



Complete the wax-up of the frame and proceed with casting.



The cast framework.



The finished framework. Insert the retention clips using the OT VERTICAL insertion tool.



The finished framework on the model. Even without milling, the cast pin provides stability to the prosthesis.



Lowering the male portion of the attachment increases the gingival load and reduces the vertical stress on the supporting teeth.

COMBINED RETENTION ATTACHMENT

For Multi-Functional Prosthetics

OT UNILATERAL



RETENTIVE CAPS OT CAP Micro

- Clear • Standard
- Pink • Soft
- Yellow • Extra Soft
- Green • Elastic
- Black • Processing

RETENTIVE CAPS OT Strategy for duplication

- Clear • Standard
- Pink • Soft
- Yellow • Extra Soft
- Black • Processing

TOOLS



The **OT UNILATERAL** castable attachment from **Rhein83** is specifically intended for unilateral, bilateral or implant bar applications without additional support from milled bracing arms.

OT UNILATERAL's exclusive design features a two-in-one combination of 1.8 mm horizontal and vertical spheres utilizing **OT CAP** and **OT STRATEGY** micro size female caps. The male section of the attachment is engineered with a vertical strut which extends through the base of the attachment providing exceptional lateral stability and distal support to the prosthesis.

The Uni-Box female component is a one piece castable housing that covers the entire male section, adding superior strength to the acrylic.

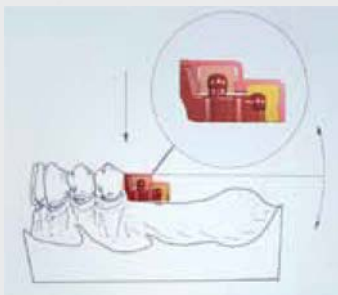

LABORATORY



EXCLUSIVE FEATURE

2-IN-1 DESIGN - A COMBINATION OF HORIZONTAL AND VERTICAL MICRO SPHERES ARE USED WITH THE **OT CAP** AND **OT STRATEGY** ATTACHMENT SYSTEMS



MULTIPLE BENEFITS

BECAUSE OF IT'S UNIQUE DESIGN, **OT UNILATERAL** PROVIDES:

- * LATERAL STABILITY
- * NO MILLING REQUIRED
- * SUPERIOR RETENTION
- * CONTROLLED RESILIENCY
- * OVERALL FUNCTIONALITY
- * ECONOMICAL SOLUTIONS

LABORATORY PROCEDURE - SUPERSTRUCTURE SETUP TECHNIQUE



Position the OT UNILATERAL using the OT CAP paralleling mandrel.

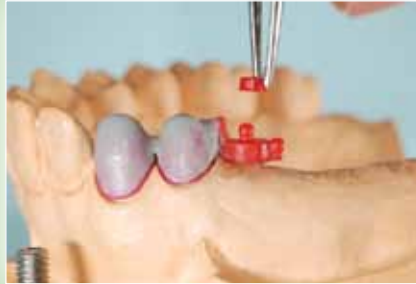

Place the positioning ring over the OT CAP Micro sphere.



With the positioning ring on the sphere, place the Uni-Box castable housing over the OT UNILATERAL attachment. The positioning ring assures stability for the female cap.



To reinforce the structure, use a pattern resin to join the Uni-Box to the connector.



Before spruing and investing, be sure to remove the positioning ring from the OT CAP sphere.



Invest OT UNILATERAL and Uni-Box in one step into casting ring. For best results, use an alloy with 240 Vickers.



Cast crowns and super-structure. Sandblast the casting, be careful not to "over sandblast" the spheres. Insert black processing caps and proceed.



In order to provide good stability, wax-up the "saddle plate" so that it adapts to the ridge as much as possible.



◀ The completed prostheses with final retentive caps in place.

OT Lock

LOCKING PIN TITANIUM

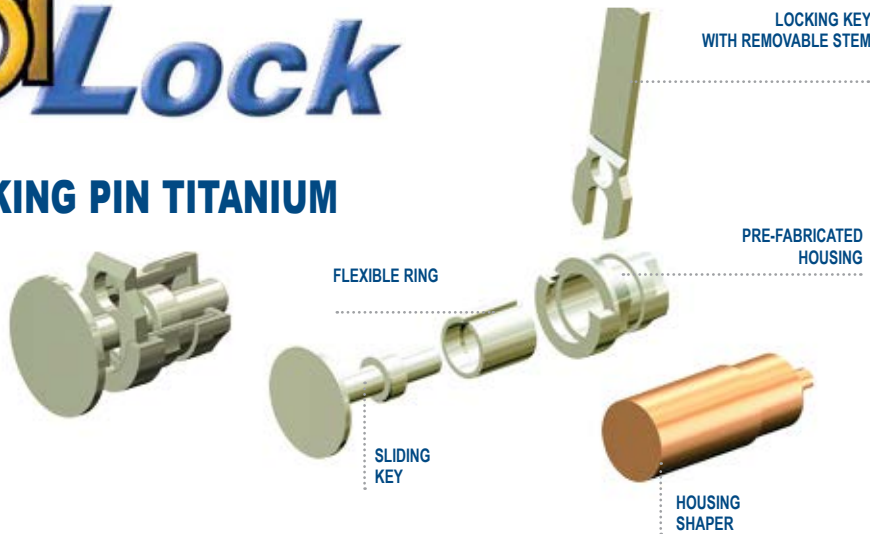

CASTABLE LOCKING PIN

HOUSING OBTAINED WITH A CERAMIC PIN

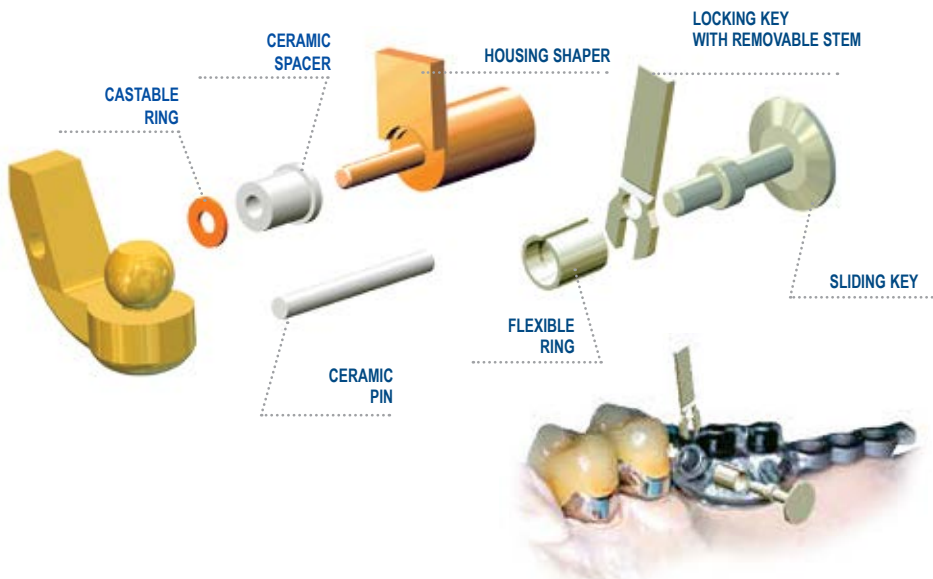

ADJUSTABLE TITANIUM LOCKING PIN

SPACER RING SYSTEM TO POSITION THE KEY TO THE DESIRED SHAPE

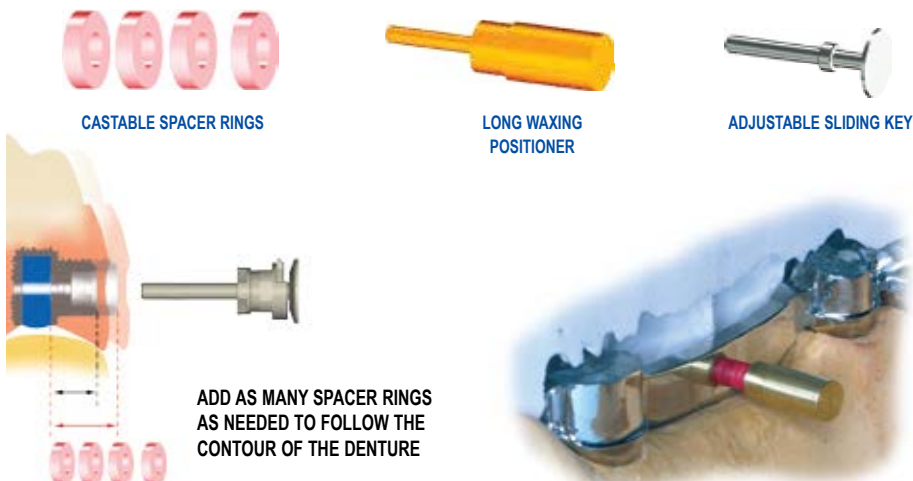

CLINIC

OPTIONAL
for the patient
CONICAL GUIDE AND UNLOCKING TOOL



UNLOCK THE PROSTHESIS BY INSERTING THE UNLOCKING TOOL INTO THE CONICAL GUIDE.

LABORATORY

LOCKING KEY IN POSITION WITHOUT SPACER RINGS

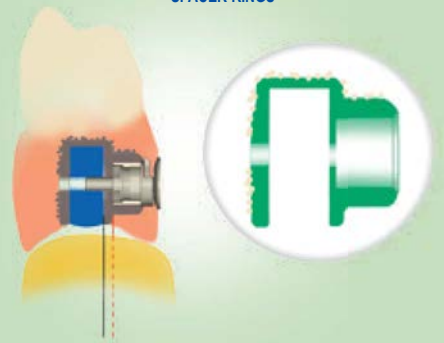

LOCKING KEY POSITIONED USING SPACER RINGS TO FOLLOW THE CONTOUR OF THE DENTURE

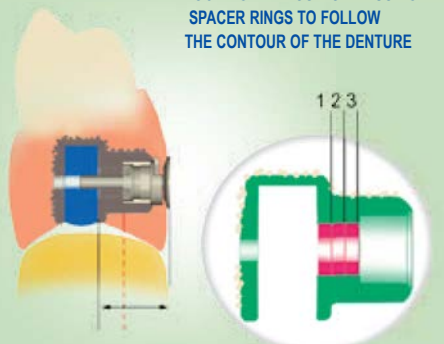

LABORATORY

OT Lock TITANIUM



Model the bar in resin and drill a 0.8 mm hole in the most ideal position.



Insert the ceramic pin through the hole.



The finished and polished bar.



Insert the housing shaper into the hole and lock it in place using resin. Be sure not to go past the "STOP" when applying resin



Using resin, complete the model of the superstructure up to the "STOP". Remove the housing shaper and cast.



Insert the pre-fabricated housing and bond.



Place the titanium housing into the denture. Insert the LOCKING PIN body and then lock it in place with the LOCKING KEY. Secure it in place with resin and break off the extension of the key.



Finished prosthesis. Determine whether or not to use the EXTRACTOR KEY

OT Lock CASTABLE



Place the ceramic spacer and the castable ring onto the housing shaper.



Insert the housing into the hole in the bar and secure with resin.



Model the structure with resin. Cover the ceramic shaper and the underlying part of the housing shaper.



IMPORTANT: Do not cover the square upper portion of the housing shaper with resin.



Remove the housing shaper from the resin structure.



Insert the ceramic pin into the hole and cast.



Remove the ceramic pin and sandblast the casting.



Clean the internal chamber. Insert the sliding key into the flexible ring.



Insert the OT Lock assembly into the housing.



Insert the locking key into the retention guide and secure it with composite



Break off the exposed portion of the locking key.



The completed prosthesis with integrated OT Lock.

IMPLANT OVERDENTURE ATTACHMENTS - SPHERO FLEX - SPHERO BLOCK

Rotating & Stationary Ball Abutments For Divergence Correction

TITANIUM + TIN COATING PROVIDES 1600 VICKERS HARDNESS

SPHERO FLEX

"SELF-PARALLELING" SPHERES

2.5 mm



SPHERO BLOCK

STATIONARY BALL ABUTMENT

2.5 mm



OT SPECIAL BOX



NORMAL - Green
MICRO - Red



IMPRESSION COPING
Normal / Micro size



DIRECTIONAL RINGS

(REQUIRED FOR LAB AND CLINICAL PROCEDURES)

News



STAINLESS STEEL AND TITANIUM HOUSINGS
Normal / Micro resin to be laser welded

ELASTIC RETENTIVE CAPS
Normal / Micro



Clear • Standard



Pink • Soft



Yellow • Extra Soft



Green • Elastic



Black • Processing



TITAN CAP
Normal / Micro



Gold • Elastic



Silver • Elastic Gummy



OT CLASSIC BOX



BARS
NORMAL SIZE = Green + Yellow
MICRO SIZE = Red + Yellow



ANALOGS

SPHERO FLEX / SPHERO BLOCK

UNIVERSAL KEY + HANDPIECE CONNECTOR



PROTECTIVE DISK



CONNECTOR For OT Box



The Sphero Flex implant overdenture attachment is compatible with all implant systems currently on the market. Featuring a rotating ball with a diameter of 2.5 mm that is flexible to 7.5° in all directions. When used with a 14° directional ring, Sphero Flex corrects divergence up to 43° between two implants. Sphero Flex creates a passive path of insertion which reduces trauma to the implant.

Sphero Block is a "one-piece" milled stationary ball implant attachment. It is available in 2.5 mm and 1.8 mm diameters. Sphero Block provides exceptional stability and corrects divergence up to 28° between 2 implants. Sphero Block implant attachments are compatible with all implant systems currently on the market.

Sphero Flex and Sphero Block are manufactured with cuff heights ranging from 1 mm to 7 mm.

NOTE: The Sphero Flex and Sphero Block attachments are available for all platform diameters.

CLINIC



Cross-Section of Sphero Flex

WITHOUT DIRECTIONAL RING



Caps are "over-rotated" and not in the same horizontal plane

Directional Rings eliminate "over-rotation." Caps are aligned in the same horizontal plane.



WITH DIRECTIONAL RING

LABORATORY



3 EASY STEPS

1. Place directional rings (green and red are shown here) over the spheres establishing a level plane.
2. OT BOX positioners are placed over spheres to support box housing during framework fabrication.
3. After gluing the 2 OT BOX parts, cut and use the necessary pieces for the housing.

OVERDENTURE ATTACHMENTS SPHERO FLEX - SPHERO BLOCK

Rotating & Stationary Ball Abutments For Divergence Correction

CHAIRSIDE PROCEDURE FOR POSITIONING THE CAPS



Screw the attachment into the implant. For best results, unscrew and tighten attachment. Perform this operation 3-4 times.



Select the appropriate directional rings and place them over the spheres. Be sure that the ring is aligned with the hex and seated properly on the platform.



Once the directional rings have been positioned, it is advisable to remove the retentive caps and place a protective disk over the spheres. Replace the retentive caps in original position when finished.



Try the prosthesis in the mouth. Check to see if there is enough space for the retentive caps. Fill the holes with self-curing resin and position the prosthesis over the caps and spheres in the patient's mouth.



Once the resin has hardened, remove the prosthesis. Remove the protective disk along with any excess resin.



Finished prosthesis

TAKING IMPRESSION TRANSFER



Place the directional ring over the sphere with the flat side facing down. Place the impression coping over the sphere.



Rotate the directional rings to achieve a common axis parallel to the occlusal plane and take the impression.



Remove impression. Directional rings must be removed from the impression and spheres.



Place the analogs into the impression copings and send to the laboratory for model fabrication.

OT BOX CLASSIC NORMAL - CAST REINFORCED ACRYLIC PROSTHESIS USING DIRECTIONAL RINGS



Place directional rings over the spheres. OT BOX is placed over the directional rings, ensuring that the horizontal plane is level. Connect with resin.



The constructed OT BOX substructure with reinforced wax pins. Sprued and ready for casting.



The cast substructure on the model. The metal reinforcement pins for each tooth are positioned according to the silicone mask.



Finished prosthesis with caps inserted in the cast OT BOX housings.



Screw the abutment into the analog. Be sure to use the abutment with the proper cuff height.



Directional rings are placed over the abutments and must be fully seated on the platform. Rotate rings until they are parallel in the same horizontal plane.



The nylon caps are inserted into the stainless steel housings and placed on top of the directional rings. Verify that the caps are still in the same horizontal plane.



The finished prosthesis with stainless steel housings and retentive caps in final position.

IMPLANT OVERDENTURE ATTACHMENTS

Components and Accessories

DIRECTIONAL RINGS

for angle correction

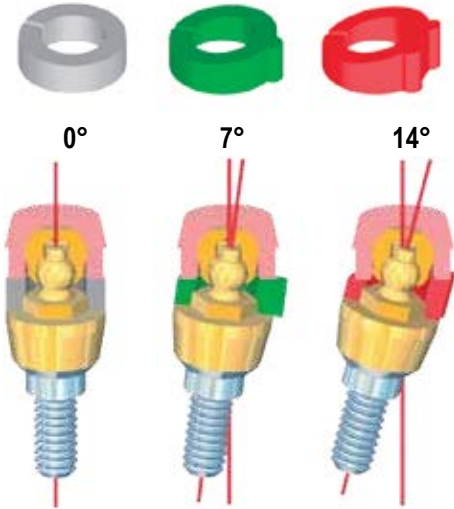

To establish a passive path of insertion, directional rings must be used to position the retentive caps in parallel and in the same horizontal plane to correct divergence.

The **WHITE** directional ring is used for parallel abutments. **GREEN** and **RED** directional rings are used when angle correction is indicated.



SPHERO FLEX

SPHERO BLOCK

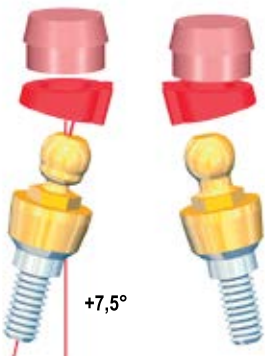

UNIVERSAL "ANTI-UNSCREWING" SYSTEM WITH ELASTIC INSERT

Recommended for Sphero Flex, Sphero Block and OT Equator attachments with a cuff height over 5 mm. This system can also be used for single screws. (Core Vent, Branemark, Pitt Easy, Bona Fit)

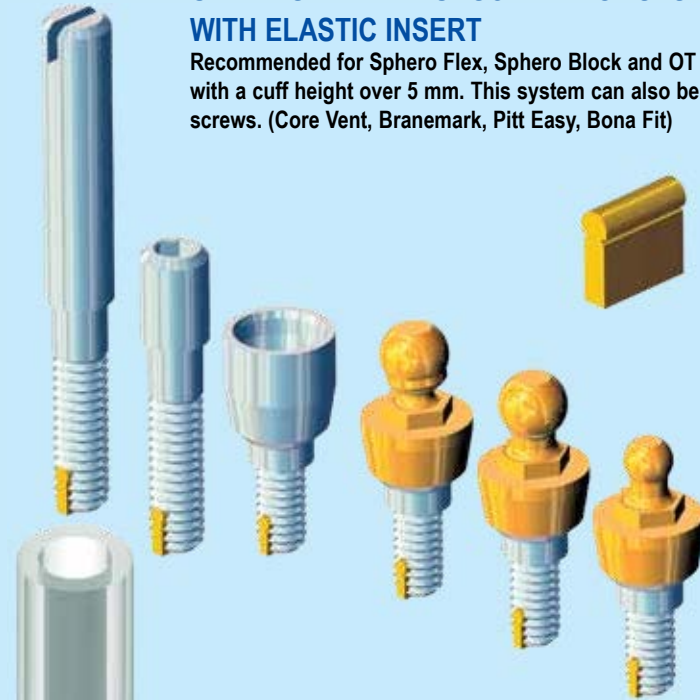

ELASTIC INSERT

This component is manufactured from bio-compatible materials with an "elastic" memory. While screwing in the attachment, the insert is compressed. When the threaded attachment is fully seated, the elastic insert will expand and return to its original form, which prevents rotation and unscrewing of the device.

The insert is applied at the manufacturing facility UPON REQUEST. It can be applied to any screw with a diameter greater than 1.8 mm.

SPHERO FLEX - SPHERO BLOCK

In order to achieve a passive fit for the final prosthesis using the **SPHERO FLEX** and **SPHERO BLOCK** attachment systems, it is necessary to use **DIRECTIONAL RINGS**. When not used, there is a high possibility that the attachments will not seat properly into the prosthesis due to incorrect positioning of the caps. This mis-alignment will result in premature wear of the caps causing additional trauma to the implant.

SELECTION OF DIRECTIONAL RINGS: The position and angulation of the implant will determine which directional ring will be used. For parallel implants, a **0° DIRECTIONAL RING** can be used. For implants that have greater divergence, a **7°** or **14°** ring can be used.

Place the **DIRECTIONAL RING** onto the hex of the attachment with the flat side down. Be sure that the ring is fully seated. Next, place the retentive cap onto the sphere and rotate the **DIRECTIONAL RING** until the cap is parallel with the other caps and are in the same horizontal plane. Doing this ensures that the retentive caps are correctly aligned inside of the final prosthesis.

NOTE: For additional information regarding cap selection, please see the **CLASSIC CAPS** section of this catalog.

LABORATORY

MINI-PARALLELOMETER

FEATURES:

- EASY TO USE
- COMPACT
- PRECISE
- ECONOMICAL



The **MINI-PARALLELOMETER** allows accurate positioning of attachments without the need for an expensive milling machine. The **MINI-PARALLELOMETER** is a useful and economical device for the laboratory technician that can be used in day-to-day operations or in a training environment.

INSTRUCTIONS FOR USE

Place the stone model on the swivel base. Rotate the base until the ideal model position is found. Insert the mandrel into the notch on the parallelometer extension arm and lock it into place by tightening the screw. Adjust the height by moving the extension arm up and down. Once the correct height has been found, lock the arm into position by tightening the rear locking screw.

CUFF HEIGHT MEASURING TOOL FOR IMPLANTS

INSTRUCTIONS FOR USE

1. Rotate the gold colored plate until the tool is completely open.
2. Insert the tool into the implant. Be sure that it is fully seated on the top of the implant.
3. Firmly hold the tool and rotate the gold plate clockwise until it contacts the ridge.
4. Remove the tool and read the color coded rings indicated on the pin to determine the cuff height.

NOTE:

When a colored ring is completely covered, and only the silver band between colors is visible, it is recommended to utilize the next (higher) color.

IMPORTANT:

Before ordering an attachment, it is necessary to specify: Implant manufacturer, implant brand, diameter, internal or external hex connection and cuff height. The cuff height is determined by taking the corresponding color from the cuff height measuring tool. For implants with an internal hex connection the cuff height will range from .5 mm to 7 mm and for implants with an external hex connection, the cuff height will range from 1 mm to 7 mm.

CUFF HIGH MEASURER

BG

To determine the tissue height above the implant and eliminate mistakes when choosing the correct attachment, the Cuff Height Measuring tool is used.

The Cuff Height Tool is compatible with all implants that have an internal or external hex connection.

Cuff Height Measuring Tool
With Threaded Pin And Ball Indicator

With easy to read color-coded millimeter measurements, Dentists and dental laboratories can accurately measure tissue height between .5 mm and 7 mm. The ball indicator outlines where the male component of the attachment will seat above the tissue.

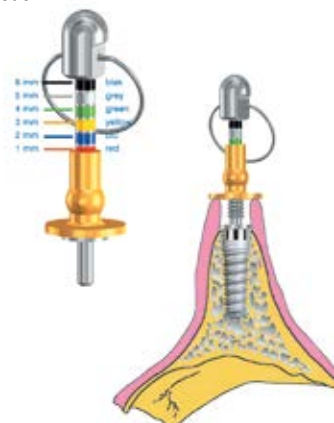

Cuff Height Measuring Tool
With Stationary Pin

The cuff height measuring tool with stationary pin provides the same functionality as the tool with a threaded pin, however it is used in cases where there is limited space between two implants.

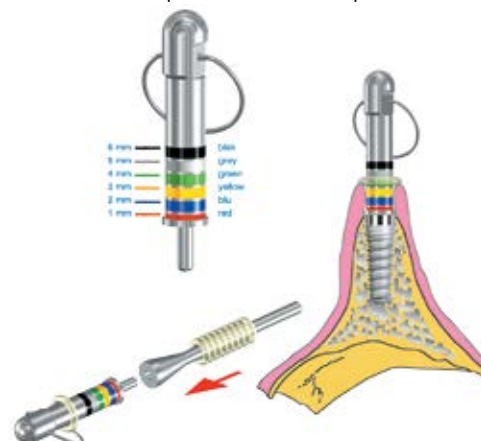

BROKEN SCREW EXTRACTOR KIT FOR IMPLANTS

FOR REMOVAL OF BROKEN IMPLANT SCREWS



READILY AVAILABLE FOR CORE VENT AND BRANEMARK COMPATIBLE IMPLANTS

EXTRACTOR KITS CAN BE MADE TO ORDER FOR MOST COMMON IMPLANT BRANDS WITH AN INTERNAL OR EXTERNAL HEX CONNECTION

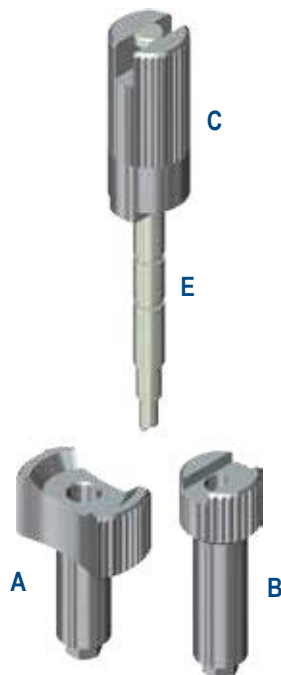

REVERSE CUTTING BUR (E)

CLAW REAMER BUR (D)

DEEP CENTERING DEVICE (B)

MANUAL CENTERING DEVICE (A)

BUR EXTENSION (C)

CLINIC



BROKEN SCREW VISIBLE IN X-RAY OF IMPLANT



BROKEN SCREW REMOVED

REMOVING THE BROKEN SCREW WITH THE CLAW REAMER BUR

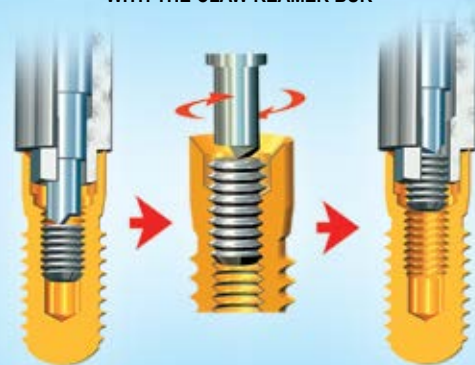

With the Rhein83 Broken Screw Extractor Kit, it is possible to remove a broken screw from an implant if it has not been bonded or damaged during previous attempts to remove it.

The extractor kit includes two types of burs; a claw reamer bur and reverse cutting bur. In addition, the kit includes manual and deep centering devices to hold the burs in place during the procedure. In 90% of cases, the broken screw can be removed easily with the claw reamer bur. However if the broken screw is frozen in place, the reverse cutting bur must be used.

Broken Screw Extractor Kits are readily available for **Core Vent** and **Branemark** compatible implant systems. Kits can be made to order for most common implant brands with an internal or external hex connection.

To order a custom kit or for technical support, please contact your local Rhein83 distributor.

PARTS AND ACCESSORIES:

- A MANUAL CENTERING DEVICE
- B DEEP CENTERING DEVICE
- C BUR EXTENSION
- D CLAW REAMER BUR
- E REVERSE CUTTING BUR

BROKEN SCREW EXTRACTOR KIT FOR IMPLANTS

FOR REMOVAL OF BROKEN IMPLANT SCREWS

USING THE REVERSE CUTTING BUR TO EXTRACT A BROKEN SCREW

Place the **reverse cutting bur** into the angled handpiece and then insert it into the respective extractor. Before activating the handpiece it is essential that the bur be in contact with the broken screw. **Activate the handpiece in a counter clockwise direction and be sure that firm downward pressure is maintained throughout the procedure. It is mandatory that the handpiece motor be operated between 2000 rpm and 6000 rpm.** To prevent the implant fixture from overheating, it is necessary to move the **reverse cutting bur** in an up and down motion intermittently. Upon removing the broken screw, be sure to clean the implant fixture thoroughly to remove any residual metal shavings that remain from the extraction procedure.



Operate at speeds not lower than 2000 rpm

NOTE: Before using, fill the bottom hole (side with the hex) of the centering device with petroleum jelly. In addition to lubricating the device, in some cases, it will hold the broken screw in the extractor upon removal.

USING THE CLAW REAMER BUR WITH THE MANUAL CENTERING DEVICE



Fig.1

While holding the manual centering device firmly, insert the device (A) into the fixture and make sure that the hexagon is fully engaged into the implant fixture.



Fig.2

Insert the claw reamer bur (D) into extension (C). Insert the bur into the centering device until it comes into contact with the broken screw. Rotate in a counter clockwise direction while maintaining constant downward pressure. After a few turns the notch in the bur should reappear. Manually remove the centering device which will contain the screw, if not it will remain inside the implant and can easily be removed with tweezers.



Fig.3

In certain cases, it may be easier to use the claw reamer bur (D) with a right angle handpiece. With the motor **stopped**, insert the claw reamer bur into the centering device (A) until the tip touches the broken screw.



Fig.4

While applying pressure to the broken screw, start the motor in a **COUNTER CLOCKWISE** direction at a low RPM. After a few turns the notch in the bur should reappear. Manually remove the centering device which will contain the screw, if not it will remain inside the implant and can easily be removed with tweezers.

STABILIZING THE EXTRACTOR WITH ADJACENT TEETH OR FIXTURES



Fig.5

In cases where the implant fixture is buried deep (7 - 10 mm) in the tissue, and it is difficult to hold the deep centering device (B) steady with your fingers; Insert the extractor into the deep centering device and use the bur extension (C) to push the extractor into the fixture. Be sure that the hex is fully engaged into the implant. In order to hold this position, use a self curing resin to attach the device to the adjacent teeth.



Fig.6

In cases where teeth are missing, mount the analogues onto the abutment or mount using simple screws. Fix the entire structure with resin. Remove the extension and proceed with the long bur, as described for the preceding system.

IMPORTANT: Please follow the instructions closely when using the Broken Screw Extractor Kit. Although the **Reverse Cutting Bur** has been hardened by a tempering process, it should always remain vertical (parallel with the screw hole) during the procedure to prevent breakage. The **Reverse Cutting Bur** and **Claw Reamer Bur** are subject to wear. These burs should be inspected for wear prior to each procedure and replaced if necessary. Finally, it is very important that the motor direction is set to COUNTER CLOCKWISE when using this kit.

INSTRUCTIONS AND TECHNICAL ADVICE



REPLACEMENT OF CAPS

Rhein83 recommends that caps be replaced every 12 months. The longevity of the caps is affected by many variables including: original case design, patient hygiene and general maintenance of the prosthesis.



HOW TO REPLACE THE CAPS

In a prosthesis with metal housings, the cap can be removed by using a rotary instrument operated at a low RPM. Be careful not to damage the metal housing during this procedure. The **cap extractor tool** available from Rhein83 can also be used.



In a prosthesis where the cap is incorporated directly into the resin, it can be removed by hand with a pointed instrument (such as a spatula) or the Rhein83 **cap extractor tool**. If a bur is used, be careful to remove only the retentive cap and to not modify the form that remains in the resin. If the resin site is damaged during the removal of the cap, repair the area with self curing resin before inserting the new cap. The **cap insertion tool** is used for this procedure.



GREEN ELASTIC CAPS

These caps are highly elastic and have a medium level of retention. In cases where metal housings are used, it is recommended to apply a drop of adhesive (cyanoacrylic) on the inside of the housing before inserting the cap.



TITAN CAPS

These caps were designed to be used on the **OT CAP TECNO** as well as the Normal and Micro attachments with machined titanium spheres.



CAP INSERTION TOOL

When using high retention caps, it is recommended to insert them directly chairside onto the attachment using the cap insertion tool.

OT CAP Normal / Micro OT Reverse.



PROSTHESES WITH MULTIPLE ATTACHMENTS

In order to balance the retentive levels of a prosthesis with multiple attachments, it is possible to use caps with different levels of retention in the final case design.

REAMERS AND CAP TESTERS: in a case where only caps with too high of a retention strength are available, insert the reamer into the caps and rotate it in a clockwise direction, after only a few rotations it will wear down the perimeter which will reduce the retention. Try the prosthesis in the mouth, if it is still too retentive, repeat the operation with the reamer. In order to avoid trying the prosthesis in the mouth too many times, one can use the spherical tester, in order to evaluate the holding strength.



HOW THE RETENTIVE CAP FUNCTIONS

The **Rhein83** caps are manufactured with a high elasticity which creates both mechanical and frictional retention resulting in a larger contact zone between the cap and the lower portion of the sphere. A small space between the metal housing and the cap allows the cap to expand as it passes over the equator of the sphere. Once completely engaged, the cap returns to its original form.



POLISHING OF THE "CAST" ATTACHMENTS:

It is recommended that only glass beads or a soft cloth wheel are used to polish attachments. In order to avoid damage to the sphere during these procedures, it is a good practice to cover the spheres with a retentive cap. The retentive caps can be reused again for this procedure.

TRADITIONAL PROSTHESES



REF.

DESCRIPTION

06P

Model with upper prosthesis with OT Cap
Normal / Micro size attachments:
 1 OT CAP NORMAL
 1 OT CAP MICRO
 1 Frame with OT BOX mono housings
 5 Acrylic teeth



07P

Model with lower prosthesis with OT Strategy
 1 OT STRATEGY
 1 OT STRATEGY + STEADY
 1 Frame with caps and duplicated housings
 5 Acrylic teeth



04P

PROSTHESIS ON NATURAL TEETH
Model with lower "Overdenture" prosthesis:
 1 PIVOT FLEX titanium post
 1 Cast post with OT CAP sphere
 1 Complete denture with 14 teeth
 1 Cast OT BOX reinforcement incorporated in the denture

04P/A

Same model as 04P. Denture with pre-fabricated STAINLESS STEEL HOUSINGS for retentive caps



09P

MODEL WITH LOWER PROSTHESIS WITH OT VERTICAL
 1 OT VERTICAL
 1 OT VERTICAL + STEADY
 1 Frame with clips and duplicated housing
 6 Acrylic teeth



031

IMPLANT MODELS
Model with lower prosthesis with SPHERO FLEX abutments:
 2 Implant analogs
 1 SPHERO FLEX
 1 SPHERO BLOCK
 1 Complete denture with 14 teeth
 1 Cast OT BOX reinforcement incorporated in the denture

031/A

Same model as 031. Denture with pre-fabricated STAINLESS STEEL HOUSINGS



08B

PROSTHESIS ON FIXTURES
Model with lower prosthesis with OT Bar Multiuse:
 2 Implant analogs
 1 Cast bar with copings
 1 OT BAR MULTIUSE
 1 Cast superstructure with two retentive clips
 1 Complete denture with 14 teeth

PRODUCT SPECIFICATIONS

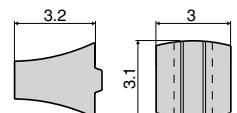
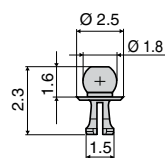
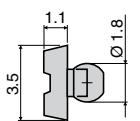
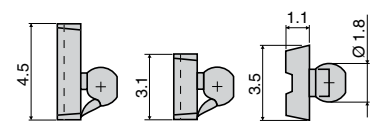
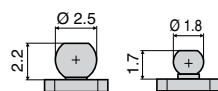
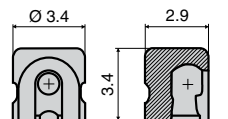
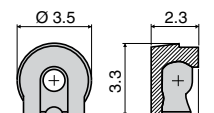
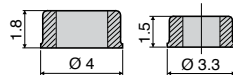
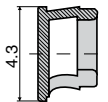
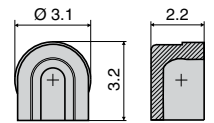
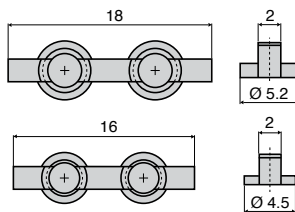
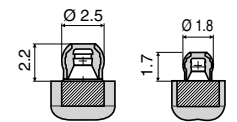
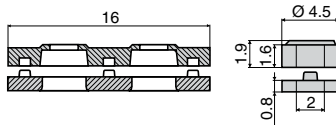
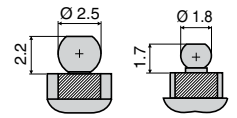
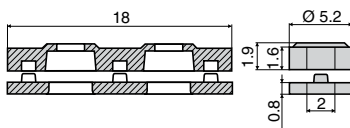
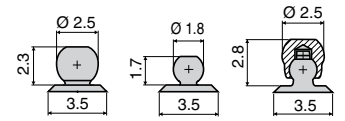
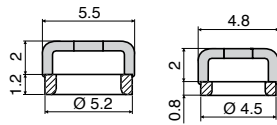

PRODUCT RANGE - SIZES AND DIMENSIONS

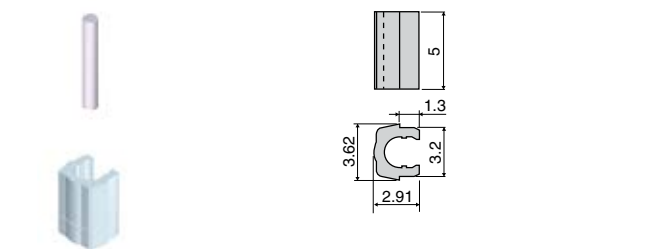
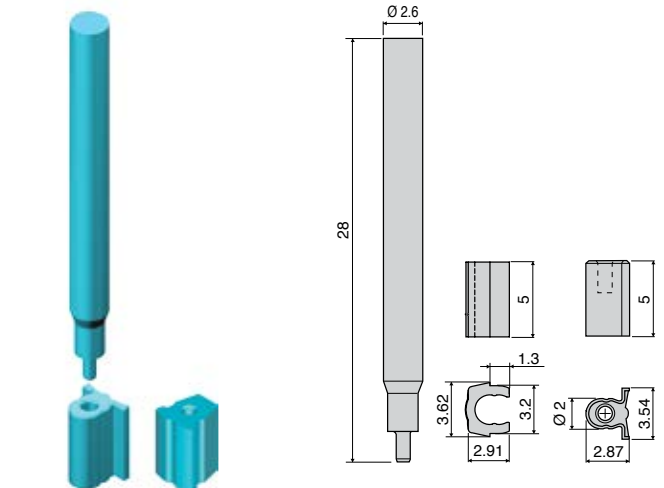
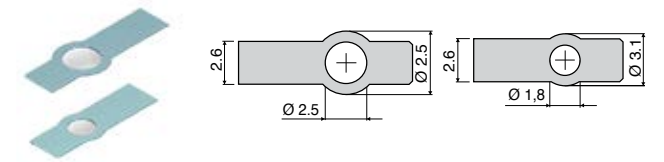
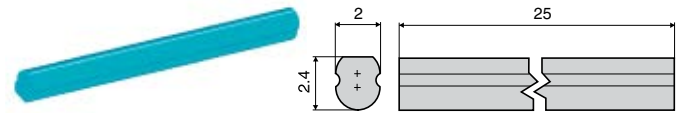
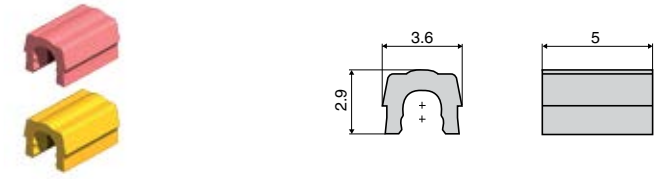
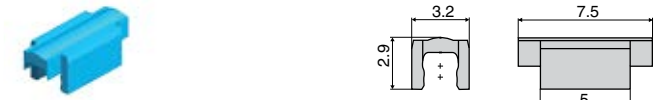
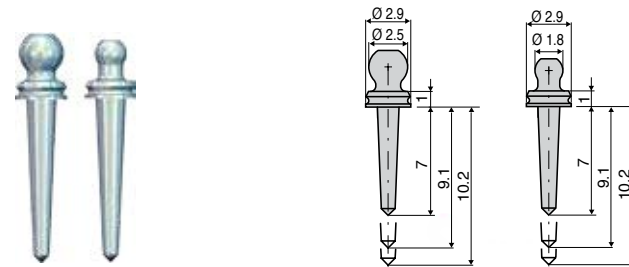
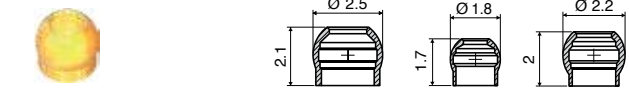
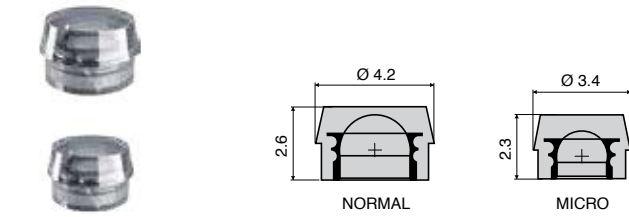
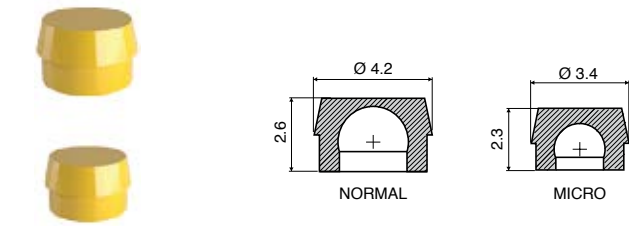
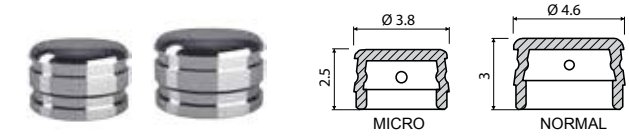

PRODUCT SPECIFICATIONS

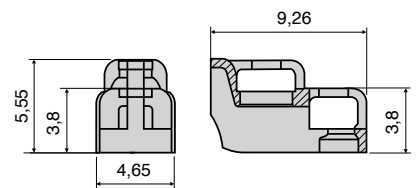
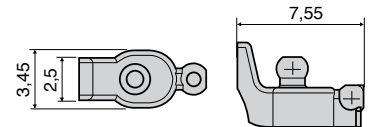
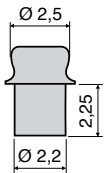
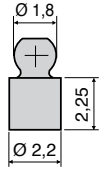
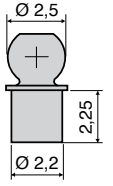
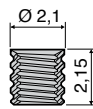
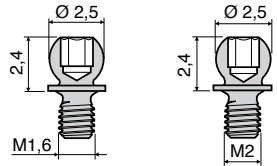
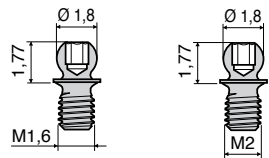
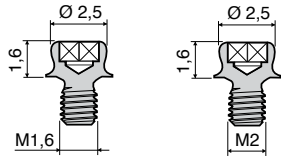
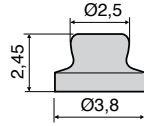
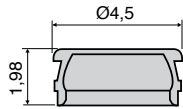



Ref.: 005SKLUS
INTRODUCTORY KIT FOR LABORATORY
 contains assorted attachments and tools



Ref.: 011SPL
S.P.L. INTRODUCTORY KIT
 contains assorted titanium BLOCK pivots, castable pivots, retentive caps and two regulating tools

ATTACHMENTS OT CAP SYSTEM



Ref.: 038STF

TITANIUM FLEX SINGLE SPHERE NORMAL SIZE + TiN
 Kit contains
 2 SINGLE TITANIUM SPHERES
 2 PINK CAPS - SOFT RETENTION
 1 SPHERE HOLDER
 2 CASTABLE SLIDING BASES



Ref.: 090TCN

OT CAP TECNO - TITAN CAP NORMAL SIZE
 Kit contains
 1 OT CAP TECNO BAR
 2 CONCAVE TITANIUM SPHERES - TIN COATED
 2 TITAN CAPS
 1 INSERTION TOOL



Ref.: 038STN

TITANIUM SINGLE SPHERE NORMAL SIZE + TiN
 Kit contains
 2 SINGLE TITANIUM SPHERES
 2 PINK CAPS - SOFT RETENTION
 1 SPHERE HOLDER
 2 CASTABLE SLIDING BASES



Ref.: 090TCM

OT CAP TECNO - TITAN CAP MICRO SIZE
 Kit contains
 1 OT CAP TECNO BAR
 2 CONCAVE TITANIUM SPHERES - TIN COATED
 2 TITAN CAPS
 1 INSERTION TOOL



Ref.: 038STM

TITANIUM SINGLE SPHERE MICRO SIZE + TiN
 Kit contains
 2 SINGLE TITANIUM SPHERES
 2 PINK CAPS - SOFT RETENTION
 1 SPHERE HOLDER
 2 CASTABLE SLIDING BASES



Ref.: 058BSN

OT BOX SPECIAL NORMAL SIZE + CONNECTORS
 Kit contains
 2 OT BOX SPECIAL BARS
 4 PLASTIC POSITIONERS
 4 CONNECTORS



Ref.: 092CAN

OT CAP NORMAL SIZE
 Kit contains
 4 SINGLE SPHERES
 4 PINK RETENTIVE CAPS
 4 STAINLESS STEEL HOUSINGS (2 for resin - 2 for soldering)
 4 PLASTIC POSITIONING RINGS



Ref.: 058BSM

OT BOX SPECIAL MICRO SIZE + CONNECTORS
 Kit contains
 2 OT BOX SPECIAL BARS
 4 PLASTIC POSITIONERS
 4 CONNECTORS



Ref.: 092CAM

OT CAP MICRO SIZE
 Kit contains
 4 SINGLE SPHERES
 4 PINK RETENTIVE CAPS
 4 STAINLESS STEEL HOUSINGS (2 for resin - 2 for soldering)
 4 PLASTIC POSITIONING RINGS



Ref.: 153BCN

OT BOX CLASSIC NORMAL SIZE + CONNECTORS
 Kit contains
 2 UPPER BARS
 2 LOWER BARS
 4 PLASTIC POSITIONERS
 4 CONNECTORS



Ref.: 196BCN

"ECONOMIC" OT CAP NORMAL SIZE
 Kit contains
 1 CASTABLE BAR
 1 CASTABLE BEVELLED BAR
 4 CLEAR RETENTIVE CAPS (Standard retention)



Ref.: 153BCM

OT BOX CLASSIC MICRO SIZE + CONNECTORS
 Kit contains
 2 UPPER BARS
 2 LOWER BARS
 4 PLASTIC POSITIONERS
 4 CONNECTORS



Ref.: 197BCM

"ECONOMIC" OT CAP MICRO SIZE
 Kit contains
 1 CASTABLE BAR
 1 CASTABLE BEVELLED BAR
 4 CLEAR RETENTIVE CAPS (Standard retention)



Ref.: 087CRS

CONCAVE RECONSTRUCTIVE SPHERE
 Kit contains
 2 CONCAVE SPHERES IN TITANIUM - TIN COATED
 2 PINK CAPS SOFT RETENTION
 1 INSERTION TOOL
 1 GAUGE AND STRIP HOLDER
 Available in 1.8 mm, 2.2 mm, 2.5 mm diameters



Ref.: 099BSN

OT CAP & MONO OT BOX FOR FRAME NORMAL SIZE
 Kit contains
 2 CASTABLE BARS (1 straight - 1 bevelled)
 4 CLEAR RETENTIVE CAPS
 4 CASTABLE MONO OT BOX
 4 PLASTIC POSITIONING RINGS



Ref.: 089SRS

SOLID RECONSTRUCTIVE SPHERE
 Kit contains
 2 SOLID SPHERES IN TITANIUM - TIN COATED
 2 PINK CAPS SOFT RETENTION
 2 PROTECTIVE DISKS
 1 KEY
 Available in 1.8 mm diameter



Ref.: 099BSM

OT CAP & MONO OT BOX FOR FRAME MICRO SIZE
 Kit contains
 2 CASTABLE BARS (1 straight - 1 bevelled)
 4 CLEAR RETENTIVE CAPS
 4 CASTABLE MONO OT BOX
 4 PLASTIC POSITIONING RINGS



Ref.: 064ACN NORMAL
Ref.: 064ACM MICRO

ASSORTED RETENTIVE CAPS
 Kit NORMAL - Kit MICRO
 6 CLEAR CAPS - STANDARD RETENTION
 6 PINK CAPS - SOFT RETENTION
 6 YELLOW CAPS - EXTRA SOFT RETENTION
 6 GREEN CAPS - VERY ELASTIC RETENTION

S.P.L. PIVOTS - COPING COVER



Ref.:
033PSF

PIVOT FLEX - TITANIUM PIVOT WITH SWIVEL SPHERE NORMAL SIZE (Ø 2.5 mm) FOR DIRECT OVERDENTURE (3 Sizes available)

- Kit contains
- 1 TITANIUM PIVOT WITH SWIVEL SPHERE (adapted for COPING COVER)
 - 1 STAINLESS STEEL HOUSING FOR RESIN
 - 2 PINK CAPS Normal Size - Soft retention
 - 1 ALUMINIUM DISK
 - 3 DIRECTIONAL RINGS

Sfera Normo ø 2,5
Sfera Micro ø 1,8



Ref.:
036PTN

TITANIUM PIVOTS Normal Size Adapted for COPING COVER

- Kit contains
- 5 TITANIUM PIVOTS Sphere 2.5 mm

Ref.:
036PTM

TITANIUM PIVOTS Micro Size Adapted for COPING COVER

- Kit contains
- 5 TITANIUM PIVOTS Sphere 1.8 mm



Ref.:
037CCL

COPING COVER - FOR OVER CASTING

- Kit contains
- 1 ASSEMBLING RING FOR PIVOTS
 - 2 SPRINGS



Ref.:
010PSP

CASTABLE PIVOTS NORMAL SIZE



Ref.:
012PSM

CASTABLE PIVOTS MICRO SIZE



Ref.:
A01MOG

MOOSER BUR

Reamer for post 7 mm, 9 mm, 10 mm

Ref.:
A03MOB

MOOSER BUR

Reamer for post 12 mm, 14 mm



Ref.:
085IAC

INSERTION TOOL FOR CAPS OT CAP NORMAL AND MICRO SIZE



Ref.:
74AC01

PARALLELOMETER KEY FOR OT CAP NORMAL SIZE



Ref.:
74AC02

PARALLELOMETER KEY FOR OT CAP MICRO SIZE



Ref.:
74GTN

PARALLELOMETER KEY FOR OT CAP TECNO NORMAL SIZE (GOLD COLOR)



Ref.:
74GTM

PARALLELOMETER KEY FOR OT CAP TECNO MICRO SIZE (GOLD COLOR)



Ref.:
080RCN

REAMER TOOL FOR CAPS OT CAP NORMAL SIZE



Ref.:
080RCM

REAMER TOOL FOR CAPS OT CAP MICRO SIZE



Ref.:
082ATN

TOOL FOR TESTING CAP RETENTION OT CAP NORMAL SIZE



Ref.:
083ATM

TOOL FOR TESTING CAP RETENTION OT CAP MICRO SIZE



Ref.:
124ICP

TOOL FOR TESTING CAPS IN THE MOUTH OF THE PATIENT OT CAP NORMAL - MICRO - OT REVERSE

Ref.:
078AUB

KIT WITH TOOLS FOR DENTIST, CONTAINS: CODES: 080RCN - 080RCM - 085IAC - 086ICS - 084ICP

OT STRATEGY ATTACHMENTS



Ref.:
098SSSUS

OT STRATEGY CAPS FOR DUPLICATION TECHNIQUE

- Kit contains
- 4 CASTABLE MALES 2 Standard + 2 High
 - 2 CASTABLE STEADY
 - 4 RETENTIVE CAPS



Ref.:
098CALUS

OT STRATEGY CAPS FOR DUPLICATION TECHNIQUE

- Kit contains
- 4 CASTABLE MALES (2 Standard + 2 High)
 - 2 CASTABLE STEADY
 - 4 STAINLESS STEEL HOUSINGS
 - 2 POSITIONING RINGS
 - 4 RETENTIVE CAPS



Ref.:
047ACS

OT STRATEGY ASSORTMENT CAP KIT FOR DUPLICATION TECHNIQUE

- Kit contains
- 4 YELLOW CAPS - EXTRA SOFT RETENTION
 - 4 PINK CAPS - SOFT RETENTION
 - 4 CLEAR CAPS - STANDARD RETENTION



Ref.:
045ACS

OT STRATEGY ASSORTMENT CAP KIT FOR STAINLESS STEEL HOUSINGS

- Kit contains
- 4 YELLOW CAPS - EXTRA SOFT RETENTION
 - 4 PINK CAPS - SOFT RETENTION
 - 4 CLEAR CAPS - STANDARD RETENTION



Ref.:
086ICS

INSERTION TOOL FOR CAPS OT STRATEGY



Ref.:
75AC04

PARALLELOMETER KEY FOR OT STRATEGY



Ref.:
081RCS

REAMER TOOL FOR CAPS OT STRATEGY

OT BAR MULTIUSE ATTACHMENTS



Ref.:
021OBM

OT BAR MULTIUSE

- Kit contains
- 2 BARS
 - 4 POSITIONING CLIPS A
 - 4 POSITIONING CLIPS B
 - 4 BOXES
 - 4 RETENTIVE PINK CLIPS
 - 4 RETENTIVE YELLOW CLIPS
 - 2 CONNECTORS
 - 1 GINGIVAL CONNECTOR



Ref.:
029OIC

INSERTION TOOL FOR OT BAR CLIPS



Ref.:
028OCP

PARALLELOMETER KEY FOR OT BAR MULTIUSE

OT VERTICAL ATTACHMENTS



Ref.:
071OBV

OT VERTICAL

- Kit contains
- 4 CASTABLE MALES
 - 4 CASTABLE STEADY
 - 4 RETENTIVE WHITE CLIPS
 - 2 RETENTIVE GREEN CLIPS
 - 4 CERAMIC PINS
 - 4 CASTABLE PARALLELOMETER KEYS + PIN



Ref.:
072ICV

INSERTION TOOL FOR OT VERTICAL CLIPS



OT EQUATOR CASTABLE



Ref.:
▶ 092ECQ

OT EQUATOR CASTABLE

- Kit Contains:**
- 2 CASTABLE MALES
 - 2 STAINLESS STEEL HOUSINGS
 - 4 RETENTIVE CAPS
2 PINK - SOFT
2 CLEAR - STANDARD

OT EQUATOR FOR IMPLANTS



Ref.:
▶ 130

OT EQUATOR FOR IMPLANTS

- Kit Contains:**
- 1 OT EQUATOR
 - 1 STAINLESS STEEL HOUSING
 - 1 PROTECTIVE DISK
 - 4 RETENTIVE CAPS
1 YELLOW - EXTRA SOFT 1 CLEAR - STANDARD
1 PINK - SOFT 1 VIOLET - RIGID



Ref.:
▶ 030

- 1 OT EQUATOR ABUTMENT
*Compatible with ALL implant systems

OT EQUATOR BAR

**OT EQUATOR WITH THREADED SLEEVE
For Bonding**



Ref.:
▶ 160EQB

- Kit Contains:**
- 2 THREADED OT EQUATOR - 1.6 mm thread
 - 2 THREADED SLEEVES - 1.6 mm thread
 - 2 STAINLESS STEEL HOUSINGS
 - 2 WAXING SPACERS
 - 8 RETENTIVE CAPS
-2 YELLOW - EXTRA SOFT
-2 PINK - SOFT
-2 CLEAR - STANDARD
-2 BLACK - PROCESSING



Ref.:
▶ 039SFE2

- 1 THREADED OT EQUATOR
2 mm universal thread

OT EQUATOR ELASTIC SEEGER

Passive Bar Connection



Ref.:
▶ 158EQS

ELASTIC SEEGER

- Kit Contains:**
- 2 CASTABLE CYLINDER HOUSINGS
For Seeger
 - 3 RED PLASTIC SEEGERs
For Laboratory
 - 3 RETENTIVE ELASTIC SEEGERs
To Lock The Bar
 - 2 THREADED LOCKING SCREWS
For OT Equator

TOOLS



Ref.:
▶ 74AC01

- PARALLELOMETER KEY
NORMAL



Ref.:
▶ 774CQ

- OT EQUATOR SQUARE DRIVER
1.25 mm



Ref.:
▶ 760CE

- OT EQUATOR TORQUE CONNECTOR
1.25 mm



Ref.:
▶ 124ICP

- BLU PLASTIC "MULTIUSE" INSERTION
TOOL
(use together with metal insertors)



Ref.:
▶ 085SIS

- STEEL INSERTION TOOL FOR SEEGER
For use with Universal Handle 124ICP



Ref.:
▶ 191ECS

- STEEL EXTRACTOR TOOL FOR CAPS
For use with Universal Handle 124ICP

ACCESSORIES:



Ref.:
▶ 044CAIN

- 2 IMPRESSION TRANSFER
(pick up impression)



Ref.:
▶ 144MTE

- 2 IMPRESSION TRANSFER



Ref.:
▶ 144AE

- 2 STAINLESS STEEL ANALOGS
For OT Equator



Ref.:
▶ 185IAC

- METAL INSERTION TOOL FOR CAPS
(use together with 124ICP BLU HANDLE)

SPARE PARTS:

OT EQUATOR CAP ASSORTMENT KIT



Ref.:
▶ 192ECE

- Kit Contains:**
- 1 STAINLESS STEEL HOUSING
 - 1 BLACK CAP - PROCESSING
 - 4 RETENTIVE CAPS:
-1 YELLOW - EXTRA SOFT - 1 PINK - SOFT
-1 CLEAR - STANDARD - 1 VIOLET - RIGID
-1 BLACK - PROCESSING - 1 PROTECTIVE DISK

OT CAP / OT EQUATOR IMPRESSION COPINGS



Ref.:
▶ **044CAIN**

- 2 STAINLESS STEEL IMPRESSION COPINGS
For OT CAP Normal and OT EQUATOR



Ref.:
▶ **044CAIM**

- 2 STAINLESS STEEL IMPRESSION COPINGS
For OT CAP Micro

TOOLS



Ref.:
▶ **772CSF**

- HEX DRIVER - 0.9 mm
For Threaded Micro Sphere

SINGLE THREADED SPHERES WITH THREADED BONDING SLEEVE



Ref.:
▶ **139KSFN**

Titanium + TiN Threaded Sphere With Sleeve For Bonding Kit - NORMAL SIZE

- Kit contains:**
- 2 TITANIUM SINGLE THREADED SPHERES
1.3 mm Hex, 1.6 mm Thread
 - 2 TITANIUM THREADED SLEEVES
For Bonding
 - 2 WAXING SPACERS
For Threaded Sphere - Normal Size



Ref.:
▶ **139KSFM**

Titanium + TiN Threaded Sphere With Sleeve For Bonding Kit - MICRO SIZE

- Kit contains:**
- 2 TITANIUM SINGLE THREADED SPHERES
0.9 mm Hex, 1.6 mm Thread
 - 2 TITANIUM THREADED SLEEVES
For Bonding
 - 2 WAXING SPACERS
For Threaded Sphere - Micro Size

SINGLE THREADED SPHERES

NORMAL - MICRO



Ref.:
▶ **039SFN2**

- 1 TITANIUM + TiN THREADED SPHERE - NORMAL
1.3 mm Hex, 2.0 mm Thread



Ref.:
▶ **039SFM2**

- 1 TITANIUM + TiN THREADED SPHERE - NORMAL
0.9 mm Hex, 2.0 mm Thread

OT LOCK



Ref.:
▶ **880CLT**

OT LOCK KIT

- Kit contains:**
- 1 COMPLETE OT LOCK
 - 1 BRASS POSITIONER
 - 1 CERAMIC PIN



Ref.:
▶ **880CLR**

ADJUSTABLE OT LOCK KIT

- Kit contains:**
- 1 COMPLETE ADJUSTABLE OT LOCK
 - 1 EXTENDED BRASS POSITIONER
 - 1 CERAMIC PIN
 - 9 CASTABLE SPACER RINGS

OT LOCK SPARE PARTS



Ref.:
▶ **882CG**

- CONICAL GUIDE



Ref.:
▶ **882CAS**

- UNLOCKING TOOL

INCLUDES OT CAP & OT BOX - OT STRATEGY - OT BAR - OT VERTICAL - OT UNILATERAL - OT EQUATOR

"BASIC" PROMOTIONAL KIT FOR LABORATORY



Ref.:
▶ **005SKLBUS**

Kit contains:

OT CAP - OT BOX:

- 16 ASSORTED CASTABLE PIVOTS NORMAL / MICRO
- 4 CASTABLE SPHERES NORMAL / MICRO
- 2 CASTABLE OT CAP BARS NORMAL / MICRO
- 2 CASTABLE OT BOX BARS CLASSIC (top + bottom) NORMAL / MICRO
- 1 CASTABLE OT BOX SPECIAL BARS NORMAL / MICRO
- 6 CASTABLE OT BOX CONNECTORS
- 4 CASTABLE OT BOX MONO HOUSING NORMAL / MICRO
- 8 POSITIONER RINGS NORMAL / MICRO
- 28 OT CAP RETENTIVE CAPS NORMAL / MICRO
YELLOW, PINK, CLEAR, GREEN
- 9 BLACK CAPS - FOR PROCESSING NORMAL / MICRO
- 4 STAINLESS STEEL HOUSINGS NORMAL / MICRO FOR RESIN

OT STRATEGY:

- 4 OT STRATEGY MALES - 2 STANDARD BASE - 2 LONG BASE
- 2 CASTABLE STEADY
- 6 OT STRATEGY CAPS FOR STAINLESS STEEL HOUSING
YELLOW, PINK, CLEAR

TOOLS:

- 1 TWEEZER
- 1 PARALLELOMETER KEY OT CAP NORMO
- 1 PARALLELOMETER KEY OT CAP MICRO
- 1 PARALLELOMETER KEY OT STRATEGY
- 1 PARALLELOMETER KEY OT BAR MULTIUSE
- 1 BLUE PLASTIC UNIVERSAL INSERTION HANDLE
- 1 INSERTION TOOL - OT CAP NORMAL / MICRO
- 1 INSERTION TOOL - OT STRATEGY
- 1 INSERTION TOOL - OT BAR MULTIUSE
- 1 INSERTION TOOL - OT VERTICAL

OT STRATEGY CONTINUED:

- 2 OT STRATEGY STAINLESS STEEL HOUSINGS
- 2 OT STRATEGY PLASTIC POSITIONING RINGS
- 6 OT STRATEGY CAPS FOR DUPLICATION TECHNIQUE
YELLOW, PINK, CLEAR
- 4 BLACK CAPS - PROCESSING (for wax and for duplication technique)

OT EQUATOR:

- 2 CASTABLE MALES
- 2 STAINLESS STEEL HOUSINGS
- 4 RETENTIVE CAPS - 2 PINK, 2 CLEAR
- 2 BLACK CAPS FOR LABORATORY USE

OT UNILATERAL:

- 1 CASTABLE ATTACHMENT WITH COMBINED SPHERES
- 1 CASTABLE UNI-BOX
- 1 MICRO POSITIONING RING
- 2 OT CAP MICRO CAPS - 1 PINK, 1 BLACK
- 2 OT STRATEGY CAPS - 1 PINK, 1 BLACK
For Duplication Technique
- 1 CONNECTOR

OT BAR MULTIUSE:

- 1 CASTABLE BARS
- 1 BAR EXTENSION
- 4 POSITIONING CLIPS (Type A - Type B)
- 2 CASTABLE BOXES
- 4 CLIPS - 2 PINK, 2 YELLOW

OT VERTICAL:

- 2 CASTABLE MALES
- 2 CASTABLE STEADY
- 4 CLIPS - 2 WHITE, 2 GREEN
- 2 PARALLELOMETER KEYS + PIN
- 2 CERAMIC PINS

IMPLANTOLOGY

SPHERO FLEX - BLOCK SYSTEM TITANIUM ATTACHMENTS FOR OVERDENTURES



- Ref.: **109**
- 1 Titanium Abutment with self-aligning 2.5 mm sphere
 - 2 Pink Caps - Soft Retention
 - 1 Stainless Steel Housing
 - 1 Protective Disk
 - 3 Directional Rings



- Ref.: **002**
- 1 Titanium Abutment with stationary 2.5 mm sphere
 - 2 Pink Caps - Soft Retention
 - 1 Stainless Steel Housing
 - 1 Protective Disk
 - 3 Directional Rings



- Ref.: **003**
- 1 Titanium Abutment with stationary 1.8 mm sphere
 - 2 Pink Caps - Soft Retention
 - 1 Stainless Steel Housing
 - 1 Protective Disk
 - 3 Directional Rings

ANCILLARY ITEMS

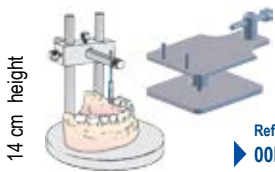

- Ref.: **00PB**
- MINI PARALLELOMETER WITH UNIVERSAL TILTING MODEL TABLE (FOR LABORATORY USE, COURSES, ETC.)**



- Ref.: **NC**
- Rhein83 Composite Material**
2-Part anaerobic composite cement for metal to metal bonding

SPHERO FLEX / SPHERO BLOCK TOOLS



- Ref.: **771CEF**
- UNIVERSAL KEY FOR SPHERO FLEX AND SPHERO BLOCK - NORMAL / MICRO**
Hex 2.3 mm



- Ref.: **760CBM**
- HEX DRIVER FOR CONTRA-ANGLE TORQUE CONTROLLER**



- Ref.: **760CBR**
- SCREW DRIVER FOR OT REVERSE THREADED SPHERE NORMAL**
Hex 1.3 mm

SPECIALTY ITEMS FOR IMPLANTS



- Ref.: **008MBG**
- CUFF HEIGHT MEASURING TOOL**
Kit contains:
- 1 CUFF HEIGHT SLIDER GAGUE
 - 1 CUFF HEIGHT FIXED ROD GAGUE
 - 1 SILICON RINGS DISPENSER
 - 20 SILICON RINGS



- BROKEN SCREW EXTRACTOR KIT**
For removing broken screws from implants

- Kit contains:
- 1 MANUAL CENTERING DEVICE
 - 1 DEEP CENTERING DEVICE
 - 1 EXTENSION HOLDER
 - 1 CLAW REAMER BUR
 - 1 REVERSE CUTTING BUR
- Kit contains:
- 1 CLAW REAMER BUR
 - 1 REVERSE CUTTING BUR

- Ref.: **780E** for CORE VENT COMPATIBLE
Ref.: **781E** for BRANEMARK COMPATIBLE

- Ref.: **780**
Ref.: **780FL**

IMPLANTOLOGY

ACCESSORIES FOR IMPLANTS

For information on abutments for other implant systems please contact Rhein83



- Ref.: **108CV**

- Screw Vent Castable Abutment - Non-Rotating**
with titanium screw
White - Precision Hex
3.5 mm diameter



- Ref.: **108AVB**

- Screw Vent Castable Abutment - Non-Rotating**
with titanium screw
Red - Conical Hex For Bar Connections
3.5 mm diameter



- Ref.: **108BRK**

- Branemark Castable Abutment - Rotating**
with titanium screw
3.75 mm - 4.0 mm diameter



- Ref.: **108BRK-NR**

- Branemark Castable Abutment - Non-Rotating**
with titanium screw
3.75 mm - 4.0 mm diameter



- Ref.: **108PE**

- Pitt Easy Castable Abutment - Non-Rotating**
with titanium screw
3.25 mm - 3.75 mm - 4.0 mm diameter



- Ref.: **108BFT**

- Straumann ITI Castable Abutment - Rotating**
with titanium screw for bar connections



- Ref.: **113BFT**

- Steel Transfer Abutment For Straumann ITI Implant**
with titanium screw



- Ref.: **FA004**

- Steel Analog For Straumann ITI Implant**

Rhein83 manufactures castable abutments and titanium screws for most implant systems. For implant systems that are not listed in this catalog, please contact Rhein83 for additional information.



Rhein83 Attachment Systems are exclusively imported and distributed throughout North America by American Recovery Inc. located just 30 minutes from Mid-Town Manhattan in New Rochelle, New York.

Since 1992, Joe Tambasco President of American Recovery has closely collaborated with Claudia Nardi, President and Gianni Storni MDT, VP Technology of Rhein83 srl. promoting, conducting NBC Approved Continuing Education programs and technically supports Rhein83 products and services for dentists, dental technicians, and its dealer network.

The new office will take the theoretical and practical courses that entitle to 6 credit hours (CDT's), being the presenters, registered with "National Board for Certification in Dental Laboratory Technology, Inc."

The office is structured with a courses laboratory that can accommodate up to 12 dental technicians at a time and usually take place on Saturday.

A large photograph of the New York City skyline at night, with the city lights reflecting on the water and a bridge visible on the right side.

RHEIN 83[®] USA

466 Main Street - Lower Level • New Rochelle, NY 10801
Toll Free 877-778-8383
Tel. 914-235-0096 • Fax 914-633-6363



Rhein'83 Instructors

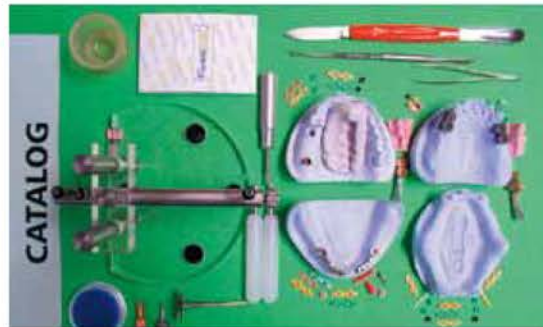

materials utilized during the courses

For more than 15 years Rhein'83 has been offering courses to teach how to use its products.

One of the reasons why these courses have attracted so much attention, is the idea of being able to construct parts of a prosthesis by assembling prefabricated castable components.

This is an important innovation in the field of dentistry.

In addition, with only a small investment, the laboratory technician is able to have a large enough assortment of components, that enables him to construct every type of traditional prosthesis.

Considering, the number of the dental technicians that attend these courses,

the series of new products that were just recently introduced to the market and those currently

under development, it is for all these reasons that Rhein'83 intends to promote and intensify all the courses. It will offer future courses both in and outside of Italy.

Continuing Education For Dentists and Dental Technicians

Educational Seminars

Case Planning Service

Interactive Website

Hands-On Courses

Technical Manual

Technical DVD

Company Directory

Customer Service:

Tel. +39 051 244510 - 244396

Fax +39 051 245238

Rhein'83 INTERNET: www.rhein83.com

E-mail:

info@rhein83.com

Sales Dep.:

angela.internationaltrade@rhein83.it

Technical support:

gianni.storni@rhein83.it

RHEIN83[®] Srl



Via E. Zago, 10
40128 (Bologna) Italy
Tel. (+39) 051 244510 - (+39) 051 244396
Fax (+39) 051 245238



<http://www.rhein83.com> • [e-mail:info@rhein83.com](mailto:info@rhein83.com)

Distributors



RHEIN83[®] Srl

ACCESSORIES for IMPLANTS



Code list

Compatible components for Screw Vent implants

ex: LEADER Ø 3,75 - BIO HORIZON Ø 3,75 int hex - EASY GRIP Ø 3,75 - DENTAL TECH Ø 3,75 -ESTHETIC IMPLANT Ø 3,75 - ALPHA BIO Ø 3,75 - and others



108AVB

Castable abutment (non rotating) with titanium screw for **Screw Vent** implant diam. **3,75 mm**.
Abutment with hex (slightly conical) special for bar connections.

108CV

Long castable abutment (non rotating) with titanium screw for implant. **Screw Vent diam. 3,75 mm**.

108AVB45

Castable abutment (non rotating) with titanium screw for implant. **Screw Vent diam. 4,5 mm**.



FMC008

Long castable abutment (non rotating) for **Screw Vent** implant diam. **3,75 mm**.

FMC015

Castable abutment (non rotating) for **Screw Vent** implant diam. **4,5 mm**.

FMC007

Castable abutment (non rotating) for **Screw Vent** implant diam. **3,75 mm**.
Abutment with hex (slightly conical) special for bar connections.



FA003

Steel analog for **Screw Vent** implant diam. **3,75 mm**



FVE002

Titanium screw for **Screw Vent** implant.



FVE001

Long titanium screw mm.15 with screwdriver cut for **Screw Vent** implant.



113CV11

Impression coping with titanium screw for **Screw Vent**. diam. **3,75 mm**.

Compatible components for FRIALIT 2 implants



108FRI34

Castable abutment (non rotating) with titanium screw for **FRIALIT 2** implant diam. **3,4 mm**

108FRI38

Castable abutment (non rotating) with titanium screw for **FRIALIT 2** implant diam. **3,8 mm**

108FRI45

Castable abutment (non rotating) with titanium screw for **FRIALIT 2** implant diam. **4,5 mm**.

108FRI55

Castable abutment (non rotating) with titanium screw for **FRIALIT 2** implant diam. **5,5 mm**.



FMC025

Long castable abutment (non rotating) for **FRIALIT 2** implant diam. **3,4 mm**.

FMC026

Long castable abutment (non rotating) for **FRIALIT 2** implant diam. **3,8 mm**.

FMC027

Long castable abutment (non rotating) for **FRIALIT 2** implant diam. **4,5 mm**.

FMC028

Long castable abutment (non rotating) for **FRIALIT 2** implant diam. **5,5 mm**.



FVE023

Titanium screw for **FRIALIT 2** implant.

Compatible components for ASTRA implants



108AOA





Castable abutment (non rotating) with titanium screw for **Astra** diam. **3,5 - 4 mm (light blue)**

108AOL

Castable abutment (non rotating) with titanium screw for **Astra** diam. **4,5 - 5 mm (Lilla)**

Compatible components for PITT EASY implants







	108PE325	Castable abutment (non rotating) with titanium screw for PITT EASY implant diam. 3,25 mm.
	108PE375	Castable abutment (non rotating) with titanium screw for PITT EASY implant diam. 3,75 mm.
	108PE4	Castable abutment (non rotating) with titanium screw for PITT EASY implant diam. 4 mm.
	113PE	Impression coping with titanium screw for PITT EASY diam. 3,25 mm. and diam. 3,75 mm.
	113PE4	Impression coping with titanium screw for PITT EASY diam. 4 mm.
	FPE001	Steel analog for PITT EASY implant diam. 3,25 mm. and 3,75 mm.
	FPE004	Steel analog for PITT EASY implant diam. 4 mm.
	FMC0072	Castable abutment (non rotating) for PITT EASY implant diam. 3,25 mm.
	FMC011	Castable abutment (non rotating) for PITT EASY implant diam. 3,75 mm.
	FMC0074	Castable abutment (non rotating) for PITT EASY implant diam. 4 mm.
	FMC014	Long castable abutment (non rotating) for PITT EASY implant diam. 4 mm.
	FVE0022	Titanium screw for PITT EASY implant.
	FVE003	Long titanium screw mm.19 with screwdriver cut for PITT EASY implant.

Compatible components for BRANEMARK implants

3i Ø 4,1 - EASYIMPLANT Ø 4,1 - ESTHETIC IMPLANT Ø 4,1 - P1H Ø 4,1 - MIS Ø 4,1 - OUT-LINK Ø 4,1 - SYNTHESIS Ø 4,1 - SUSTAIN Ø 4,1 - LEADER Ø 4,1 - ed altri.



	108BRK	Castable abutment (non rotating) with titanium screw for BRANEMARK narrow platform implant diam. 3,3 mm.
	108BRK	Castable abutment (rotating) with titanium screw for BRANEMARK regular platform implant diam. 3,75 - 4 mm.
	108BRK	Castable abutment (non rotating) with titanium screw for BRANEMARK regular platform implant diam. 3,75 - 4 mm.
	108BWP	Castable abutment (non rotating) with titanium screw for BRANEMARK wide platform implant diam. 5 - 5,5 mm.
	FMC032	Castable abutment (non rotating) for BRANEMARK narrow platform diam.3,3mm.
	FMC020	Castable abutment (non rotating) for BRANEMARK regular platform diam. 3,75 - 4 mm.
	FMC005	Castable abutment (rotating) for BRANEMARK regular platform diam. 3,75 - 4 mm.
	FMC021	Castable abutment (non rotating) for BRANEMARK wide platform diam. 5 - 5,5 mm.
	FVE026	Titanium screw for BRANEMARK narrow platform diam. 3,3 mm.
	FVE005	Titanium screw for Branemark regular platform diam. 3,75 - 4 mm
	FVE021	Titanium screw for BRANEMARK wide platform diam. 5 - 5,5 mm.
	FA005	Steel analog for BRANEMARK regular platform diam. 3,75 - 4 mm.

Compatible components for **REPLACE SELECT** implants NOBEL-BIOCARE NP Ø 3,5 - RP Ø 4,3



108RPS35

Castable abutment (non rotating) with titanium screw for **Nobel Replace Select narrow platform diam. 3,5 mm.**

108RPS43

Castable abutment (non rotating) with titanium screw for **Nobel Replace Select regular platform diam. 4,3 mm.**



FMC037

Castable abutment (non rotating) for **Nobel Replace Select narrow platform diam. 3,5 mm.**

FMC038

Castable abutment (non rotating) for **Nobel Replace Select regular platform diam. 4,3 mm.**



FVE032

Titanium screw for **Nobel Replace Select platform diam. 3,5 mm - 4,3mm**

Accessori compatibili per impianti **ITI Straumann**



108BFT

Castable abutment (rotating) without octa with titanium screw for **ITI Straumann regular platform**

108BFTNR

Castable abutment (non rotating) with titanium screw for **ITI Straumann regular platform**



113BFT

Impression coping with titanium screw without octa for **ITI Straumann implant.**



FA006

Steel analog for **ITI Straumann (non rotating)** with octa.

FA004

Steel analog for **ITI Straumann (rotating)** without octa.



FMC006

Castable abutment (rotating) without octa for **ITI Straumann.**



FVE004

Titanium screw for **ITI Straumann.**

Compatible components for **THOMMEN SPI** line implants



108SPI4

Castable abutment (non rotating) with titanium screw for **SPI platform diam. 4 mm.**

108SPI45

Castable abutment (non rotating) with titanium screw for **SPI platform diam. 4,5 mm**

Tapered hex tool



760CBR

HEX TOOL FOR PROSTHETIC SCREWS (HEX MM 1,3)

Universal "anti-Unscrewing" systems



Applicable to different screw, with a size not lower than Ø 1,8 mm.

TE



▶ Elastic Dowel



▶ Differents applications